

Fisher® LNG Liquefaction Solutions

Proven control valve technology for your LNG facility





Let Emerson Help Solve Your Toughest Challenge

Your plant must produce LNG at an efficient and constant rate. If you don't meet your production obligations, you not only lose revenue, you may be subject to contractual penalties. This means the control valves in your facility must operate reliably, the way you need them to in your most critical applications 24/7—with no surprises—to help your facility operate at its nameplate capacity.

Please use this brochure as a guide to discovering the breadth of Fisher® control valve solutions for the most critical applications in your LNG facility.



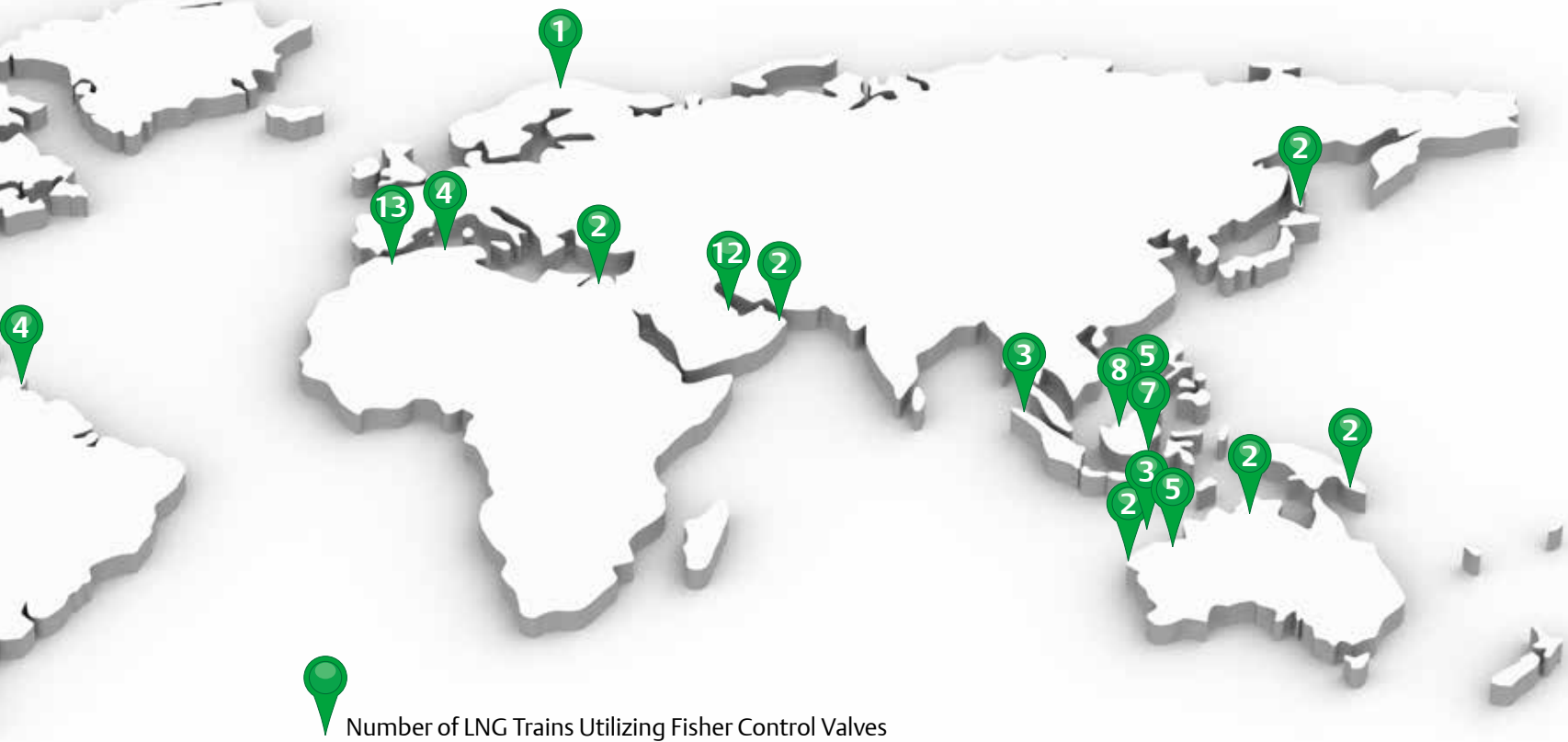

A History of Proven Results

From the first LNG facilities built in Alaska, Brunei, and Algeria in the 1960s and 1970s, to the most advanced facilities currently under development, Fisher valves can be found in the majority of liquefaction facilities in the world. In fact, more than 70 percent of existing LNG production flows through Fisher valves.

More than 40 years of experience in LNG has allowed Emerson to develop reliable, field-proven Fisher solutions for your most critical applications. By partnering with Emerson, you'll be able to leverage our wealth of LNG experience and utilize proven Fisher technologies to help you ensure the reliability of your plant. From the feed gas pipeline to the export jetty, the Fisher brand is the name to trust in LNG.

Typical Mixed Refrigerant Liquefaction Process

The majority of existing LNG plants utilize a variation of the propane pre-cooled, mixed refrigerant liquefaction process. This process utilizes propane refrigerant to chill the feed gas and a mixed refrigerant to achieve liquefaction and sub-cooling. Most recent variations of the process produce 4.0 – 5.0 megatons per annum (mtpa) of output per train. Greenfield plants will commonly consist of one to three trains with room for additional trains depending on long term feed gas supply. Larger-scale variations of the process utilize a third refrigerant loop of nitrogen to achieve sub-cooling, and have been used to achieve nearly 8.0 mtpa of output per train. This “mega train” configuration is featured in the process diagram below.



LEGEND

- 1** Inlet Feed Gas Control Valve
- 2** Rich Amine Letdown Control Valve
- 3** Amine Pump Recycle Control Valve
- 4** Gas-to-Flare Control Valve
- 5** Compressor Antisurge Control Valve
- 6** Joule-Thomson / Expander Bypass Control Valve

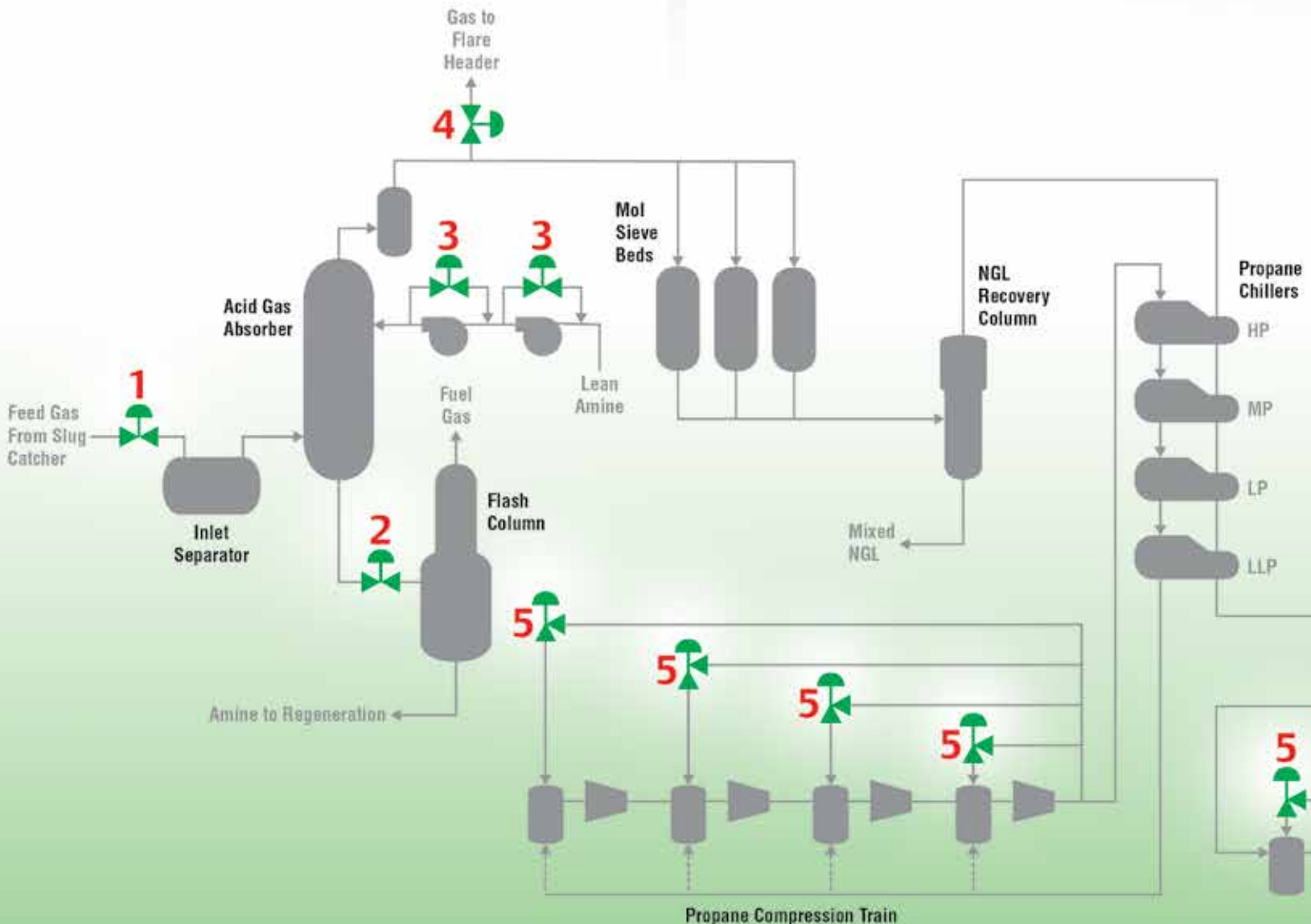

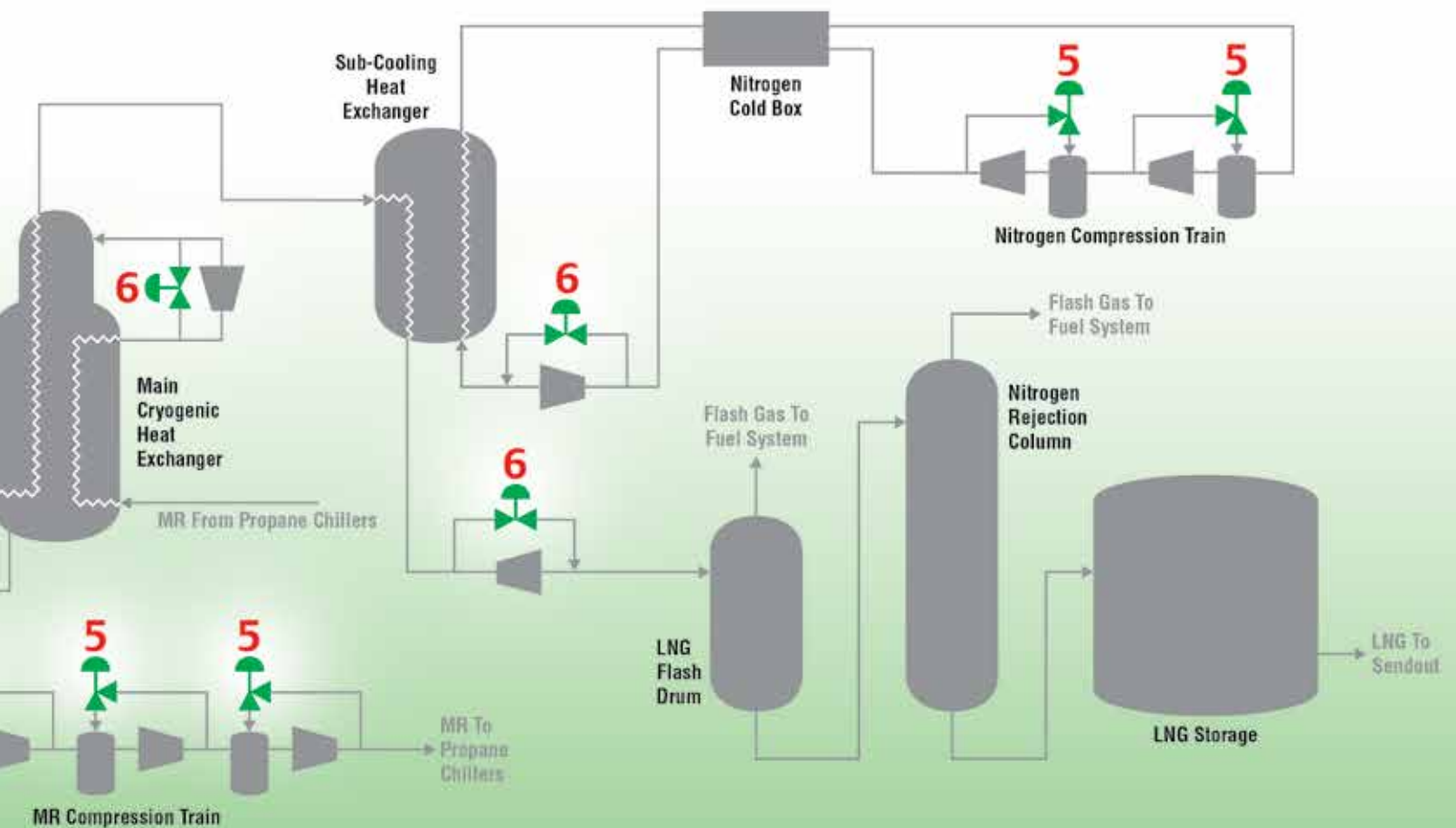

Typical Cascade Liquefaction Process

A cascade liquefaction process typically utilizes three pure-component refrigerant loops: propane, ethylene, and methane. Feed gas is pre-cooled as it passes through the propane chiller before undergoing liquefaction and sub-cooling through ethylene and methane cold boxes. Most recent variations of the process produce 4.5 – 5.2 mtpa per train. Greenfield plants will commonly consist of one to three trains with room for additional trains depending on long term feed gas supply.

LEGEND

- 1** Inlet Feed Gas Control Valve
- 2** Rich Amine Letdown Control Valve
- 3** Amine Pump Recycle Control Valve
- 4** Gas-to-Flare Control Valve
- 5** Compressor Antisurge Control Valve
- 6** Joule-Thomson / Expander Bypass Control Valve

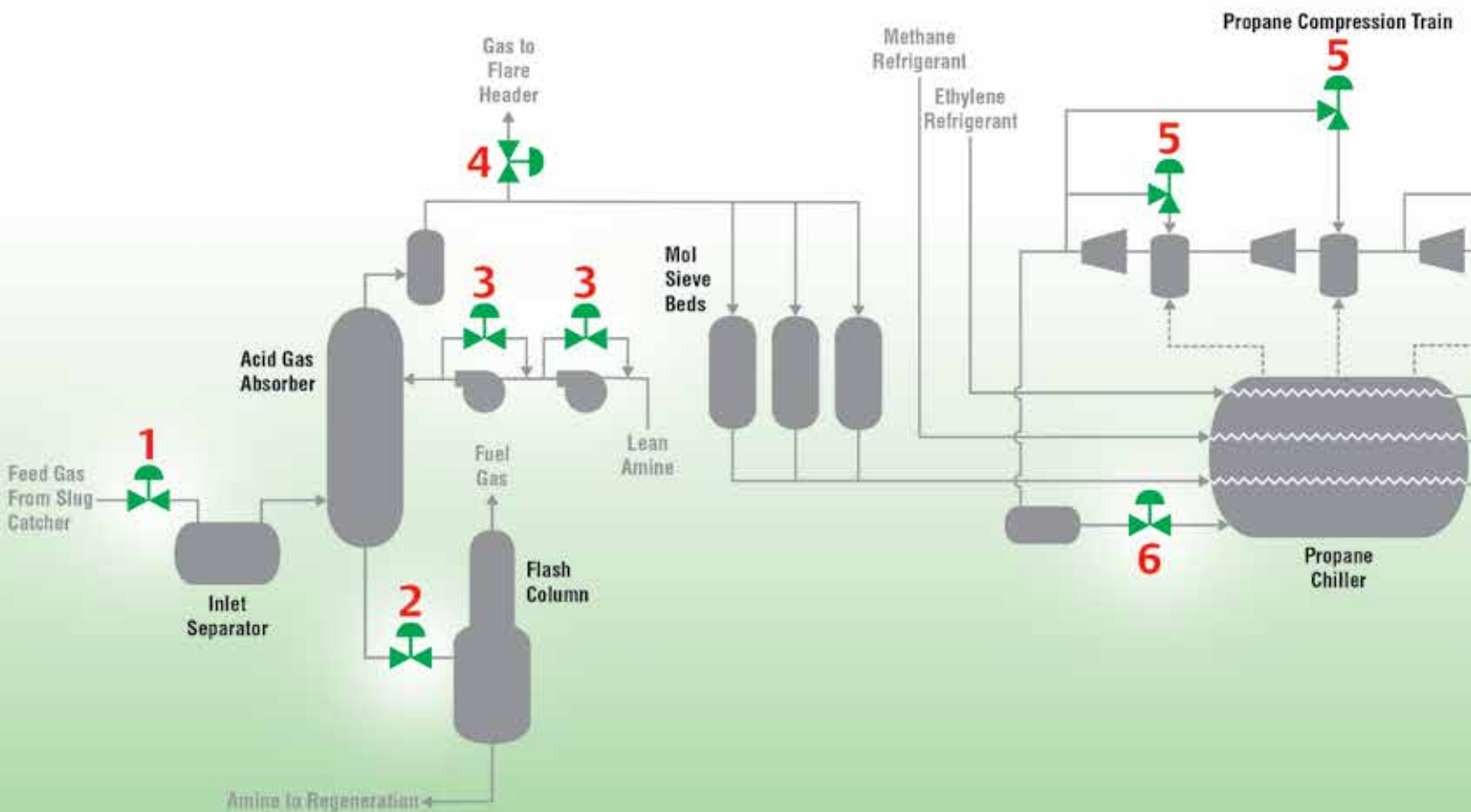

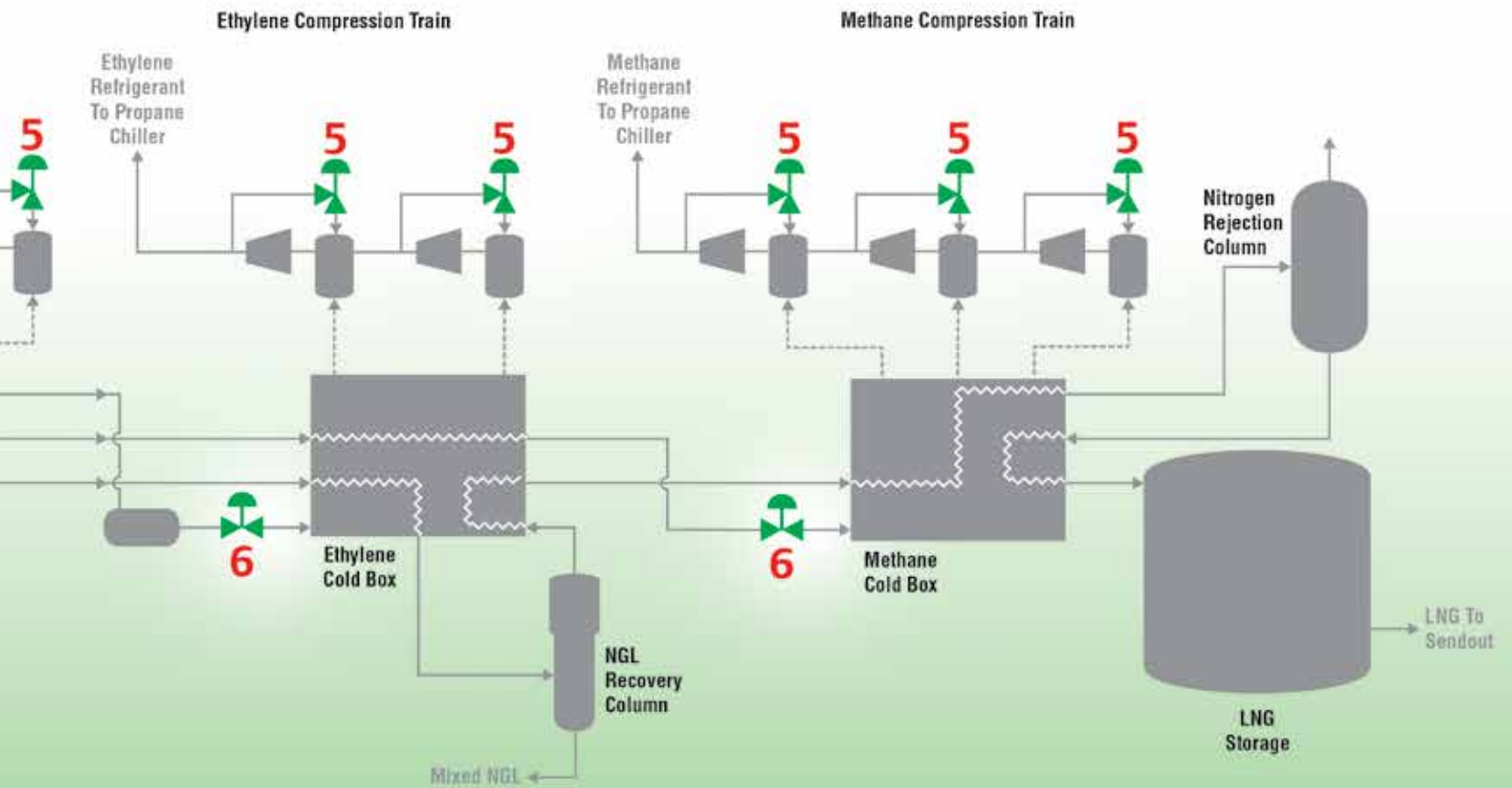

Inlet Feed Gas Control Valve

The inlet receiving facilities serve a number of functions that are critical to the smooth operation of the entire facility. The receiving facilities knock out any liquids present in the feed gas, reduce the pressure from the gas pipeline, and throttle the flow of gas into the downstream processing units. Stable and reliable operation of the receiving facilities lays the foundation for the profitable operation of the entire facility.

The location of the inlet feed gas valves will depend on the extent of gas treatment located onsite. If the facility includes a gas treatment unit and receives raw feed gas from production, the inlet valve is located upstream of the acid gas removal unit. If the liquefaction plant receives sales-quality gas from the local grid, which requires minimal treatment, the valve will be located upstream of the liquefaction trains.

At some facilities, a single large valve is used in this application. At others, a number of smaller valves in parallel will be used to control the flow of the feed gas. Reliability is the foremost requirement for the inlet feed valves. Unexpected maintenance or surprise failures have the potential to bring down LNG production, which can incur significant contractual penalties. In addition, these valves must also be able to provide precise, stable control through a wide range of gas flow rates from startup and commissioning through full rated output of the plant. These valves must operate with minimal variability to ensure stable and predictable performance of all process units downstream. Depending on the operating pressure of the pipeline, these valves can also experience a significant pressure drop. This can cause the potential for damaging noise and vibration if not addressed properly.

A Case-In-Point

The operator of a multi-train liquefaction facility in Australia needed absolute assurance that their critical feed gas inlet valves would provide the proper rate of flow into the facility. Too much flow could overwhelm the plant's pressure relief capacity, requiring expensive modifications. Too little flow could restrict the overall capacity of the entire multi-billion dollar facility.

Emerson engineers developed custom Fisher Whisper Trim designs for these NPS 12 ANSI 1500 valves tailored specifically to the noise and capacity requirements of this critical application. To provide the ultimate assurance that these custom valves would meet the exacting application requirements, the valves were flow tested at the Emerson Innovation Center to demonstrate the maximum capacity.

Flow testing confirmed the actual capacity of the valves to be within 3% of the design values, well within the plant operator's specification.

PREDICTIVE MAINTENANCE

Online, in-service FIELDVUE™ Performance Diagnostics enable predictive maintenance programs for critical valves such as the inlet feed gas valves, helping to achieve greater reliability.

STABLE CONTROL

The precise throttling capability of the FIELDVUE DVC6200 instrument combined with Fisher low-friction packing technology helps to ensure responsive and stable control of the plant's inlet feed gas to reduce variability downstream.

CORROSION RESISTANCE

A full range of alloy materials are available to mitigate the corrosive effects of H₂S and other contaminants present in the feed gas.

THROUGHPUT FLEXIBILITY

Fully customizable valve flow characteristics provide broad rangeability that enables precise throttling throughout the full range of feed gas demand.

NOISE REDUCTION

Advanced noise attenuation technology lowers noise levels up to 40 dB to meet regulatory noise limits.

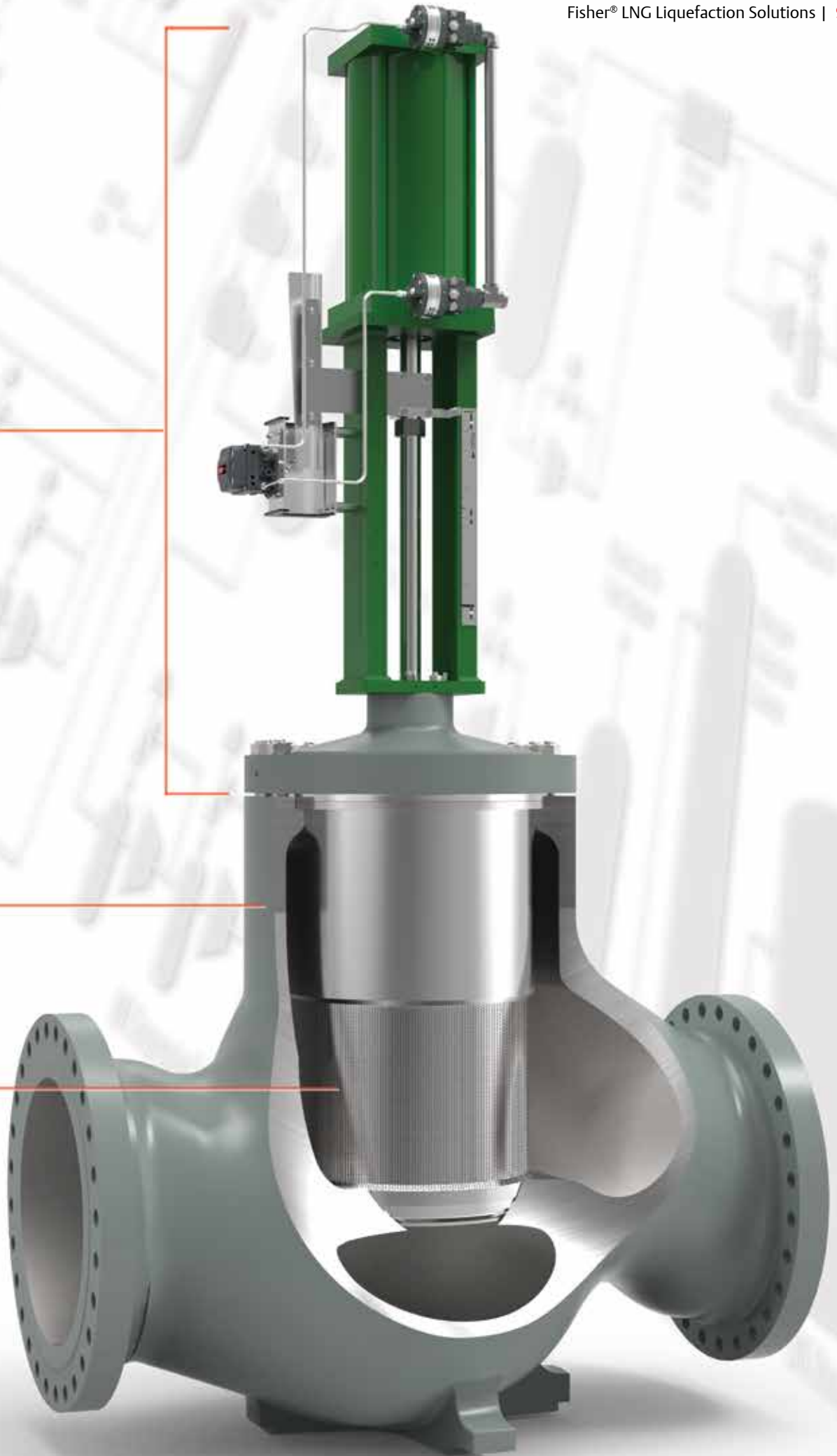

Fisher NPS 30 ET Control Valve with FIELDVUE DVC6200 Digital Valve Controller

Rich Amine Letdown Control Valve

In facilities that receive raw gas from production, the acid gas removal unit plays a critical role in the process by stripping CO₂ and/or H₂S contaminants from the feed gas. The presence of these acid gases in excess of specified limits can cause significant issues in downstream units. The presence of H₂S can cause serious corrosion issues and CO₂ can cause freeze-up in the liquefaction train. As a result, specifications for feed gas are very stringent and typically require max acid gas content of 50 parts per million (ppm) CO₂ and 2 ppm H₂S.

As feed gas enters the contactor at the bottom and flows upward, lean amine solution flowing countercurrent gradually strips the gas of impurities. The rich amine letdown valve serves two purposes. First, it regulates the level of rich amine solution that accumulates in the bottom of the contactor vessel. Second, it facilitates a pressure drop into the downstream flash tank, which liberates a portion of the acid gases entrained in the solution. If not addressed properly through detailed valve sizing and selection, this outgassing of the entrained gases can cause significant vibration and damage to the valve.

Fisher control valve engineers have decades of experience with the most severe outgassing applications and have learned that no two amine letdown applications are exactly the same. Proprietary outgassing modeling ensures that the valve type selected is tailored specifically to each application and sized appropriately to mitigate the gas coming out of the solution.

In some facilities, solids or pipe scale will accumulate in the bottom of the amine contactor. Emerson offers Fisher dirty service solutions to prevent plugging while also addressing the outgassing phenomenon.

PREDICTIVE MAINTENANCE

Online, in-service FIELDVUE Performance Diagnostics enable predictive maintenance programs for critical valves such as the rich amine letdown valve, helping to achieve greater reliability.

EXTENDED SERVICE LIFE

Properly selected valve and trim designs are proven to mitigate the potentially damaging effects of outgassing.

CORROSION RESISTANCE

Full range of alloy materials available to mitigate the corrosive effects of H₂S and other contaminants.

PROCESS INSIGHT

In-depth understanding of the outgassing phenomenon with tailored valve solutions based on severity. No one-size-fits-all trim solution.

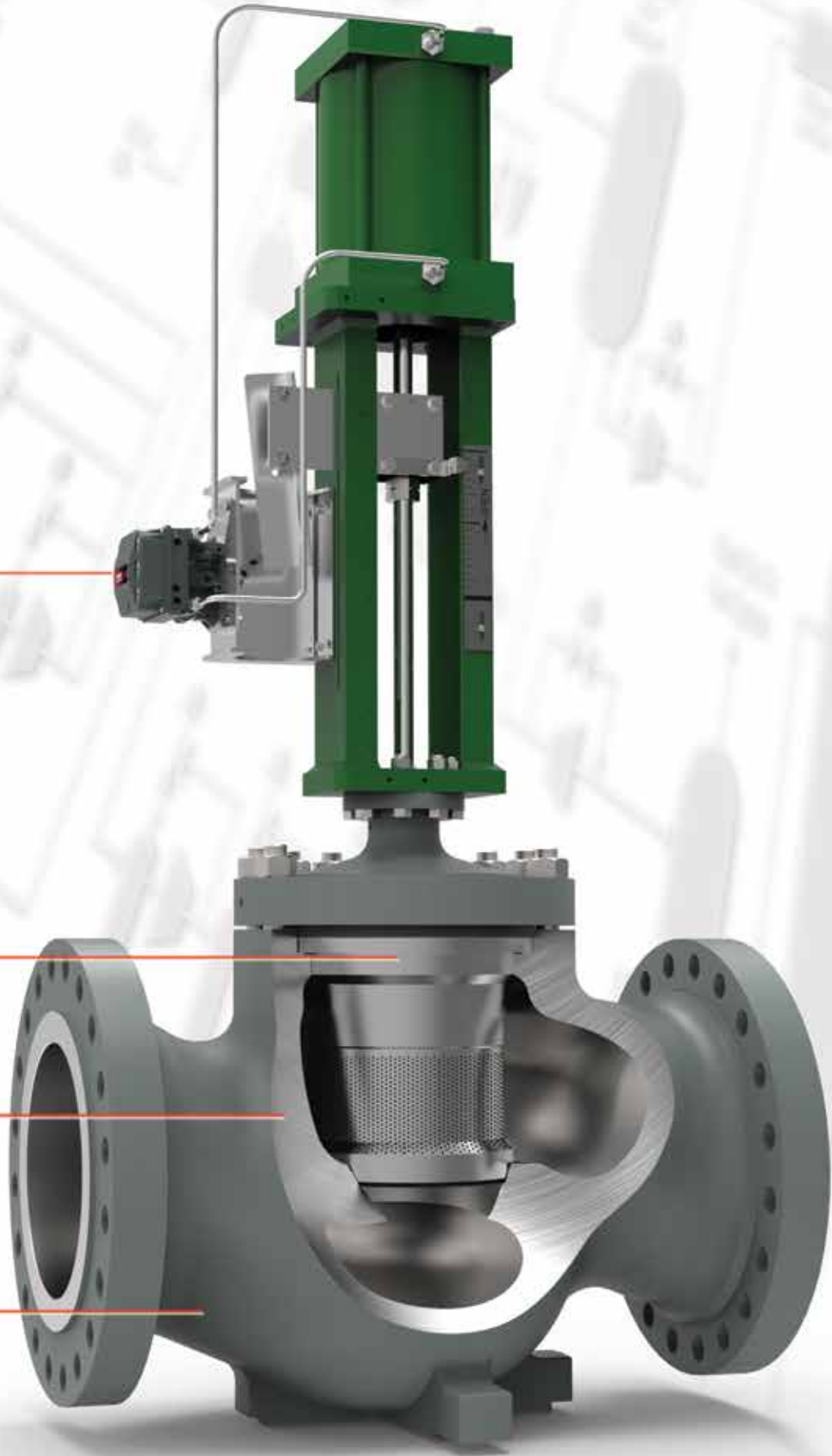

Fisher NPS 16 ET Control Valve with FIELDVUE DVC6200 Digital Valve Controller

Amine Pump Recycle Control Valve

Maintaining the proper flow of lean amine within the acid gas removal unit is necessary to ensure sufficient removal of CO₂ and H₂S from the feed gas stream. The lean amine pump ensures the stable flow of lean amine to the contactor.

The amine pump recycle valve is most commonly used to facilitate startup and commissioning as the acid gas removal unit is brought up to capacity. This valve controls the pump discharge flow that is routed back around to the suction side of the pump. When needed, the recycle flow boosts the suction pressure to keep it above the vapor pressure of the amine. As a result, the amine pump recycle valve must be very responsive in order to protect the pump from cavitation damage.

Due to the high pressure differential from discharge back to suction, the valve trim must be capable of mitigating the potentially damaging effects of cavitation as it recycles flow. Any unplanned maintenance on these valves due to cavitation damage can bring the amine pumps down and reduce plant throughput.

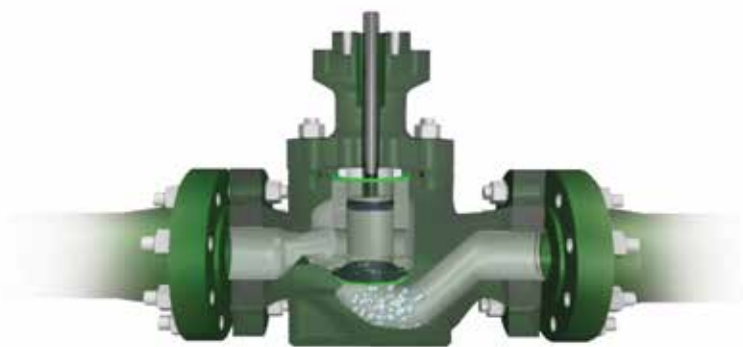

To learn more about how Fisher anti-cavitation technologies can help prevent damage to your valves, view an animation video at www.FisherSevereService.com



Scan this code to discover the broad range of Fisher anti-cavitation technology solutions for both clean and dirty service applications.

ASSET PROTECTION

Advanced actuation technology enables highly responsive throttling of the recycle flow to maintain sufficient suction pressure and helps to prevent cavitation damage to the pump.

PREDICTIVE MAINTENANCE

Online, in-service FIELDVUE Performance Diagnostics enable predictive maintenance programs for critical valves such as the amine pump recycle valve, helping to achieve greater reliability.

REDUCED MAINTENANCE

Proven anti-cavitation technology helps to prevent damage to internal valve components to reduce maintenance needs and unplanned downtime.

THROUGHPUT FLEXIBILITY

Fully customizable valve flow characteristic allows for precise throttling through the broad range of flow rates required during commissioning and plant operation.

IMPROVED EFFICIENCY

Tight shutoff capability to meet ANSI Class V or VI requirements and prevent unwanted recycle flow when the valve is closed to help optimize pump efficiency.



Fisher NPS 8 ET Control Valve with FIELDVUE DVC6200 Digital Valve Controller

Gas-to-Flare Control Valve

All gas processing facilities have a flare system to safeguard against overpressure of critical assets within the plant and dispose of any waste gas. Failure of the flare system to successfully relieve pressure from the process can lead to unexpected downtime or damage to costly pressure-retaining equipment.

Gas-to-flare valves are installed at numerous locations throughout the gas treatment and liquefaction units to control the flow of feed gas or refrigerant to the flare stack for disposal. They are primarily used during plant startup, shutdown, or short-duration upset conditions. During these periods, flare valves will experience significant pressure differentials and high flow rates. If not addressed properly, these conditions can lead to excessive noise levels and even damaging vibration.

Emerson utilizes the industry standard for aerodynamic noise modeling and prediction in control valves, IEC 60534-8-3. This standard models two independent sources of noise -- the valve trim and the valve body outlet. In applications with moderate pressure drop, noise attenuating trim is commonly sufficient to maintain overall noise levels at acceptable levels. However, in high pressure drop applications such as gas-to-flare, the valve body outlet noise will commonly overcome the trim noise as the dominant source. To account for this, Emerson's engineers use the latest IEC noise prediction model to account for both independent sources of noise when developing custom valve solutions for your high pressure drop applications. This comprehensive approach incorporates noise-attenuating technology to reduce trim noise and a properly-sized valve body outlet to maintain acceptable noise levels at the outlet.

During the normal operation of the plant, gas-to-flare valves will remain closed. Because of this, it is important that these valves maintain tight, long-term shutoff in order to prevent loss of valuable product to the flare stack.

A Case-In-Point

A gas processing plant in Saudi Arabia experienced cracking of a NPS 54 acid flare header made of Inconel. Two Emerson engineers studied the process conditions and concluded that the existing valves were contributing to excessive vibration and noise. Despite the use of noise-attenuating trim, the valves

had not been properly sized to account for valve body outlet noise, which resulted in valve outlet velocities close to sonic – 0.7 mach.

After several visits to this remote site, Emerson recommended a larger replacement valve with Fisher WhisperFlo™ trim that would meet all of the process conditions.

Existing valves were replaced by two NPS 16 Fisher ET control valves with WhisperFlo Level Z trim. The valves lowered the velocity of the outlet to 0.3 mach, which significantly reduced the noise at the valve and the vibration affecting the downstream piping.

QUICK RESPONSE

Fisher actuation technologies enable rapid response to meet your demanding stroke requirements and provide dependable response to planned or unexpected flaring.

PREDICTIVE MAINTENANCE

Online, in-service FIELDVUE Performance Diagnostics enable predictive maintenance programs for critical valves such as the gas-to-flare valve, helping to achieve greater reliability.

CORROSION RESISTANCE

A full range of alloy materials are available to mitigate the corrosive effects of H₂S and other contaminants present in the flare gas.

COMPREHENSIVE NOISE MANAGEMENT

Noise modeling and prediction per IEC 60534-8-3 allows Emerson to address both trim and valve body outlet noise upfront to prevent surprises for you down the road.

PRODUCT LOSS PREVENTION

Tight shutoff capability to meet ANSI Class V or VI requirements and prevent loss of valuable product to the flare stack.



Scan this code or visit www.FisherSevereService.com to learn about the science of noise attenuation in control valves and our history of solving noise issues in facilities just like yours.

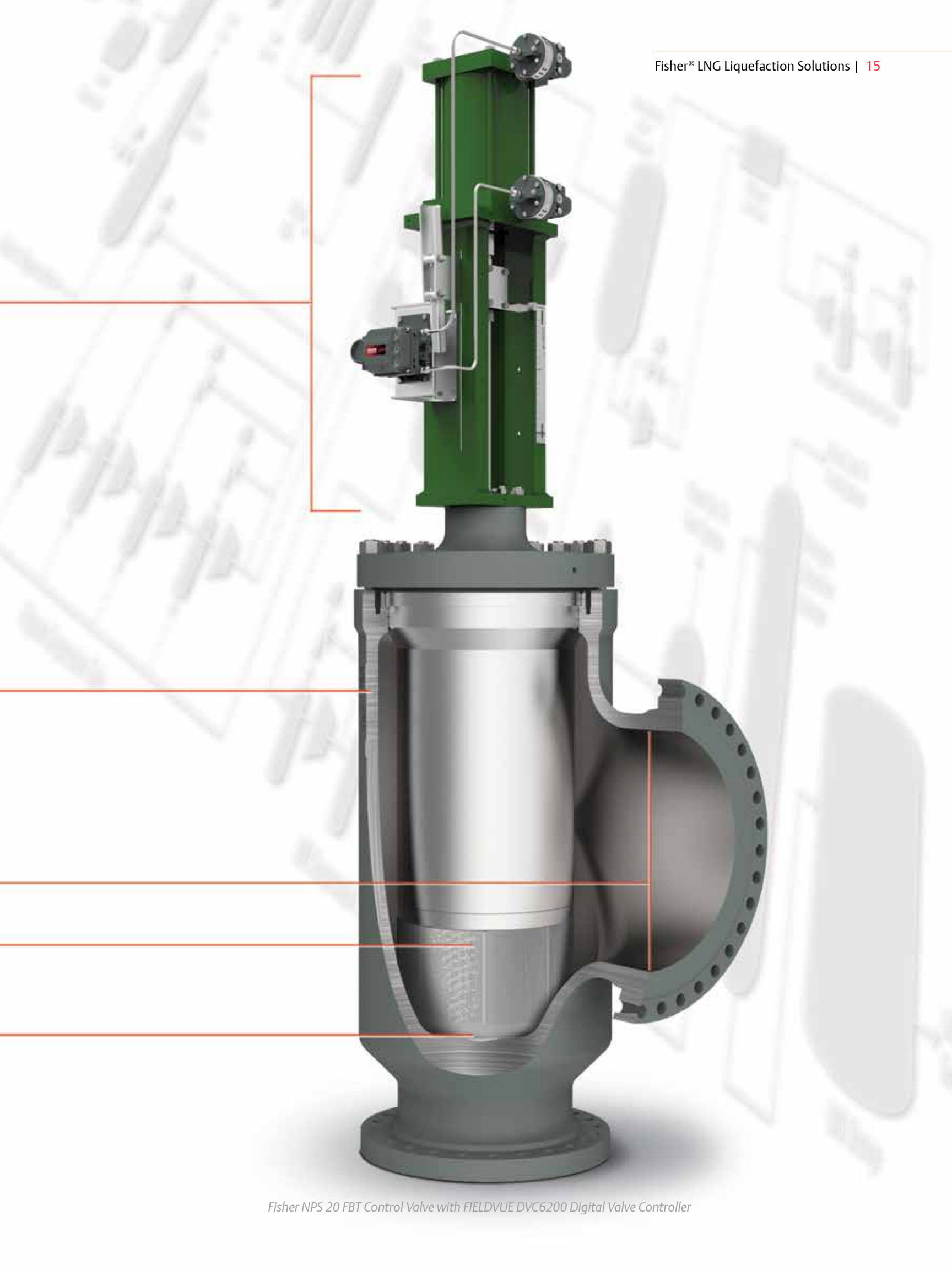

Fisher NPS 20 FBT Control Valve with FIELDVUE DVC6200 Digital Valve Controller

Compressor Antisurge Control Valve

The efficiency and availability of a plant's compressors both have a direct impact on the profitability of the facility. Unexpected downtime of any of the plant's refrigerant loops will lead to reduced LNG production and the potential for hefty contractual penalties. Compressors also represent some of the most valuable pieces of equipment within an LNG facility. Not only will damage to these assets cause unexpected production downtime, it can also lead to very costly repairs.

Antisurge valves provide recycle flow to each stage of the multi-stage compression trains that are common to liquefaction processes. During startup and commissioning, the valve provides throttling control to recycle a portion of the discharge flow as the compressor is brought up to capacity. During the normal operation of the plant, the antisurge valve will remain closed or slightly open to allow for a small portion of the discharge to be recycled. When closed, it is important that the valve provides tight shutoff to prevent unwanted recycle flow.

The primary purpose of the antisurge valves is to protect the most critical and expensive pieces of equipment in the plant, the compressors. During a surge event, the valve must open in one to two seconds to recycle the discharge flow back around to the suction side of the compressor. Failure of the valve to react quickly to the antisurge controller can result in severe damage to the impellers of the compressor from the reversed flow of a surge event.

A Case-In-Point

An LNG facility in Brunei needed to replace all of its existing propane and mixed refrigerant compressor antisurge valves. After seeing a demonstration of the Fisher optimized antisurge valve, the plant turned to Emerson who has proven its

ability to understand and meet stringent valve performance criteria.

The 25 existing valves were replaced by NPS 12 through NPS 30 Fisher optimized antisurge valves.

- *The valves open in less than two seconds, as well as meet stringent closed-loop control criteria.*
- *The measured linearity is less than 0.75%, and the valves have minimal overshoot in the open and closed directions.*
- *It often requires about 12 hours to tune a non-Fisher antisurge valve. With its fewer accessories and diagnostic capabilities, tuning time for a Fisher optimized antisurge valve takes only minutes.*

All this added up to an antisurge valve solution that helped to protect compressors and increase process efficiency.

ASSET PROTECTION

The fast stroking capability of the Fisher optimized antisurge valve protects your compressor from surge events by quickly recycling flow back to the suction drum.

ACCURATE CONTROL

The highly accurate, responsive throttling control allows confident operation closer to your compressor's surge limit line, helping to improve its operating efficiency.

PROVEN RELIABLE

The simplified and rugged actuation system incorporates the non-contact valve position feedback of the FIELDVUE DVC6200 instrument to enhance long term reliability.

PREDICTIVE MAINTENANCE

Online, in-service FIELDVUE Performance Diagnostics enable predictive maintenance programs for critical valves such as the compressor antisurge valves, helping to achieve greater reliability.

QUICK STARTUP

Simple, user-friendly tuning interface can significantly reduce startup and commissioning time.



Scan this code to learn more about the Fisher optimized antisurge solution designed specifically for antisurge applications.

COMPREHENSIVE NOISE MANAGEMENT

Noise modeling and prediction per IEC 60534-8-3 allows Emerson to address both trim and valve body outlet noise upfront to prevent surprises for you down the road.

TAILORED FLOW CHARACTERISTIC

Fully customizable valve flow characteristic helps to provide precise control throughout the full range of startup conditions in addition to full-open surge capacity.

TIGHT SHUTOFF CAPABILITY

Tight shutoff capability to meet ANSI Class V or VI shutoff requirements and prevent unwanted recycle flow past the valve to optimize compressor efficiency.

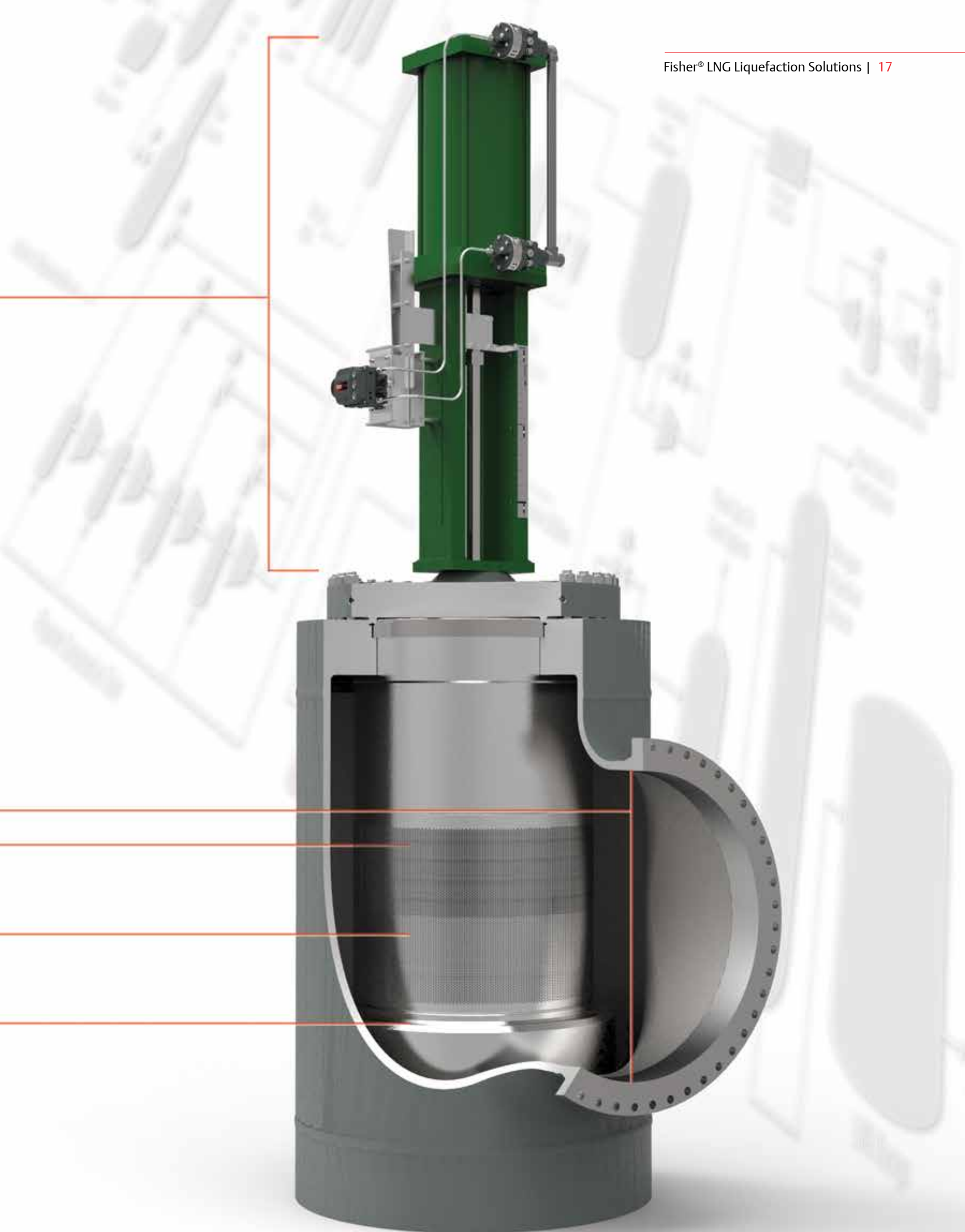

Fisher NPS 42 FBT Control Valve with Optimized Digital Valve Actuation

Joule-Thomson/Expander Bypass Control Valve

The Joule-Thomson effect is leveraged throughout all of the primary liquefaction processes to achieve cooling of the feed gas or the refrigerant streams. It is used to achieve cooling of liquids, gases, or multi-phase fluids. Traditionally, this effect has been facilitated by a control valve that reduces the pressure of the fluid significantly and induces the desired cooling. Because of the elevated pressure drop, the valve can experience excessive noise levels if not addressed properly. It also experiences very low process temperatures and must be capable of precise throttling down to full cryogenic temperatures.

In some facilities, expanders are utilized to facilitate Joule-Thomson cooling while also recovering energy from the fluid to improve overall process efficiency. Expanders are used in both gas and liquid applications (commonly referred to as hydraulic turbines in liquid applications). Regardless of the fluid, expander bypass valves are installed in parallel with expanders to ensure process availability. In instances when the expander is required to go offline, the bypass valve is opened to facilitate Joule-Thomson cooling of the process stream and allow the unit to continue operating in the absence of the expander. The bypass valve must be highly responsive and reliable to ensure process availability. It is also commonly subjected to a large pressure differential, which creates the potential for significant noise levels in gas applications and flashing in liquid applications.

STABLE CONTROL

Precise throttling control of the FIELDVUE DVC6200 instrument to maintain the stable flow of refrigerant to chillers and cold boxes.

REDUCED MAINTENANCE

Specially-selected balance seal materials enhance cycle life at cryogenic temperatures to reduce maintenance needs.

NOISE REDUCTION

Advanced noise attenuation technology lowers noise levels up to 40 decibels to meet regulatory noise limits.

IMPROVED EFFICIENCY

Unwanted bypass flow around the expander during normal operation is addressed via advanced cryogenic capabilities. Fisher balance seal and seat ring technologies provide cryogenic shutoff in compliance with demanding cryogenic test standards such as BS 6364.

EXPANDED VALVE OUTLET

Expanded-outlet valve body design to allow for flashing in liquid applications and the downstream expansion of lighter hydrocarbon constituents.



Fisher NPS 16 ET Control Valve with FIELDVUE DVC6200 Digital Valve Controller

You're Never Alone

The way you manage key production assets like control valves directly affects your plant's efficiency, reliability, and profitability. Emerson Process Management's Fisher Services provides trusted expertise for control valve maintenance and repair.

Whether you're starting or commissioning a process, scheduling diagnostics and repair, or planning a turnaround with upgrades to optimize and extend your plant's lifecycle, our network of owned and authorized service centers around the world provide effective maintenance through a network of experienced, highly skilled technicians when and where you need them.

To help you maintain your plant's efficiency and reliability, Fisher Services uses only certified OEM parts and assemblies sourced through local inventories, regional parts distribution centers, and Quick Ship facilities to deliver unmatched response to customer needs.



Contact your local sales office to get in touch with the Service Center nearest you. To learn more, scan the QR code or visit www.Fisher.com.



Our extensive network of Service Center locations spans every continent. We're there for you day or night, when and where you need us, 24/7/365. To learn more, scan the QR code or visit www.Fisher.com/LifecycleServices

DO YOU NEED TO...



Optimization

- Increase uptime and throughput
- Improve maintenance practices
- Adapt to change

Technology Upgrade

- Comply with environmental, safety, and health regulations
- Minimize variability
- Manage process changes

Startup and Commission

- Stay on schedule and within budget
- Obtain on-site experience
- Identify installation issues

Operate and Maintain

- Minimize unplanned events
- Adapt to process changes and upsets
- Access local parts, service, and expertise

Turnaround/Outage

- Stay within budget and on schedule
- Ensure consistent planning and communications
- Supplement in-house expertise

Plant Lifecycle Events and Demands

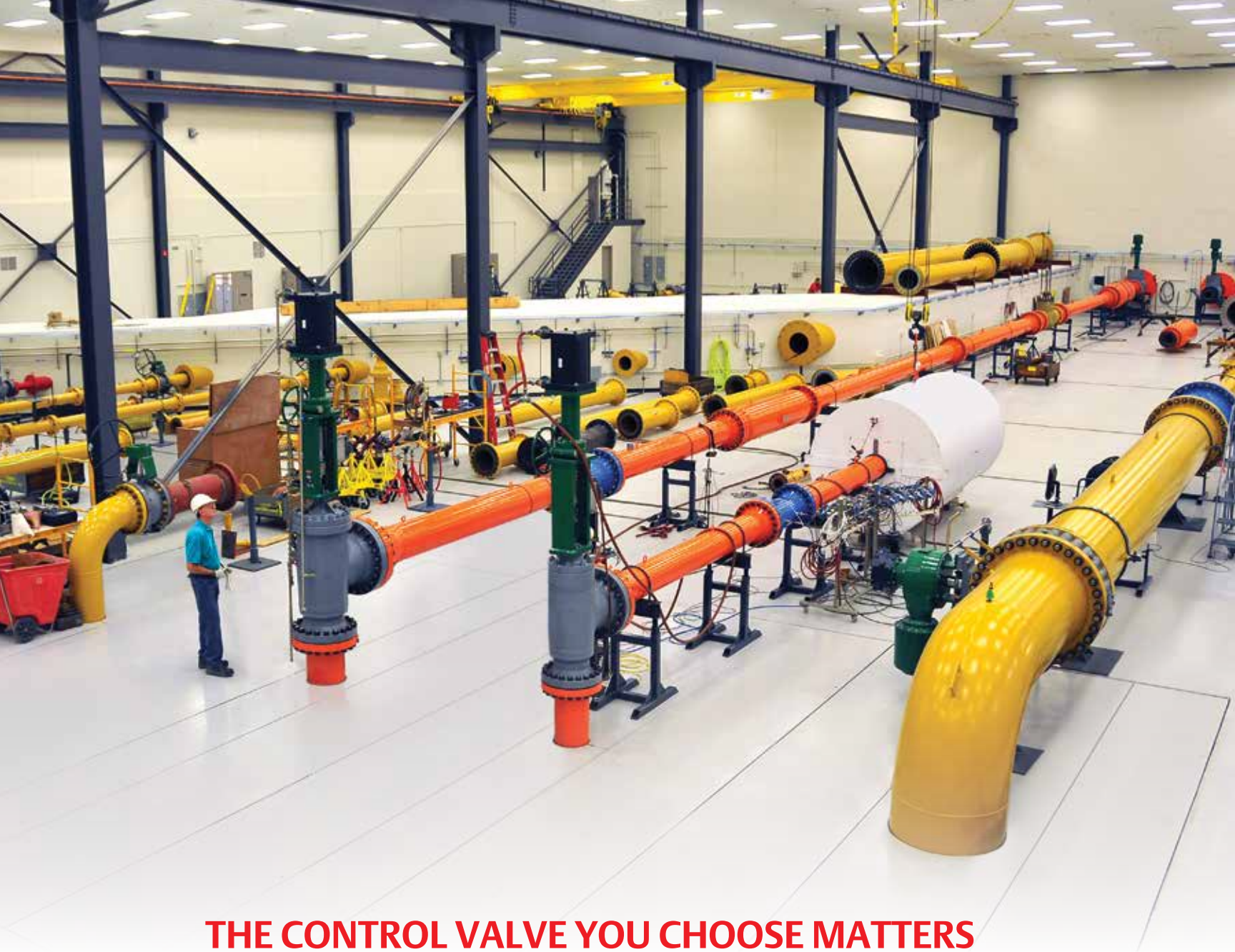

THE CONTROL VALVE YOU CHOOSE MATTERS WHEN YOU HAVE TO ACHIEVE EFFICIENT, PRODUCTIVE, AND RELIABLE PLANT OPERATION.

When you buy Fisher control valves, you get the application expertise that comes from more than forty years of experience in the LNG industry. Plus you benefit from millions of dollars of research invested in reliability-centric testing of Fisher control valve technologies.

Fisher product specifications are, in many cases, more stringent than the industry accepted standards set by regulatory agencies. Our attention to and evaluation of product quality is necessary to bring you Fisher technologies of the highest reliability and performance.

Using Fisher technology can help you achieve efficient, productive, and reliable plant operation. Want to see for yourself? Visit the Emerson Innovation Center for Fisher Technology in Marshalltown, Iowa, USA. To schedule a visit, please contact your local Emerson sales office.

Fisher technology development capabilities extend worldwide with engineers and labs in North America, Europe, and Asia.



THRIVING IN EXTREME TEMPERATURES



Whether driven by process temperatures or climate extremes, control valves need to operate as specified. Fisher control valves in LNG applications are commonly tested at cryogenic temperatures of -196°C (-321°F) in numerous Fisher sites around the world.

TROUBLESHOOTING CONTROL VALVES



While control valves are on-line and in service, Fisher digital valve controllers can detect, capture, and trend more than 200 fault conditions and provide recommended actions to prevent unexpected downtime.

HIGH CYCLE TESTING



Many of Emerson's standard Fisher products are used in extremely high-cycle applications, and must be tested to more than one million cycles. Those same standard products are used in your LNG plant to enhance reliability.

WITHSTANDING VIBRATION



Fisher control valves are designed and tested for robustness in vibration applications. They are subjected to additional testing for millions of cycles at their resonant (worst case) frequency to enhance performance in your facility.

REDUCING PROCESS VARIABILITY



Fisher control valve assemblies are subjected to on-line, dynamic performance testing to evaluate their ability to reduce your process variability. These tests replicate how control valves are used in your plant.

QUIETING NOISE



Supported with a 4,738 m² (51,000 ft²) facility and a unique 2,415 m² (26,000 ft²) sound chamber, Emerson can quantify noise from valves, piping, and vents. This capability provides insight to ensure highly accurate noise prediction and helps you comply with regulatory requirements.

If you found this brochure valuable, may we also recommend the following literature:



“Fisher® Optimized Antisurge Control Valves Brochure”

Document Number: D351146X012
www.EmersonProcess.com/Fisher/Documentation



“FIELDVUE™ DVC6200 Series Digital Valve Controllers Brochure”

Document Number: D351908X012
www.EmersonProcess.com/Fisher/Documentation



“Fisher Cavitation-Control Technologies Brochure”

Document Number: D351912X012
www.EmersonProcess.com/Fisher/Documentation

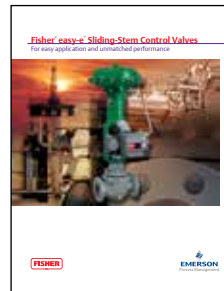

“Fisher® easy-e™ Sliding-Stem Control Valves Brochure”

Document Number: D350365X012
www.EmersonProcess.com/Fisher/Documentation



“The Silent Treatment Brochure”

Document Number: D351989X012
www.EmersonProcess.com/Fisher/Documentation



“Emerson Innovation Center Brochure”

Document Number: D351843X012
www.EmersonProcess.com/Fisher/Documentation



 <http://www.Facebook.com/FisherValves>

 <http://www.Twitter.com/FisherValves>

 <http://www.YouTube.com/user/FisherControlValve>

 <http://www.Linkedin.com/groups/Fisher-3941826>

To find the Fisher sales contact in your area, scan the QR code.



© 2013 Fisher Controls International LLC. All rights reserved.

Fisher, FIELDVUE, WhisperFlo, and Whisper Trim are marks owned by one of the companies in the Emerson Process Management business unit of Emerson Electric Co. Emerson Process Management, Emerson, and the Emerson logo are trademarks and service marks of Emerson Electric Co. All other marks are the property of their respective owners.

The contents of this publication are presented for informational purposes only, and while every effort has been made to ensure their accuracy, nothing herein is to be construed as a warranty or guarantee, express or implied, regarding the products or services described herein or their use, performance, merchantability or fitness for a particular purpose. Individual results may vary. All sales are governed by our terms and conditions, which are available upon request. We reserve the right to modify or improve the designs or specifications of our products at any time without notice. Responsibility for proper selection, use and maintenance of any product or service remains solely with the purchaser and end user.

Emerson Process Management
 Marshalltown, Iowa 50158 USA
 Sorocaba, 18087 Brazil
 Chatham, Kent ME4 4QZ UK
 Dubai, United Arab Emirates
 Singapore 128461 Singapore
www.Fisher.com

