



VAREC 180 SERIES PRESSURE REGULATORS

Double port regulators with a variety of model options for upstream and downstream pressure control



FEATURES

- Large diaphragm and a unique 'double port' design achieve a sensitivity of less than 5%.
- Set pressure controlled by a weighted lever for settings below 1" (25 mm) WC; combination weighted lever and spring for settings up to 20" (50 mm) WC.
- Double port design adds a dampening effect, allowing the valve smoothly to seek set pressure.
- Rotary linkage design eliminates friction and drag.
- Diaphragm chamber and valve body completely isolated to eliminate leakage.
- Wide range of materials for service in most applications.
- Easily adjustable setting for fine tuning in the field.
- Can be set as close as 0.4" WC apart (blanket and recovery).

GENERAL APPLICATION

The 180 Series regulators are designed for use on vapor recovery systems where sensitive control at low pressures is required. They are not recommended for gas tight shut-off applications.

TECHNICAL DATA

Materials:	Aluminum, carbon steel
Sizes:	1" to 8" (25 to 200 mm)
Connections	
1" size:	Threaded
2" to 8" sizes:	Drilled flange
Pressure settings:	-0.4" to 20" WC (-10 to 500 mm WC)

VAREC 180 SERIES PRESSURE REGULATORS

SPECIFICATIONS

OPERATION

The 180 and 186 Series regulators are designed for upstream control, regulating gas in lines going from tanks to vapor recovery compressors.

Upstream pressure sensed through control line piping is applied to one side of the diaphragm. The pressure acts against the weighted lever arm, moving the diaphragm linkage. The movement positions the valve to regulate gas flow. As the upstream pressure of the valve increases, the linkage opens the valve, allowing a greater flow capacity. As the pressure is relieved, the valve throttles toward its closed position.

The 181 and 187 Series regulators are designed for downstream control, including tank blanketing applications.

Downstream pressure sensed through the control line piping is applied to one side of the diaphragm. The pressure acts against the weighted lever arm, moving the diaphragm linkage. The movement positions the valve to regulate gas flow. As the downstream pressure of the valve decreases, the linkage opens the valve, causing an increase in flow capacity. As the pressure increases, the valve throttles toward its closed position.

Sizes

1", 2", 3", 4", 6", 8"

Materials

Body Aluminum
Carbon steel
Trim 304 Stainless steel

Diaphragm housing

180/181 Galvanized steel
186/187 Cast aluminum

Diaphragm

Nylon reinforced NBR
Fiberglass reinforced PTFE
Fiberglass reinforced FKM

Connections

1" Size NPT threaded
2" to 8" Size: Aluminum: drilled to
ANSI 150# FF
Steel: drilled to ANSI 150# RF

Pressure sensing line

180/181 2" Male NPT connection
186/187 1" Female NPT connection

Settings

180/181 0.4" (10 mm) WC vacuum to
1" (25 mm) WC
1" (25 mm) WC to 1.5" (38 mm) WC
186/187 2" (50 mm) WC to 10" (250 mm) WC
10" (250 mm) WC to 20" (500 mm) WC

Downstream vacuum

(Models 180 and 186)
Must remain between atmospheric and
4.91 psig (0.34 barg) vacuum.

Upstream pressure

(Models 181 and 187)
Must remain between atmospheric and
20 psig (1.38 barg).

Pressure differential for full flow

180/181 0.4" (10 mm) WC
186/187 1.5" (38 mm) WC

Repeatability

Will maintain pressure within 0.1" (2.5 mm) WC
of set point.

VAREC 180 SERIES PRESSURE REGULATORS

SPECIFICATIONS

DIMENSIONS, inches and pounds (millimeters and kilograms)

Size code	01	02	03	04	06	08
Nominal pipe size	1 (25)	2 (50)	3 (80)	4 (100)	6 (150)	8 (200)
A	5 (127)	7 11/16 (195)	10 (254)	12 (305)	15 (381)	17 1/2 (445)
B	3 1/8 (79)	4 1/4 (108)	5 1/8 (130)	5 7/8 (149)	7 3/4 (197)	8 3/4 (222)
C	10 1/2 (267)	11 1/8 (283)	12 1/16 (306)	12 11/16 (322)	14 7/16 (370)	15 7/16 (395)
D	10 3/4 (273)	10 3/4 (273)	10 3/4 (273)	10 3/4 (273)	13 1/2 (343)	13 1/2 (343)
E	26 (660)	26 (660)	26 (660)	26 (660)	32 (813)	32 (813)
*	85 (39)	120 (55)	150 (68)	180 (82)	210 (95)	260 (118)

* Shipping weight
Shipping weights are for aluminum construction.

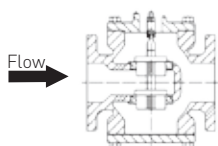
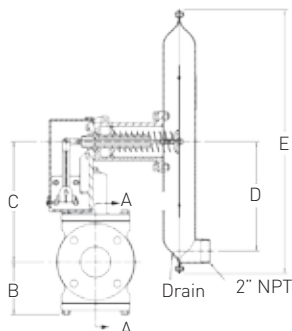
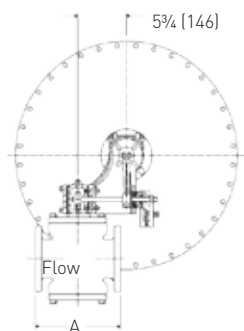

Section A-A - Model 180
Back pressure type (upstream control)

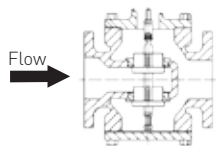

Section A-A - Model 181
Back reducing type (downstream control)

DIMENSIONS, inches and pounds (millimeters and kilograms)

Size code	01	02	03	04	06	08
Nominal pipe size	1 (25)	2 (50)	3 (80)	4 (100)	6 (150)	8 (200)
A	5 (127)	7 11/16 (195)	10 (254)	12 (305)	15 (381)	17 1/2 (444)
B	3 1/8 (79)	4 1/4 (108)	5 1/8 (130)	5 7/8 (149)	7 3/4 (197)	8 3/4 (222)
C	7 (178)	7 7/8 (194)	8 3/16 (217)	9 3/16 (233)	11 1/16 (281)	12 1/16 (306)
*	85 (39)	120 (55)	150 (68)	180 (82)	210 (95)	260 (118)

* Shipping weight
Shipping weights are for aluminum construction.

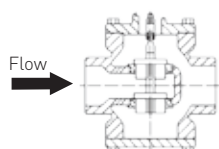
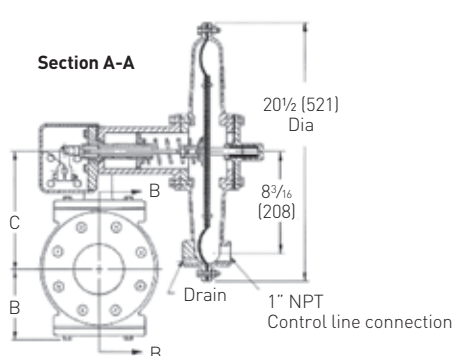
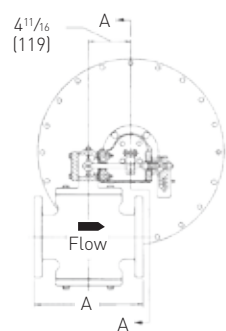

Section B-B - Model 186

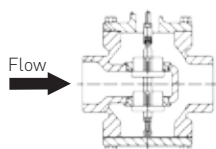

Section B-B - Model 187

Installation, mounting arrangement and dimensions are preliminary general information not be used for construction. Certified drawings are available.

VAREC 180 SERIES PRESSURE REGULATORS

FLOW CURVES

180, 181, 186 AND 187 REGULATORS

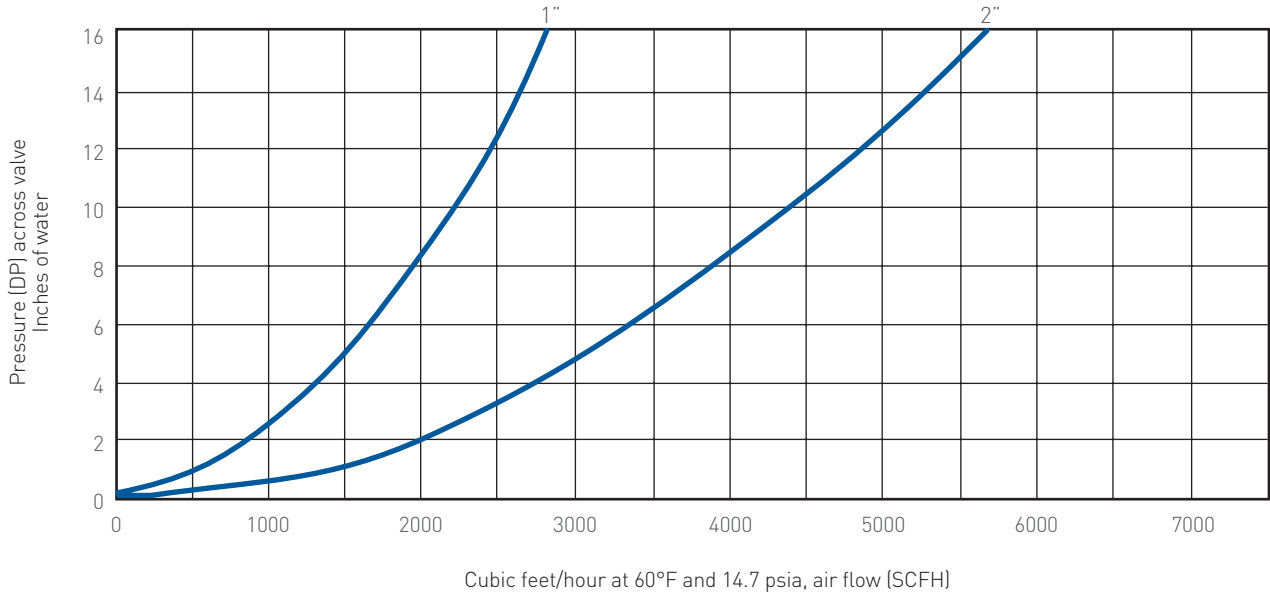

180, 181, 186 AND 187 REGULATORS

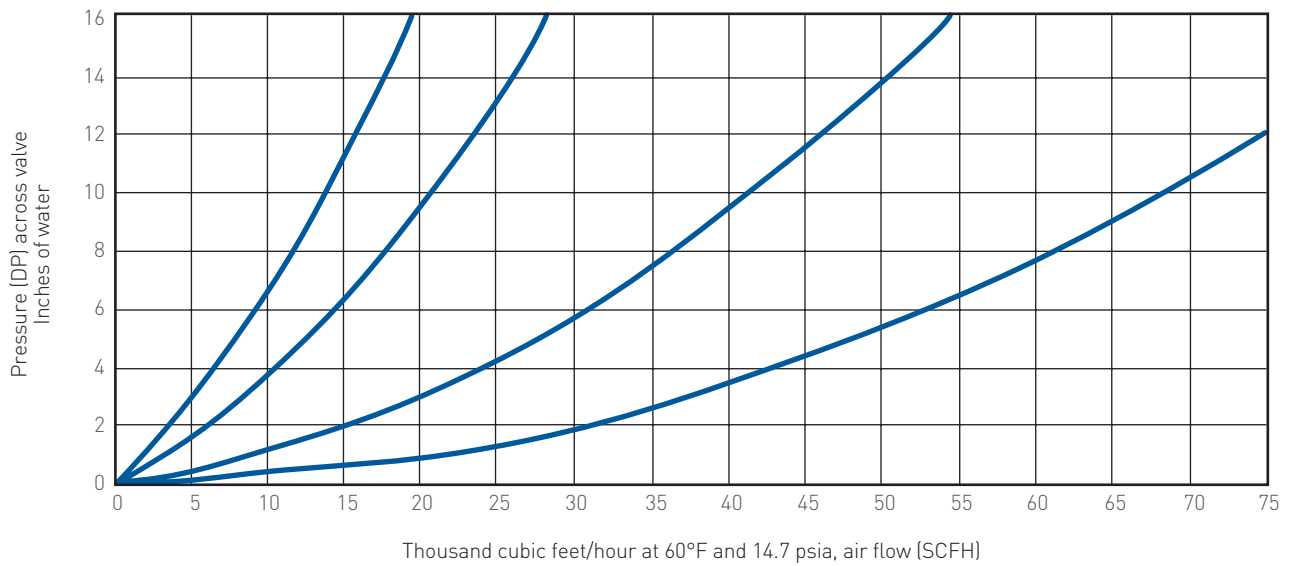

VAREC 180 SERIES PRESSURE REGULATORS

FLOW CURVES

180, 181, 186 AND 187 REGULATORS

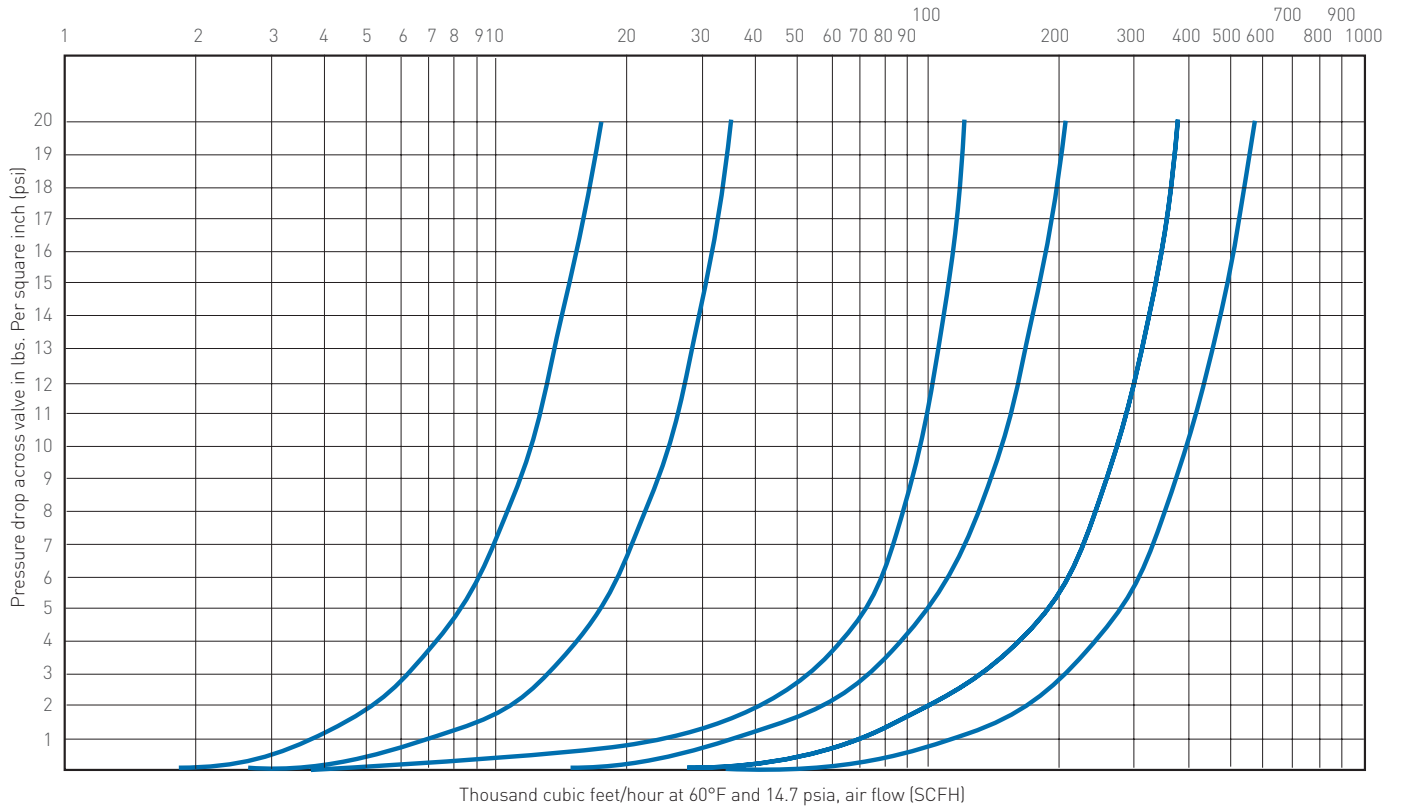

VAREC 180 SERIES PRESSURE REGULATORS

REGULATOR SUMMARY

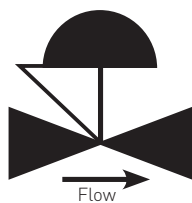
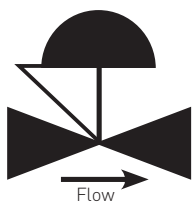
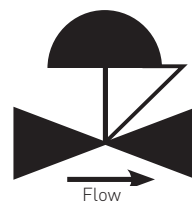
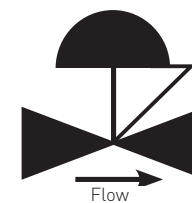
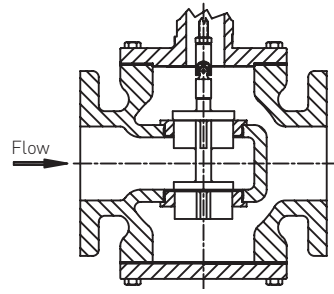
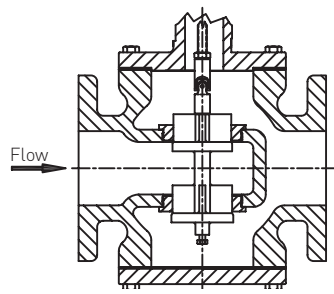
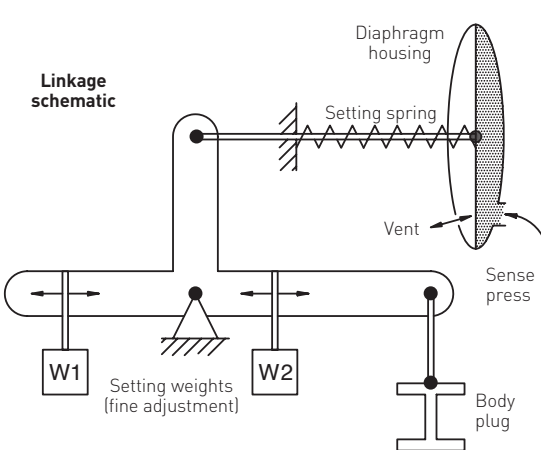
Upstream control (back pressure regulator)		Downstream control (pressure reducing regulator)	
180	186	181	187
			
<p>Upstream</p> <p>Set ranges Low: $-0.4 < 1''$ WC High: $1 < 1.5''$ WC</p> <p>Full open Sense-set $\geq 0.4''$ WC</p>	<p>Downstream</p> <p>Set ranges Low: $2 < 10''$ WC High: $10 < 20''$ WC</p> <p>Max. vacuum 4.91 psig</p>	<p>Upstream</p> <p>Set ranges Low: $-0.4 < 1''$ WC High: $1 < 1.5''$ WC</p> <p>Max. pressure 20 psig</p>	<p>Downstream</p> <p>Set ranges Low: $2 < 10''$ WC High: $10 < 20''$ WC</p> <p>Full open Sense-set $\geq 0.4''$ WC</p> <p>Max. pressure 20 psig</p>
 <p>Body cross section Models 180/186 As upstream pressure increases, the valve opens (lifts).</p>		 <p>Body cross section Models 181/187 As downstream pressure increases, the valve closes (lifts).</p>	
<p>Functional description</p> <p>As the sense pressure increases, the linkage lifts the plug. As the sense pressure decreases, the linkage lowers the plug.</p>  <p>Linkage schematic</p> <p>Diaphragm housing</p> <p>Setting spring</p> <p>Vent</p> <p>Sense press</p> <p>Body plug</p> <p>Setting weights (fine adjustment) W1, W2</p>			

