

Bottom-Unloading Rail Layout

Plan View

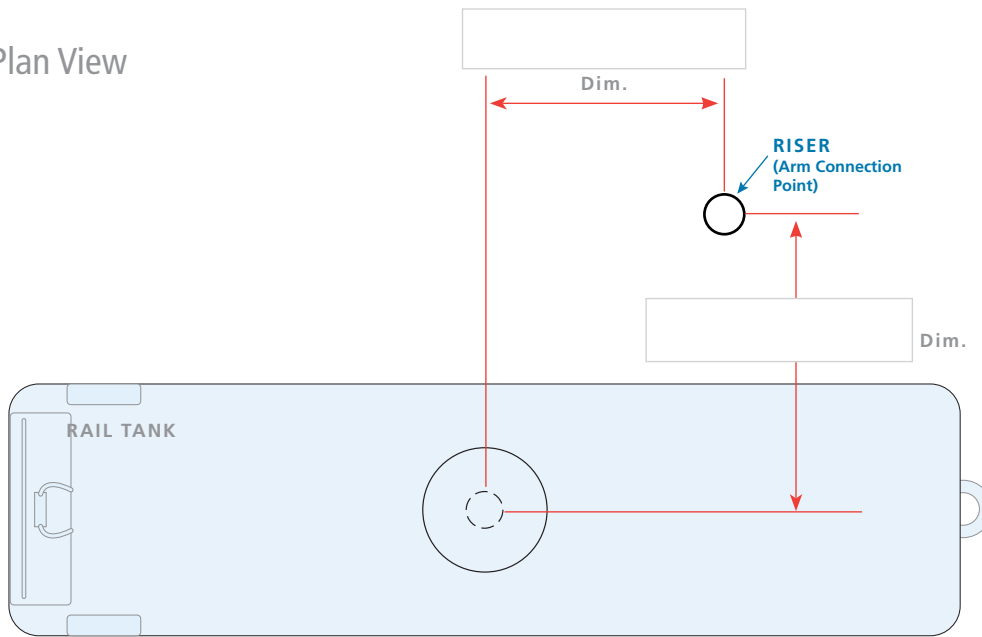

Elevation View

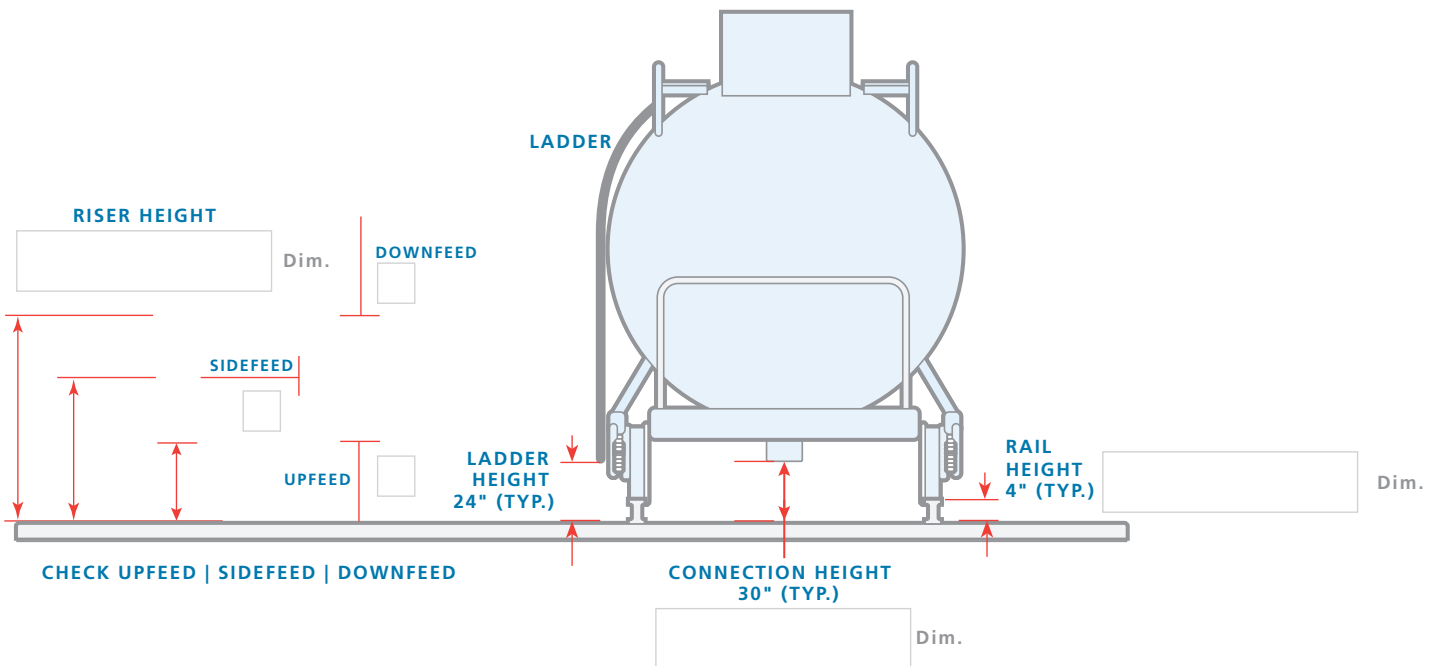

Bottom-Unloading Rail Layout

PROJECT: _____

DATE: _____

END USER: _____

DISTRIBUTOR: _____

REGIONAL MANAGER: _____

LOC/REF#: _____

PRODUCT: _____

PIPE SIZE: _____

FLOW RATE: _____

MAX/MIN TEMP: _____

MAX PRESSURE: _____

WORKING PRESSURE: _____

END CONNECTION: _____

MATERIALS OF CONSTRUCTION:CST SST ALUM OTHER **SEAL MATERIAL:**BUNA FLUOROCARBON PFA EPT NEOPRENE OTHER **CONSTRUCTION DETAIL:**ALL WELDED THREADED FLANGED **STEAM TRACING/JACKETING:**CONDUCTION TRACING FULL STEAM JACKETS

STEAM PRESSURE: _____

ITEMS BY OTHERS/WEIGHT: _____

REQUIRED CERTS:MATERIAL PMI HYDRO TEST OTHER **RADIOGRAPHY:**NONE 5% 10% OTHER **FINISH:**OPW BLUE (STANDARD) OTHER **DRAWING REQUIRED:**NONE GENERAL FULL DETAILED

*Please attach sketch/reference drawing if available.

NOTES