



# model 7501TH

Tempered, Gravity-Fed, Portable Eyewash (Haz Loc)

## FEATURES & BENEFITS

### CONSTRUCTION

FDA approved high-density green polyethylene tank provides the light and durable construction required in a portable unit.

### MOUNTING

J-shaped stainless steel wall bracket makes for a well constructed portable mount for easy removal and re-mount.

### FLOW CONTROLS

Pulling down the eyewash arm will begin flushing the 9-gallon (34.1 L) portable tank at .4 gpm (1.5 L) for a full 15 minutes, creating a full patterned flushing of the eyes.

### DESIGN

Tank comes complete with a wide-fill opening and threaded cap for quick inspection, cleaning, and filling. Unit also comes equipped with top and side handles making relocation easy.

### TEMPERED WATER

Heated, insulated blanket provides ANSI compliant tempered water in operating temperatures to -20° F (-30° C). Unit will stay tempered in non-extreme outdoor conditions (below 100° F (38° C)). Mounted over the Haws model 7501.

### HAZARDOUS LOCATION

Complies with requirements for hazardous locations Class I, Division 2, Groups B, C, D, Temperature code T4; Class II, Division 2, Groups F, G.

## OPTIONS

- Waste Container: Model 9009 is a twenty-gallon (75.7 L) wastewater container constructed of tough yellow polymer resin. Unit is used to collect water during weekly testing of emergency equipment.
- HAWSCLEAN™ Portable Eyewash Cleansing Stick: Model 9083, HawsCLEAN™ cleansing stick for gravity fed and pressurized portable eyewash equipment.
- Water Additive: Model 9082, bacteriostatic preservative for use in portable eyewash stations. One 8 oz. (236 ml) bottle will preserve 5 to 20 gallons (18.9 to 75.7 L) of potable water for up to four months. Four bottles per carton.

For more information, visit [www.hawsco.com](http://www.hawsco.com) or call (888) 640-4297.



## SPECIFICATIONS

Model 7501TH is a 9-gallon (34 L), tempered, compact gravity-fed, hazardous location portable eyewash with a Nema 4 heated, insulated blanket to provide ANSI compliant tempered water in ambient operating temperatures to -20° F (-30° C) and 100° F (38° C). Ideal for remote locations without access to continuous potable water. 120VAC, 60 Hz, 1.38A electrical requirement. The unit includes a FDA approved high-density green polyethylene tank, ABS plastic eyewash heads with .4 gpm (1.5 L) flow rate over 15 minutes, yellow pull-down activation arm, integral handle with "lift here" graphics on top, clearly visible fill line, wide-fill threaded cap, sign-mounted operating instructions, and stainless steel wall bracket (unit must be hung). Power cord not provided - power connection must be made according to code using Class I Division 2 compliant equipment. Voltage options available. Model 9082 additive not included - order separately.

## APPLICATIONS

Where the eyes of any person may be exposed to injurious or corrosive materials, when suitable facilities for quick flushing of the eyes needs to be provided and a continuous supply of water is not available. Although the 7501TH may be installed in a wide variety of locations, it is ideal for remote areas where protective measures are still needed. Emergency eyewash equipment shall be in unobstructed and accessible locations that require no more than 10 seconds for the injured person to reach. CSA certified for NEMA/Type 4 in Class 1, Division 2, Group B, C, D, T6, and Class 2, Division 2, Group F, G locations; and to ANSI/ISEA Z358.1



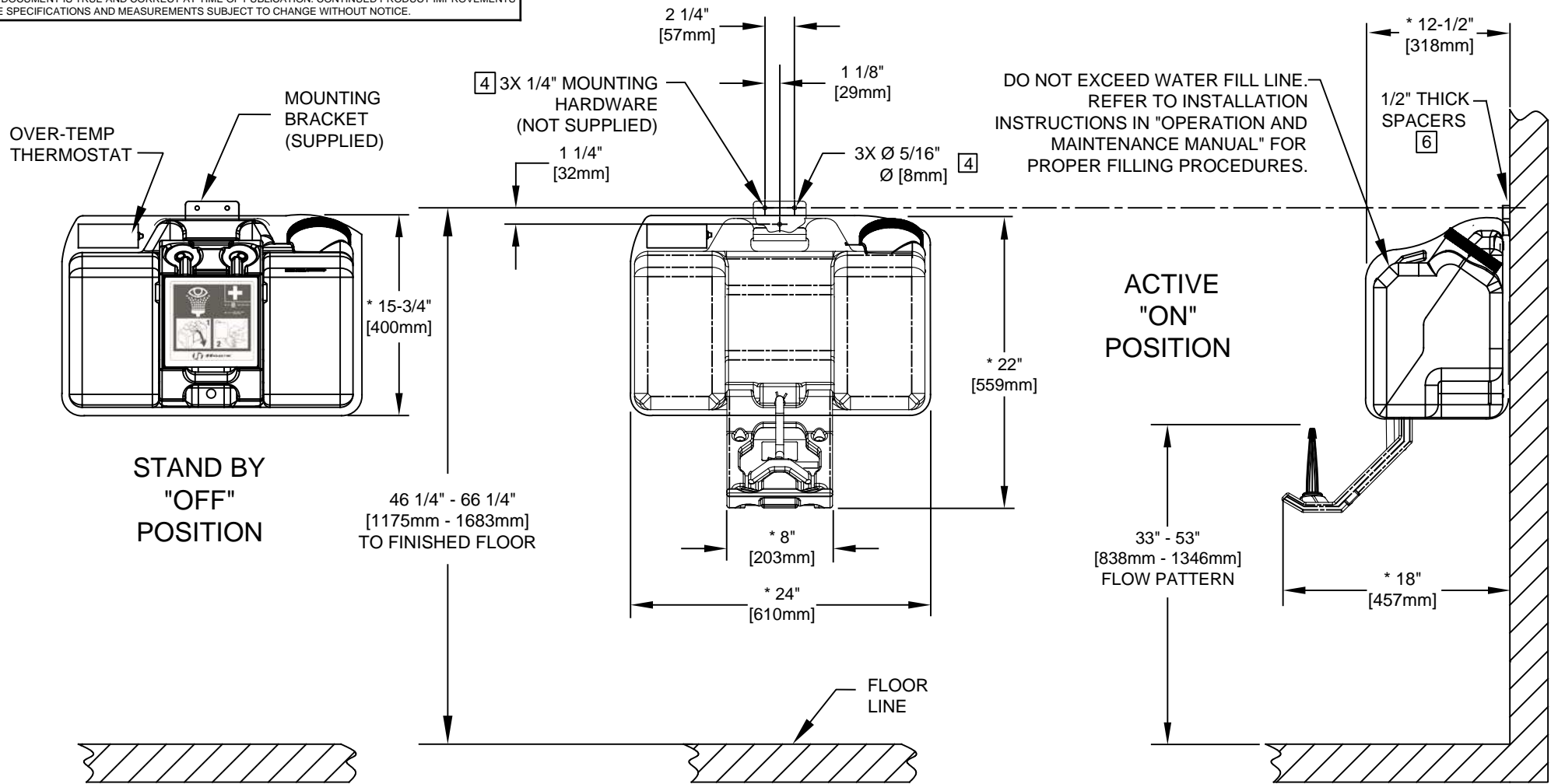

**NOTES:**

1. WHEN INSTALLING THIS UNIT, LOCAL, STATE, OR FEDERAL CODES SHOULD BE ADHERED TO FOR INSTALLATION DIMENSIONS (LOCATIONS), WASTE AND SUPPLY REQUIREMENTS OTHER THAN SHOWN.
2. TO COMPLY WITH ANSI Z358.1-2014 FOR EMERGENCY EYEWASH OR EYE/FACE WASH: EYEWASH OR EYE/FACE WASH SHALL BE POSITIONED SUCH THAT FLUSHING FLUID PATTERN IS NOT LESS THAN 33" (838mm) AND NO GREATER THAN 53" (1346 mm) FROM SURFACE ON WHICH USER STANDS; AND 6.0" (153mm) MINIMUM FROM WALL OR NEAREST OBSTRUCTION.
3. UNIT MUST BE LEVEL FROM FRONT TO BACK AND SIDE TO SIDE.
4. ALL THREE MOUNTING HOLES ON MOUNTING-BRACKET MUST BE USED TO PROPERLY SECURE EYEWASH UNIT TO WALL.
5. DIMENSIONS MAY VARY ±1/2" [12.7 mm]
6. LOCATE ONE 1/2" THICK SPACER (QTY. 3 SUPPLIED) BEHIND EACH HOLE IN THE MOUNTING BRACKET AS SHOWN.
7. UNIT MUST BE FILLED WITH WATER BEFORE CONNECTING TO POWER SOURCE.
8. ALL MODELS MUST HAVE A GROUND FAULT PROTECTION DEVICE (30mA GFCI) FOR HEAT TRACE. ELECTRICAL CURRENTS MAY BE INSUFFICIENT TO TRIP A CONVENTIONAL CIRCUIT BREAKER. ALL INSTALLATIONS MUST BE INSTALLED IN COMPLIANCE WITH LOCAL, STATE, AND/OR FEDERAL CODES.

9. ALL POWER CONNECTIONS MUST BE MADE ACCORDING TO NEC/CEC CODE USING FLEXIBLE CONDUIT OR CABLE RATED FOR CLASS I, II, DIVISION 2 – NO RIGID CONNECTION PERMITTED. MODEL 7501TH/7501T240H REQUIRES MINIMUM NEMA/TYPER 4 COMPLIANT EQUIPMENT. THE CORD AND FITTINGS SELECTED MUST HAVE THE APPROPRIATE HAZARDOUS LOCATION RATING REQUIRED FOR THE INSTALLATION LOCATION.

MOUNTING DETAILS FOR:  
MODELS 7501TH/7501T240H - WITH HEATED BLANKET SHOWN.

		1455 KLEPPE LANE SPARKS, NEVADA 89431 (775) 359-4712 FAX (775) 359-7424 E-MAIL: HAWS@HAWS.CO.COM WEBSITE: WWW.HAWS.CO.COM	
ECN NO. 5235 DRAWN: CC APPROVED: IR	REVISED PER: DB ECN: 5471 DATE: 12/28/17 DATE: 03/18/20	MODEL(S) PORTABLE EYEWASH 7501TH/7501T240H	PART NUMBER 0510000808.D REVISION 2
SCALE: 1:1		DRAWING TYPE: INSTALLATION	SIZE: A SHEET 1 OF 1