

Rosemount™ 3051S Series of Instrumentation



Innovation reaching across your operation

With the Rosemount 3051S Series of Instrumentation, operations can be optimized in these critical areas: production, quality, energy efficiency, and safety and environment. By leveraging the power of the scalable Rosemount 3051S across the entire operation, you'll be able to minimize process variability, gain greater process insight, reduce maintenance and downtime, and meet regulatory demands. What's more, it's easy to use, ensuring the full potential of the measurement investment is realized.

Overview

Rosemount 3051S SuperModule™ Platform

The most advanced pressure, flow, and level measurements



- The all-welded hermetic SST design delivers the industry's highest field reliability.
- Ultra performance provides up to $\pm 0.025\%$ accuracy and 200:1 rangedown.
- Ultra for Flow performance provides up to $\pm 0.04\%$ of reading and 14:1 flow turn-down.
- 15-year stability and 15-year limited warranty
- SIL3 Capable: IEC 61508 certified by an accredited 3rd party agency for use in safety instrumented systems up to SIL 3 (minimum requirement of single use [1oo1] for SIL 2 and redundant use [1oo2] for SIL 3).
- IEC 61508 Functional Safety Specifications for 3051S are detailed at Emerson.com/Rosemount/Safety.

Contents

Overview	2
Rosemount 3051S Coplanar Pressure Transmitter	6
Rosemount 3051S In-line Pressure Transmitter	15
Rosemount 3051S MultiVariable Transmitter	21
Rosemount 3051SF DP Flow Meters	30
Rosemount 3051S Electronic Remote Sensor (ERS) System	56
Rosemount 3051S Scalable Level Transmitter	73
Specifications	100
Product Certifications	131
Dimensional drawings	160
Accessories	176

Rosemount 3051S Series selection guide

Rosemount 3051S Coplanar™ Differential, Gage, or Absolute Transmitter



Ordering information: [Table 1](#)

- Coplanar platform enables integrated manifold, primary element, and seal system solutions.
- Dual-capacitance Saturn™ sensor technology corrects for overpressure and line pressure effects.
- Calibrated spans from 0.1 inH₂O to 4000 psi (0,25 mbar to 276 bar).
- Available with 316L SST, Alloy C-276, Alloy 400, Tantalum, gold-plated Alloy 400, or gold-plated 316L SST process isolators

Rosemount 3051S In-line Gage or Absolute Transmitter



Ordering information: [Table 2](#)

- Direct threaded connection, manifold or seal system solutions
- Piezoresistive sensor technology allows calibrated spans from 0.3 to 10000 psi (20,7 mbar to 689 bar).
- Available with 316L SST or Alloy C-276 process isolators

Rosemount 3051S MultiVariable™ Transmitter



Ordering information: [Table 3](#)

- Combines Differential Pressure, Static Pressure, and Process Temperature measurements along with Mass and Energy Flow in a single device.
- Compensates for 25+ different variables providing accurate and repeatable flow readings.
- Customize pressure and temperature compensation for any flow application.
- Easily configure flow and device parameters with Engineering Assistant Software.

Rosemount 3051SF DP Flow Meters



Ordering information: [Table 4](#)

- Integrates the Rosemount 3051S with Rosemount's industry leading primary elements to create one complete flow meter assembly.
- Fully assembled, configured and leak tested for out-of-the-box installation.
- Reduce installed costs by replacing ten parts traditionally used for a DP Flow installation with one flow meter.
- Reduce straight pipe requirements, lower permanent pressure loss, and achieve accurate measurement in small line sizes.

Rosemount 3051S Electronic Remote Sensor (ERS™) System



Rosemount 3051SAM Transmitter Ordering information: [Table 7](#)

Rosemount 3051SAL Transmitter Ordering information: [Table 8](#)

- The industry's first digital DP Level architecture consists of a single 4–20 mA HART® loop with two Rosemount 3051S pressure sensors connected electronically.
- Unique digital architecture enables stable and repeatable DP Level measurements on tall vessels, towers, and applications with wide-varying temperatures.
- Achieve increased process insight and diagnostics with multivariable measurements including DP, pressure, and scaled variable for tank level or volume.
- Simplify installations and maintenance by eliminating wet or dry legs, heat tracing, and purge systems.

Rosemount 3051S Level Transmitter



Ordering information: [Table 9](#)

- Level transmitters combine world-class Rosemount 3051S Pressure Transmitters with direct mount seals, all in a single integrated model number.
- Connect to virtually any process with a comprehensive offering of seal types, sizes, fill fluids, and diaphragm materials.
- Combine with an Rosemount 1199 Remote Mount Seal to form a Tuned-System™ Assembly for a cost effective, easy-to-install DP Level measurement solution.

Advanced functionality

WirelessHART® (IEC 62591) capabilities



The following functionality is available on coplanar, in-line, multivariable, DP flow meters and level transmitters:

- Quickly deploy new pressure, level and flow measurements in 70 percent less time.
- Eliminate wiring design and construction complexities to lower costs by 40–60 percent.
- Reduce pipe penetrations and impulse piping with industry-leading multivariable technology.
- Extended range antenna capabilities provide access to remote locations.
- Delivering over a decade of maintenance free performance with 15-year stability and 10-year power module life.

Advanced diagnostic capabilities



The following functionality is available on coplanar, in-line, DP flow meters and level transmitters:

- Provides diagnostic coverage from the process to the transmitter to the host.
- Prevent on-scale failures by diagnosing electrical loop issues with loop integrity diagnostics.
- Process intelligence detects abnormal process conditions enabling more productive and safer operations.
- Monitor for solids build-up or freezing in the process connection with the plugged impulse line diagnostic.
- Extend diagnostic coverage to Safety Instrumented Systems with IEC 61508 SIL 2/3 capable rating.

Remote display and interface



The following functionality is available on coplanar, in-line, DP flow meters, Electronic Remote Sensors, and level transmitters:

- Direct mount to the process and access transmitter capabilities and diagnostics at grade.
- Get access up to 100 feet (30 m) away from the process to ensure personnel safety.
- Eliminate the need for impulse lines for best practice installations.

Rosemount instrument manifolds



Available on traditional, coplanar, and in-line transmitters:

- Designed and engineered to provide optimal performance with Rosemount 3051S Transmitters.
- Reduce cost and leak points with flangeless coplanar design.
- Fully integrated manifold and transmitter assemblies come fully leak checked, calibrated and assembled allowing for one purchase order to save time and cost.
- Rosemount manifolds provide a wide variety of styles, materials, and configurations to fit any process.

Rosemount™ 3051S Coplanar™ Pressure Transmitter



Rosemount 3051S Coplanar Pressure Transmitters are the industry leader for Differential, Gage, and Absolute pressure measurement. The coplanar platform allows seamless integration with manifolds, primary elements, and seal solutions. Capabilities include:

- Ultra, ultra for flow, and classic performance
- 4–20 mA HART®, WirelessHART®, FOUNDATION™ Fieldbus protocols
- Safety Certification (Option code QT)
- Advanced diagnostics (Option code DA2)
- Remote display and interface (Option code M7, M8, or M9)

Additional information: [Specifications](#), [Rosemount 3051S/3051Sfx/3051S-ERS](#), [Dimensional drawings](#)

Specification and selection of product materials, options, or components must be made by the purchaser of the equipment. See [Material selection](#) for more information.

The starred offerings (★) represent the most common options and should be selected for best delivery. The non-starred offerings are subject to additional delivery lead time.

Table 1: Rosemount 3051S Scalable™ Coplanar Pressure Transmitter Ordering Information

Model	Transmitter type			
3051S	Scalable pressure transmitter			
Performance class⁽¹⁾				
1	Ultra: 0.025% span accuracy, 200:1 rangedown, 15-yr stability, 15-yr limited warranty			★
3 ⁽²⁾	Ultra for Flow: 0.04% reading accuracy, 200:1 turndown, 15-yr stability, 15-yr limited warranty			★
2	Classic: 0.035% span accuracy, 150:1 rangedown, 15-yr stability			★
Connection type				
C	Coplanar			★
Measurement type⁽³⁾				
D	Differential			★
G	Gage			★
A	Absolute			
Pressure range				
	Differential	Gage	Absolute	
1A	-25 to 25 inH ₂ O (-62,16 to 62,16 mbar)	-25 to 25 inH ₂ O (-62,16 to 62,16 mbar)	0 to 30 psia (0 to 2,07 bar)	★
2A	-250 to 250 inH ₂ O (-621,60 to 621,60 mbar)	-250 to 250 inH ₂ O (-621,60 to 621,60 mbar)	0 to 150 psia (0 to 10,34 bar)	★
3A	-1000 to 1000 inH ₂ O (-2,49 to 2,49 bar)	-393 to 1000 inH ₂ O (-0,97 to 2,49 bar)	0 to 800 psia (0 to 55,16 bar)	★
4A	-300 to 300 psi (-20,68 to 20,68 bar)	-14.2 to 300 psig (-0,97 to 20,68 bar)	0 to 4000 psia (0 to 275,79 bar)	★

Table 1: Rosemount 3051S Scalable™ Coplanar Pressure Transmitter Ordering Information (continued)

5A	-2000 to 2000 psi (-137,89 to 137,89 bar)	-14.2 to 2000 psig (-0,97 to 137,89 bar)	N/A			★
0A ⁽⁴⁾	-3 to 3 inH ₂ O (-7,46 to 7,46 mbar)	N/A	0 to 5 psia (0 to 0,34 bar)			
Isolating diaphragm						
2 ⁽⁵⁾	316L SST					★
3 ⁽⁵⁾	Alloy C-276					★
4 ⁽⁵⁾	Alloy 400					
5 ⁽⁶⁾	Tantalum					
6 ⁽⁵⁾	Gold-plated Alloy 400 (includes graphite-filled PTFE O-ring)					
7 ⁽⁵⁾	Gold-plated 316L SST					
Process connection		Size	Materials of construction			
			Flange material	Drain vent	Bolting	
000	None (no process flange)	N/A	N/A	N/A	N/A	★
A11 ⁽⁷⁾	Assemble to Rosemount 305 integral manifold	N/A	N/A	N/A	N/A	★
A12 ⁽⁷⁾	Assemble to Rosemount 304 or AMF manifold and SST traditional flange	N/A	N/A	N/A	N/A	★
A15	Assemble to Rosemount 304 or AMF manifold to SST traditional flange with Alloy C-276 drain vents	N/A	N/A	N/A	N/A	★
A16 ⁽⁷⁾	Assemble to 304 or AMF manifold to DIN SST traditional flange	N/A	N/A	N/A	N/A	★
A22	Assemble to Rosemount 304 or AMF manifold to SST coplanar flange	N/A	N/A	N/A	N/A	★
B11 ⁽⁷⁾⁽⁸⁾⁽⁹⁾	Assemble to one Rosemount 1199 seal	N/A	SST	N/A	N/A	★
B12 ⁽⁷⁾⁽⁸⁾⁽⁹⁾	Assemble to two Rosemount 1199 seals	N/A	SST	N/A	N/A	★
C11 ⁽⁷⁾	Assemble to Rosemount 405C or 405P primary element	N/A	N/A	N/A	N/A	★
D11 ⁽⁷⁾	Assemble to Rosemount 1195 integral orifice and Rosemount 305 integral manifold	N/A	N/A	N/A	N/A	★
EA2 ⁽⁷⁾	Assemble to Rosemount 485 or 405A Annubar™ primary element with coplanar flange	N/A	SST	316 SST	N/A	★
EA3 ⁽⁷⁾	Assemble to Rosemount 485 or 405A Annubar primary element with coplanar flange	N/A	Cast C-276	Alloy C-276	N/A	★
EA5 ⁽⁷⁾	Assemble to Rosemount 485 or 405A Annubar primary element with coplanar flange	N/A	SST	Alloy C-276	N/A	★

Table 1: Rosemount 3051S Scalable™ Coplanar Pressure Transmitter Ordering Information (continued)

E11	Coplanar flange	¼-18 NPT	CS	316 SST	N/A	★
E12	Coplanar flange	¼-18 NPT	SST	316 SST	N/A	★
E13 ⁽⁵⁾	Coplanar flange	¼-18 NPT	Cast C-276	Alloy C-276	N/A	★
E14	Coplanar flange	¼-18 NPT	Cast Alloy 400	Alloy 400/K-500	N/A	★
E15 ⁽⁵⁾	Coplanar flange	¼-18 NPT	SST	Alloy C-276	N/A	★
E16 ⁽⁵⁾	Coplanar flange	¼-18 NPT	CS	Alloy C-276	N/A	★
E21	Coplanar flange	RC ¼	CS	316 SST	N/A	★
E22	Coplanar flange	RC ¼	SST	316 SST	N/A	★
E23 ⁽⁵⁾	Coplanar flange	RC ¼	Cast C-276	Alloy C-276	N/A	★
E24	Coplanar flange	RC ¼	Cast Alloy 400	Alloy 400/K-500	N/A	★
E25 ⁽⁵⁾	Coplanar flange	RC ¼	SST	Alloy C-276	N/A	★
E26 ⁽⁵⁾	Coplanar flange	RC ¼	CS	Alloy C-276	N/A	★
F12	Traditional flange	¼-18 NPT	SST	316 SST	N/A	★
F13 ⁽⁵⁾	Traditional flange	¼-18 NPT	Cast C-276	Alloy C-276	N/A	★
F14	Traditional flange	¼-18 NPT	Cast Alloy 400	Alloy 400/K-500	N/A	★
F15 ⁽⁵⁾	Traditional flange	¼-18 NPT	SST	Alloy C-276	N/A	★
F22	Traditional flange	RC ¼	SST	316 SST	N/A	★
F23 ⁽⁵⁾	Traditional flange	RC ¼	Cast C-276	Alloy C-276	N/A	★
F24	Traditional flange	RC ¼	Cast Alloy 400	Alloy 400/K-500	N/A	★
F25 ⁽⁵⁾	Traditional flange	RC ¼	SST	Alloy C-276	N/A	★
F52	DIN-compliant traditional flange	¼-18 NPT	SST	316 SST	7/16-in. bolt- ing	★
G11	Vertical mount level flange	2-in. ANSI Class 150	SST	316 SST	N/A	★
G12	Vertical mount level flange	2-in. ANSI Class 300	SST	316 SST	N/A	★
G21	Vertical mount level flange	3-in. ANSI Class 150	SST	316 SST	N/A	★
G22	Vertical mount level flange	3-in. ANSI Class 300	SST	316 SST	N/A	★
G31	Vertical mount level flange	DIN- DN 50 PN 40	SST	316 SST	N/A	★
G41	Vertical mount level flange	DIN- DN 80 PN 40	SST	316 SST	N/A	★
F32	Bottom vent traditional flange	¼-18 NPT	SST	316 SST	N/A	
F42	Bottom vent traditional flange	RC ¼	SST	316 SST	N/A	
F62	DIN-compliant traditional flange	¼-18 NPT	SST	316 SST	M10 bolting	
F72	DIN-compliant traditional flange	¼-18 NPT	SST	316 SST	M12 bolting	
Transmitter output						
A	4–20 mA with digital signal based on HART protocol					★
F ⁽¹⁰⁾	FOUNDATION Fieldbus protocol					★
X ⁽¹¹⁾	Wireless (requires wireless options and wireless Plantweb™ housing)					★
Housing style				Material	Conduit entry size	
00	None (SuperModule spare part, order output code A)			N/A	N/A	★

Table 1: Rosemount 3051S Scalable™ Coplanar Pressure Transmitter Ordering Information (continued)

1A	Plantweb housing	Aluminum	½–14 NPT	★
1B	Plantweb housing	Aluminum	M20 x 1.5	★
1J	Plantweb housing	SST	½–14 NPT	★
1K	Plantweb housing	SST	M20 x 1.5	★
5A ⁽¹²⁾	Wireless Plantweb housing	Aluminum	½–14 NPT	★
5J ⁽¹²⁾	Wireless Plantweb housing	SST	½–14 NPT	★
2A	Junction box housing	Aluminum	½–14 NPT	★
2B	Junction box housing	Aluminum	M20 x 1.5	★
2J	Junction box housing	SST	½–14 NPT	★
2E	Junction box housing with output for remote display and interface	Aluminum	½–14 NPT	★
2F	Junction box housing with output for remote display and interface	Aluminum	M20 x 1.5	★
2M	Junction box housing with output for remote display and interface	SST	½–14 NPT	★
7J ⁽¹³⁾	Quick connect (A size mini, 4-pin male termination)	SST	N/A	★
1C	Plantweb housing	Aluminum	G½	
1L	Plantweb housing	SST	G½	
2C	Junction box housing	Aluminum	G½	
2G	Junction box housing with output for remote display and interface	Aluminum	G½	
Wireless options (requires option code X and wireless Plantweb housing)				
Update rate				
WA	User configurable update rate			★
Operating frequency and protocol				
3	2.4 GHz DSSS, IEC 62591 (<i>WirelessHART</i>)			★
Omni-directional wireless antenna				
WK	External antenna			★
WM	Extended range, external antenna			★
WJ	Remote antenna			★
WN	High-gain, remote antenna			
SmartPower™⁽¹⁴⁾				
1	Adapter for black power module (I.S. Power Module sold separately)			★
Other options (include with selected model number)				
HART Revision configuration (requires HART Protocol output code A)⁽¹⁵⁾				
HR7	Configured for HART Revision 7			★
Extended product warranty				
WR3	3-year limited warranty			★
WR5	5-year limited warranty			★
Plantweb control functionality				
A01	FOUNDATION Fieldbus advanced control function block suite			★

Table 1: Rosemount 3051S Scalable™ Coplanar Pressure Transmitter Ordering Information (continued)

Diagnostics suite		
D01	FOUNDATION Fieldbus diagnostics suite (Process Intelligence, Plugged Impulse Line diagnostic)	★
DA2 ⁽¹⁶⁾	Advanced HART diagnostics suite (Process Intelligence, Loop Integrity, Plugged Impulse Line diagnostic, Process Alerts, Service Alerts, Variable Log, Event Log)	★
Mounting bracket⁽¹⁷⁾		
B4	Coplanar flange bracket, all SST, 2-in. pipe and panel	★
B1	Traditional flange bracket, CS, 2-in. pipe	★
B2	Traditional flange bracket, CS, panel	★
B3	Traditional flange flat bracket, CS, 2-in. pipe	★
B7	Traditional flange bracket, B1 with SST bolts	★
B8	Traditional flange bracket, B2 with SST bolts	★
B9	Traditional flange bracket, B3 with SST bolts	★
BA	Traditional flange bracket, B1, all SST	★
BC	Traditional flange bracket, B3, all SST	★
BE	316SST B4-style bracket with 316SST bolting	★
Software configuration		
C1 ⁽¹⁸⁾	Custom software configuration (requires Configuration Data Sheet)	★
C2	Custom flow configuration (requires H01 and Configuration Data Sheet)	★
Gage pressure calibration		
C3	Gage pressure calibration on Rosemount 3051S_CA4 only	★
Alarm limit ⁽¹⁸⁾⁽¹⁹⁾		
C4	NAMUR alarm and saturation levels, high alarm	★
C5	NAMUR alarm and saturation levels, low alarm	★
C6	Custom alarm and saturation signal levels, high alarm (requires C1 and Configuration Data Sheet)	★
C7	Custom alarm and saturation signal levels, low alarm (requires C1 and Configuration Data Sheet)	★
C8	Low alarm (standard Rosemount alarm and saturation levels)	★
Hardware adjustments⁽¹⁸⁾⁽¹⁹⁾⁽²⁰⁾		
D1	Hardware adjustments (zero, span, alarm, security)	★
Flange adapter⁽²¹⁾		
D2	½-14 NPT flange adapter	★
D9	RC½ SST flange adapter	
Custody transfer⁽²²⁾		
D3	Measurement Canada accuracy approval	★
Ground screw⁽²³⁾		
D4	External ground screw assembly	★
Drain/vent valve⁽²¹⁾		
D5	Delete transmitter drain/vent valves (install plugs)	★
D7	SST coplanar flange without drain/vent ports	

Table 1: Rosemount 3051S Scalable™ Coplanar Pressure Transmitter Ordering Information (continued)

Conduit plug ⁽²⁴⁾		
DO	316 SST conduit plug	★
Product certifications ⁽²⁵⁾		
E1	ATEX Flameproof	★
I1	ATEX Intrinsic Safety	★
IA	ATEX FISCO Intrinsic Safety (FOUNDATION fieldbus protocol only)	★
N1	ATEX Type n	★
K1	ATEX Flameproof, Intrinsic Safety, Type n, Dust	★
ND	ATEX Dust	★
E4	TIIS Flameproof	★
I4 ⁽¹²⁾	TIIS Intrinsic Safety	★
E5	FM Explosion-proof, Dust Ignition-proof	★
I5	FM Intrinsically Safe; Nonincendive	★
IE	FM FISCO Intrinsically Safe (FOUNDATION Fieldbus protocol only)	★
K5	FM Explosion-proof, Dust Ignition-proof, Intrinsically Safe, Division 2	★
E6 ⁽²⁶⁾	CSA Explosion-proof, Dust Ignition-proof, Division 2	★
I6	CSA Intrinsically Safe	★
IF	CSA FISCO Intrinsically Safe (FOUNDATION Fieldbus protocol only)	★
K6 ⁽²⁶⁾	CSA Explosion-proof, Dust Ignition-proof, Intrinsically Safe, Division 2	★
E7	IECEX Flameproof, Dust	★
I7	IECEX Intrinsic Safety	★
IG	IECEX FISCO Intrinsic Safety (FOUNDATION Fieldbus protocol only)	★
N7	IECEX Type n	★
K7	IECEX Flameproof, Dust, Intrinsic Safety, Type n	★
E2	INMETRO Flameproof	★
I2	INMETRO Intrinsic Safety	★
IB	INMETRO FISCO Intrinsic Safety	★
K2	INMETRO Flameproof, Intrinsic Safety	★
E3	China Flameproof	★
I3	China Intrinsic Safety	★
N3	China Type n	★
EP	Korea Flameproof	★
IP	Korea Intrinsic Safety	★
KP	Korea Flameproof, Intrinsic Safety	★
EM	Technical Regulations Customs Union (EAC) Flameproof	★
IM	Technical Regulations Customs Union (EAC) Intrinsic Safety	★
KM	Technical Regulations Customs Union (EAC) Flameproof, Intrinsic Safety	★
KA ⁽²⁶⁾	ATEX and CSA Flameproof, Intrinsically Safe, Division 2	★

Table 1: Rosemount 3051S Scalable™ Coplanar Pressure Transmitter Ordering Information (continued)

KB ⁽²⁶⁾	FM and CSA Explosion-proof, Dust Ignition-proof, Intrinsically Safe, Division 2	★
KC	FM and ATEX Explosion-proof, Intrinsically Safe, Division 2	★
KD ⁽²⁶⁾	FM, CSA, and ATEX Explosion-proof, Intrinsically Safe	★
KG	FM, CSA, ATEX and IECEx FISCO Intrinsic Safety	★
KQ	USA, Canada, ATEX Intrinsic Safety Combination	★
KS	USA, Canada, IECEx, ATEX Explosion Proof, Intrinsically Safe, Dust, Non-Incendive, Type-N, Division 2	★
Shipboard approvals		
SBS	American Bureau of Shipping	★
SBV	Bureau Veritas (BV) Type Approval	★
SDN	Det Norske Veritas (DNV) Type Approval	★
SLL	Lloyds Register (LR) Type Approval	★
Stainless steel tagging		
Y2	316SST nameplate, top tag, wire-on tag, and fasteners	★
Sensor fill fluid⁽²⁷⁾		
L1	Inert sensor fill fluid	★
O-ring		
L2	Graphite-filled PTFE O-ring	★
Bolting material⁽²¹⁾		
L4	Austenitic 316 SST bolts	★
L5	ASTM A 193, Grade B7M bolts	★
L6	Alloy K-500 bolts	★
L7 ⁽²⁸⁾	ASTM A453, Class D, Grade 660 bolts	★
L8	ASTM A193, Class 2, Grade B8M bolts	★
Display type⁽²⁹⁾		
M5	Plantweb LCD display	★
M7 ⁽¹⁹⁾⁽³⁰⁾⁽³¹⁾	Remote mount LCD display and interface, Plantweb housing, no cable, SST bracket	★
M8 ⁽¹⁹⁾⁽³⁰⁾	Remote mount LCD display and interface, Plantweb housing, 50 feet (15 m) cable, SST bracket	★
M9 ⁽¹⁹⁾⁽³⁰⁾	Remote mount LCD display and interface, Plantweb housing, 100 feet (31 m) cable, SST bracket	★
Pressure testing⁽³²⁾		
P1	Hydrostatic testing with certificate	
Special cleaning⁽²¹⁾		
P2	Cleaning for special services	
P3	Cleaning for special services with testing for <1PPM chlorine/fluorine	
Maximum static line pressure		
P9 ⁽³³⁾	4500 psig (310 bar) static pressure limit (Rosemount 3051S_CD only)	★
P0 ⁽³⁴⁾	6092 psig (420 bar) static pressure limit (Rosemount 3051S2CD only)	★
Calibration certification		
Q4	Calibration certificate	★

Table 1: Rosemount 3051S Scalable™ Coplanar Pressure Transmitter Ordering Information (continued)

QP	Calibration certificate and tamper evident seal	★
Material traceability certification		
Q8	Material traceability certification per EN 10204 3.1	★
Quality certification for safety⁽³⁵⁾		
QS	Prior-use certificate of FMEDA data	★
QT	Safety-certified to IEC 61508 with certificate of FMEDA data	★
Transient protection⁽³⁶⁾⁽³⁷⁾		
T1	Transient terminal block	★
Drinking water approval⁽³⁸⁾		
DW	NSF drinking water approval	★
Surface finish certification		
Q16	Surface finish certification for sanitary remote seals	★
Toolkit total system performance reports		
QZ	Remote seal system performance calculation report	★
Conduit electrical connector⁽³⁹⁾		
GE	M12, 4-pin, male connector (eurofast®)	★
GM	A size mini, 4-pin, male connector (minifast®)	★
NACE® certificate⁽⁴⁰⁾		
Q15	Certificate of compliance to NACE MR0175/ISO 15156 for wetted materials	★
Q25	Certificate of compliance to NACE MR0103 for wetted materials	★
Thread sealants		
Z1	High temperature liquid thread sealant (-65 to 400 °F temperature rating)	★
Z2	Liquid thread sealant (-63 to 302 °F temperature rating)	★
Z3	Anaerobic PTFE paste	★
Typical model number: 3051S1CD 2A 2 E12 A 1A DA2 B4 M5		

(1) For details, see [Specifications](#).

(2) This option is only available with range codes 2A and 3A, 316L SST or Alloy C-276 isolating diaphragm and silicone fill fluid.

(3) Performance Class code 3 is available with Measurement Type code D only.

(4) 3051S_CD0 is only available with SST traditional flange, 316L SST diaphragm material, and Bolting option L4.

(5) Materials of Construction comply with metallurgical requirements highlighted within NACE MR0175/ISO 15156 for sour oil field production environments. Environmental limits apply to certain materials. Consult latest standard for details. Selected materials also conform to NACE MR0103 for sour refining environments. Order with Q15 or Q25 to receive a NACE certificate.

(6) Tantalum diaphragm material is only available for ranges 2A–5A, differential and gage.

(7) “Assemble to” items are specified separately and require a completed model number. Process connection option codes B12, C11, D11, EA2, EA3, and EA5 are only available on differential Measurement Type, code D.

(8) Consult an Emerson™ representative for performance specifications.

(9) Not available with Performance Class code 3.

(10) Requires Plantweb housing.

(11) Only intrinsically safe approval codes apply.

(12) Only available with output code X.

(13) Available with output code A only. Available approvals are FM Intrinsically Safe; Nonincendive (option code I5), CSA Intrinsically Safe (option code I6), ATEX Intrinsic Safety (option code I1), or IECEx Intrinsic Safety (option code I7). Contact an Emerson representative for additional information.

(14) Long-Life Power Module must be shipped separately, order Power Module 701PBKFF.

- (15) Option HR7 configures the HART output to HART Revision 7. This option requires the selection of the Advanced Diagnostics (DA2) option. The device with this option can be field configured to HART Revision 5 or 7 if desired.
- (16) Requires Plantweb housing and output code A. Includes Hardware Adjustments as standard.
- (17) For process connection option code A11, the mounting bracket must be ordered as part of the manifold model number.
- (18) Not available with output code F.
- (19) Not available with output code X.
- (20) Not available with housing style codes 00, 2E, 2F, 2G, 2M, 5A, 5J, or 7J.
- (21) Not available with process connection option code A11.
- (22) Requires Plantweb housing and Hardware Adjustments option code D1. Limited availability depending on transmitter type and range. Contact an Emerson representative for additional information.
- (23) This assembly is included with options EP, KP, E1, N1, K1, ND, E4, E7, N7, K7, E2, E3, KA, KC, KD, IA, IB, IE, IF, IG, KG, T1, K2, N3, EM, and KM.
- (24) Transmitter is shipped with 316 SST conduit plug (uninstalled) in place of standard carbon steel conduit plug.
- (25) Valid when SuperModule Platform and housing have equivalent approvals.
- (26) Not available with M20 or G½ conduit entry size.
- (27) Only available on differential and gage measurement types. Silicone fill fluid is standard.
- (28) Bolts are not considered process wetted. In instances where NACE MR0175/ISO 15156 and NACE MR0103 conformance is required for bolting, L7 is the recommended bolting option.
- (29) Not available with Housing code 7J.
- (30) Not available with output code F, option code DA2, or option code QT.
- (31) See the Rosemount 3051S [Reference Manual](#) for cable requirements. Contact an Emerson representative for additional information.
- (32) P1 is not available with 3051S_CA0.
- (33) When assembled to remote diaphragm seal system using B11 or B12 process connections, the maximum working pressure of the system may be limited by the rating of the Rosemount 1199 Seal System selected.
- (34) Requires 316L SST, Alloy C-276, or Gold-plated 316L SST diaphragm material, assemble to Rosemount 305 integral manifold or DIN-compliant traditional flange process connection, and bolting option L8. Limited to Pressure Range (Differential), ranges 2A – 5A.
- (35) Not available with output code F or X. Not available with housing code 7J.
- (36) Not available with Housing code 00, 5A, 5J, or 7J.
- (37) The T1 option is not needed with FISCO Product Certifications; transient protection is included in the FISCO product certification codes IA, IB, IE, IF, IG, and KG.
- (38) Requires 316L SST diaphragm material, glass-filled PTFE O-ring (standard), and Process Connection code E12 or F12.
- (39) Not available with Housing code 00, 5A, 5J, or 7J. Available with Intrinsically Safe approvals only. For FM Intrinsically Safe; Nonincendive (option code I5) or FM FISCO Intrinsically Safe (option code IE), install in accordance with Rosemount drawing 03151-1009. Suitable for use with all IS approvals (I1, I2, I3, I5, I6, I7, IA, IB, IE, IF, IG, IP, IM, KG).
- (40) NACE compliant wetted materials are identified by footnote ⁽⁵⁾.

Rosemount™ 3051S In-line Pressure Transmitter



Rosemount 3051S In-line Pressure Transmitters are the industry leader for Gage and Absolute pressure measurement. The in-line, compact design allows the transmitter to be connected directly to a process for quick, easy and cost effective installation. Capabilities include:

- Ultra and Classic Performance
- 4–20 mA HART®, WirelessHART®, FOUNDATION™ Fieldbus protocols
- Safety certification (Option code QT)
- Advanced diagnostics (Option code DA2)
- Remote display and Interface (Option code M7, M8, or M9)

Additional information: [Specifications](#), [Rosemount 3051S/3051SFx/3051S-ERS](#), [Dimensional drawings](#)

Specification and selection of product materials, options, or components must be made by the purchaser of the equipment. See [Material selection](#) for more information .

The starred offerings (★) represent the most common options and should be selected for best delivery. The non-starred offerings are subject to additional delivery lead time.

Table 2: Rosemount 3051S Scalable In-line Pressure Transmitter Ordering Information

Model	Transmitter type		
3051S	Scalable pressure transmitter		
Performance class⁽¹⁾			
1	Ultra: 0.025% span accuracy, 200:1 rangedown, 15-yr stability, 15-yr limited warranty		★
2	Classic: 0.035% span accuracy, 150:1 rangedown, 15-yr stability		★
Connection type			
T	In-line		★
Measurement type			
G	Gage		★
A	Absolute		★
Pressure range			
	Gage	Absolute	
1A	-14.7 to 30 psi (-1,01 to 2,06 bar)	0 to 30 psia (2,06 bar)	★
2A	-14.7 to 150 psi (-1,01 to 10,34 bar)	0 to 150 psia (10,34 bar)	★
3A	-14.7 to 800 psi (-1,01 to 55,15 bar)	0 to 800 psia (55,15 bar)	★
4A	-14.7 to 4000 psi (-1,01 to 275,79 bar)	0 to 4000 psia (275,79 bar)	★
5A	-14.7 to 10000 psi (-1,01 to 689,47 bar)	0 to 10000 psia (689,47 bar)	★
Isolating diaphragm⁽²⁾⁽³⁾			
2	316L SST		★
3	Alloy C-276		★
Process connection			
A11 ⁽⁴⁾	Assemble to Rosemount 306 integral manifold		★
B11 ⁽⁴⁾⁽⁵⁾	Assemble to one Rosemount 1199 seal		★
E11	½–14 NPT female		★

Table 2: Rosemount 3051S Scalable In-line Pressure Transmitter Ordering Information (continued)

G11	G½ A DIN 16288 male (range 1–4 only)		★
H11	Coned and threaded, compatible with autoclave type F-250-C (range 5A only)		
F11	Non-threaded instrument flange (I-flange) (range 1–4 only)		
Transmitter output			
A	4–20 mA with digital signal based on HART protocol		★
F ⁽⁶⁾	FOUNDATION Fieldbus protocol		★
X ⁽⁷⁾	Wireless (requires wireless options and wireless Plantweb housing)		★
Housing style		Material	Conduit entry size
00	None (SuperModule spare part, order output code A)	N/A	N/A
1A	Plantweb housing	Aluminum	½–14 NPT
1B	Plantweb housing	Aluminum	M20 x 1.5
1J	Plantweb housing	SST	½–14 NPT
1K	Plantweb housing	SST	M20 x 1.5
5A ⁽⁸⁾	Wireless Plantweb housing	Aluminum	½–14 NPT
5J ⁽⁸⁾	Wireless Plantweb housing	SST	½–14 NPT
2A	Junction box housing	Aluminum	½–14 NPT
2B	Junction box housing	Aluminum	M20 x 1.5
2J	Junction box housing	SST	½–14 NPT
2E	Junction box housing with output for remote display and interface	Aluminum	½–14 NPT
2F	Junction box housing with output for remote display and interface	Aluminum	M20 x 1.5
2M	Junction box housing with output for remote display and interface	SST	½–14 NPT
7J ⁽⁹⁾	Quick Connect (A size mini, 4-pin male termination)	SST	N/A
1C	Plantweb housing	Aluminum	G½
1L	Plantweb housing	SST	G½
2C	Junction box housing	Aluminum	G½
2G	Junction box housing with output for remote display and interface	Aluminum	G½
Wireless options (requires option code X and wireless Plantweb housing)			
Update rate			
WA	User configurable update rate		★
Operating frequency and protocol			
3	2.4 GHz DSSS, IEC 62591 (<i>WirelessHART</i>)		★
Omni-directional wireless antenna			
WJ	Remote antenna		★
WK	External antenna		★
WM	Extended range, external antenna		★

Table 2: Rosemount 3051S Scalable In-line Pressure Transmitter Ordering Information (continued)

WN	High-gain, remote antenna	
SmartPower⁽¹⁰⁾		
1	Adapter for Black Power Module (I.S. Power Module sold separately)	★
Other options (include with selected model number)		
HART revision configuration (requires HART Protocol output code A)⁽¹¹⁾		
HR7	Configured for HART Revision 7	★
Extended product warranty		
WR3	3-year limited warranty	★
WR5	5-year limited warranty	★
Plantweb control functionality		
A01	FOUNDATION Fieldbus advanced control function block suite	★
Diagnostics suite		
D01	FOUNDATION Fieldbus diagnostics suite: Process Intelligence, Plugged Impulse Line diagnostic	★
DA2 ⁽¹²⁾	Advanced HART diagnostics suite: Process Intelligence, Loop Integrity, Plugged Impulse Line diagnostic, Process Alerts, Service Alerts, Variable Log, Event Log	★
Mounting bracket		
B4	Bracket, all SST, 2-in. pipe and panel	★
BE	316SST B4-style bracket with 316SST bolting	★
Software configuration⁽¹³⁾		
C1	Custom software configuration (requires Configuration Data Sheet)	★
Alarm limit⁽¹³⁾⁽¹⁴⁾		
C4	NAMUR alarm and saturation levels, high alarm	★
C5	NAMUR alarm and saturation levels, low alarm	★
C6	Custom alarm and saturation signal levels, high alarm (requires C1 and Configuration Data Sheet)	★
C7	Custom alarm and saturation signal levels, low alarm (requires C1 and Configuration Data Sheet)	★
C8	Low alarm (standard Rosemount alarm and saturation levels)	★
Hardware adjustments⁽¹³⁾⁽¹⁴⁾⁽¹⁵⁾		
D1	Hardware adjustments (zero, span, alarm, security)	★
Custody transfer⁽¹⁶⁾		
D3	Measurement Canada accuracy approval	★
Ground screw⁽¹⁷⁾		
D4	External ground screw assembly	★
Conduit plug⁽¹⁸⁾		
DO	316 SST conduit plug	★
Product certifications⁽¹⁹⁾		
E1	ATEX Flameproof	★
I1	ATEX Intrinsic Safety	★

Table 2: Rosemount 3051S Scalable In-line Pressure Transmitter Ordering Information (continued)

IA	ATEX FISCO Intrinsic Safety (FOUNDATION Fieldbus protocol only)	★
N1	ATEX Type n	★
K1	ATEX Flameproof, Intrinsic Safety, Type n, Dust	★
ND	ATEX Dust	★
E4	TIIS Flameproof	★
I4 ⁽⁸⁾	TIIS Intrinsic Safety	★
E5	FM Explosion-proof, Dust Ignition-proof	★
I5	FM Intrinsically Safe; Nonincendive	★
IE	FM FISCO Intrinsically Safe (FOUNDATION Fieldbus protocol only)	★
K5	FM Explosion-proof, Dust Ignition-proof, Intrinsically Safe, Division 2	★
E6 ⁽²⁰⁾	CSA Explosion-proof, Dust Ignition-proof, Division 2	★
I6	CSA Intrinsically Safe	★
IF	CSA FISCO Intrinsically Safe (FOUNDATION Fieldbus protocol only)	★
K6 ⁽²⁰⁾	CSA Explosion-proof, Dust Ignition-proof, Intrinsically Safe, Division 2	★
E7	IECEx Flameproof, Dust Ignition-proof	★
I7	IECEx Intrinsic Safety	★
IG	IECEx FISCO Intrinsic Safety (FOUNDATION Fieldbus protocol only)	★
N7	IECEx Type n	★
K7	IECEx Flameproof, Dust Ignition-proof, Intrinsic Safety, Type n	★
E2	INMETRO Flameproof	★
I2	INMETRO Intrinsic Safety	★
IB	INMETRO FISCO Intrinsic Safety	★
K2	INMETRO Flameproof, Intrinsic Safety	★
E3	China Flameproof	★
I3	China Intrinsic Safety	★
N3	China Type n	★
EP	Korea Flameproof	★
IP	Korea Intrinsic Safety	★
KP	Korea Flameproof, Intrinsic Safety	★
EM	Technical Regulations Customs Union (EAC) Flameproof	★
IM	Technical Regulations Customs Union (EAC) Intrinsic Safety	★
KM	Technical Regulations Customs Union (EAC) Flameproof, Intrinsic Safety	★
KA ⁽²⁰⁾	ATEX and CSA Flameproof, Intrinsically Safe, Division 2	★
KB ⁽²⁰⁾	FM and CSA Explosion-proof, Dust Ignition-proof, Intrinsically Safe, Division 2	★
KC	FM and ATEX Explosion-proof, Intrinsically Safe, Division 2	★
KD ⁽²⁰⁾	FM, CSA, and ATEX Explosion-proof, Intrinsically Safe	★
KG	FM, CSA, ATEX and IECEx FISCO Intrinsic Safety	★
KQ	USA, Canada, ATEX Intrinsic Safety Combination	★

Table 2: Rosemount 3051S Scalable In-line Pressure Transmitter Ordering Information (continued)

KS	USA, Canada, IECEx, ATEX Explosion Proof, Intrinsically Safe, Dust, Non-Incendive, Type-N, Division 2	★
Shipboard approvals		
SBS	American Bureau of Shipping	★
SBV	Bureau Veritas (BV) Type Approval	★
SDN	Det Norske Veritas (DNV) Type Approval	★
SLL	Lloyds Register (LR) Type Approval	★
Stainless steel tagging		
Y2	316SST nameplate, top tag, wire-on tag, and fasteners	★
Sensor fill fluid⁽²¹⁾		
L1	Inert sensor fill fluid	★
Display type⁽²²⁾		
M5	Plantweb LCD display	★
M7 ⁽¹⁴⁾⁽²³⁾⁽²⁴⁾	Remote mount LCD display and interface, Plantweb housing, no cable, SST bracket	★
M8 ⁽¹⁴⁾⁽²³⁾⁽²⁴⁾	Remote mount LCD display and interface, Plantweb housing, 50 feet (15 m) cable, SST bracket	★
M9 ⁽¹⁴⁾⁽²³⁾⁽²⁴⁾	Remote mount LCD display and interface, Plantweb housing, 100 feet (31 m) cable, SST bracket	★
Pressure testing		
P1	Hydrostatic testing with certificate	
Special cleaning⁽²⁵⁾		
P2	Cleaning for special services	
P3	Cleaning for special services with testing for <1PPM chlorine/fluorine	
Calibration certification		
Q4	Calibration certificate	★
QP	Calibration certificate and tamper evident seal	★
Material traceability certification		
Q8	Material traceability certification per EN 10204 3.1	★
Quality certification for safety⁽²⁶⁾		
QS	Prior-use certificate of FMEDA data	★
QT	Safety-certified to IEC 61508 with certificate of FMEDA data	★
Transient protection⁽²⁷⁾⁽²⁸⁾		
T1	Transient terminal block	★
Drinking water approval⁽²⁹⁾		
DW	NSF drinking water approval	★
Surface finish certification		
Q16	Surface finish certification for sanitary remote seals	★
Toolkit total system performance reports		
QZ	Remote seal system performance calculation report	★
Conduit electrical connector⁽³⁰⁾		
GE	M12, 4-pin, male connector (eurofast®)	★

Table 2: Rosemount 3051S Scalable In-line Pressure Transmitter Ordering Information (continued)

GM	A size mini, 4-pin, male connector (minifast [®])	★
NACE certificate⁽³¹⁾		
Q15	Certificate of compliance to NACE MR0175/ISO 15156 for wetted materials	★
Q25	Certificate of compliance to NACE MR0103 for wetted materials	★
Typical model number: 3051S1TG 2A 2 E11 A 1A DA2 B4 M5		

- (1) For details, see [Specifications](#).
- (2) Materials of Construction comply with metallurgical requirements highlighted within NACE MR0175/ISO 15156 for sour oil field production environments. Environmental limits apply to certain materials. Consult latest standard for details. Selected materials also conform to NACE MR0103 for sour refining environments. Order with Q15 or Q25 to receive a NACE certificate.
- (3) Isolator diaphragm selection will dictate materials of construction for wetted parts.
- (4) "Assemble to" items are specified separately and require a completed model number.
- (5) Consult an Emerson representative for performance specifications.
- (6) Requires Plantweb housing.
- (7) Only intrinsically safe approval codes apply.
- (8) Only available with output code X.
- (9) Only available with output code A. Available approvals are FM Intrinsically Safe; Nonincendive (option code I5), CSA Intrinsically Safe (option code I6), ATEX Intrinsic Safety (option code I1), or IECEx Intrinsic Safety (option code I7). Contact an Emerson representative for additional information.
- (10) Long-Life Power Module must be shipped separately, order Power Module 701PBKKF.
- (11) Option HR7 configures the HART output to HART Revision 7. This option requires the selection of the Advanced Diagnostics (DA2) option. The device with this option can be field configured to HART Revision 5 or 7 if desired.
- (12) Requires Plantweb housing and output code A. Includes Hardware Adjustments as standard.
- (13) Not available with output code F.
- (14) Not available with output code X.
- (15) Not available with housing style codes 00, 01, 2E, 2F, 2G, 2M, 5A, 5J, or 7J.
- (16) Requires Plantweb housing and Hardware Adjustments option code D1. Limited availability depending on transmitter type and range. Contact an Emerson representative for additional information.
- (17) This assembly is included with options EP, KP, E1, N1, K1, ND, E4, E7, N7, K7, E2, E3, KA, KC, KD, IA, IB, IE, IF, IG, KG, T1, K2, N3, EM, and KM.
- (18) Transmitter is shipped with 316 SST conduit plug (uninstalled) in place of standard carbon steel conduit plug.
- (19) Valid when SuperModule Platform and housing have equivalent approvals.
- (20) Not available with M20 or G½ conduit entry size.
- (21) Silicone fill fluid is standard.
- (22) Not available with Housing code 7J.
- (23) Not available with output code F, option code DA2, or option code QT.
- (24) See the Rosemount 3051S [Reference Manual](#) for cable requirements. Contact an Emerson representative for additional information.
- (25) Not available with process connection option code A11.
- (26) Not available with output code F or X. Not available with housing code 7J.
- (27) Not available with Housing code 00, 5A, 5J, or 7J.
- (28) The T1 option is not needed with FISCO Product Certifications; transient protection is included in the FISCO product certification codes IA, IB, IE, IF, IG, and KG.
- (29) Requires 316L SST diaphragm material and Process Connection code E11 or G11.
- (30) Not available with Housing code 00, 5A, 5J, or 7J. Available with Intrinsically Safe approvals only. For FM Intrinsically Safe; Nonincendive (option code I5) or FM FISCO Intrinsically Safe (option code IE), install in accordance with Rosemount drawing 03151-1009. Suitable for use with all IS approvals (I1, I2, I3, I5, I6, I7, IA, IB, IE, IF, IG, IP, IM, KG).
- (31) NACE compliant wetted materials are identified by footnote ⁽²⁾.

Rosemount 3051S MultiVariable Transmitter



The Rosemount™ 3051S MultiVariable™ Transmitter delivers unprecedented performance and capabilities by providing superior flow calculations including fully compensated mass or volume, energy, and totalized flow. Specify the level of compensation that best matches the application:

- Gas, natural gas, and steam measurement: Utilize full compensation (differential pressure, line pressure, and temperature measurement)
- Saturated steam: Utilize differential and line pressure, or differential pressure and temperature measurement
- Liquids: Utilize differential pressure and temperature measurement
- Liquids at stable temperatures: Utilize differential pressure measurement
- 4–20 mA HART®, WirelessHART®, FOUNDATION™ Fieldbus protocols

Additional information: [Specifications](#), [Rosemount 3051SMV/3051SFx](#), [Dimensional drawings](#)

Specification and selection of product materials, options, or components must be made by the purchaser of the equipment. See [Material selection](#) for more information.

The starred offerings (★) represent the most common options and should be selected for best delivery. The non-starred offerings are subject to additional delivery lead time.

Table 3: Rosemount 3051S Scalable™ MultiVariable Transmitter Ordering Information

Model	Transmitter type	
3051SMV	Scalable multivariable transmitter	
Performance class⁽¹⁾		
Measurement types 1 and 2		
3 ⁽²⁾	Ultra for Flow: 0.04% reading DP accuracy, 200:1 rangedown, 15-year stability, 15-year limited warranty	★
5	Classic MV: 0.04% span DP accuracy, 100:1 rangedown, 15-year stability	★
Measurement types 3 and 4		
1	Ultra: 0.025% span DP accuracy, 200:1 rangedown, 15-year stability, 15-year limited warranty	★
2	Classic: 0.035% span DP accuracy, 150:1 rangedown, 15-year stability	★
3 ⁽²⁾	Ultra for Flow: 0.04% reading DP accuracy, 200:1 rangedown, 15-year stability, 15-year limited warranty	★
Multivariable type		
M	Measurement with fully compensated mass and energy ⁽³⁾ flow calculations	★
P	Measurement of process variables only (no flow calculations)	★
Measurement type		
1	Differential pressure, static pressure, and temperature	★
2	Differential pressure and static pressure	★
3	Differential pressure and temperature	★
4	Differential pressure	★
Differential pressure range⁽⁴⁾		
0 ⁽⁵⁾	–3 to 3 inH ₂ O (–7,46 to 7,46 mbar)	★
1	–25 to 25 inH ₂ O (–62,16 to 62,16 mbar)	★
2	–250 to 250 inH ₂ O (–621,60 to 621,60 mbar)	★
3	–1000 to 1000 inH ₂ O (–2,48 to 2,48 bar)	★

Table 3: Rosemount 3051S Scalable™ MultiVariable Transmitter Ordering Information (continued)

4 ⁽⁶⁾	–150 to 150 psi (–10,34 to 10,34 bar) for measurement types 1 and 2; –300 to 300 psi (–20,68 to 20,68 bar) for measurement types 3 and 4				★	
5 ⁽⁶⁾	–2000 to 2000 psi (–137,89 to 137,89 bar)				★	
Static pressure type						
N ⁽⁷⁾	None				★	
A	Absolute				★	
G	Gage				★	
Static pressure range		Absolute	Gage			
N ⁽⁷⁾	None	N/A	N/A		★	
3	Range 3	0.5 to 800 psia (0,03 to 55,15 bar)	–14.2 to 800 psig (–0,98 to 55,15 bar)		★	
4 ⁽⁸⁾	Range 4	0.5 to 3626 psia (0,03 to 250,00 bar)	–14.2 to 3626 psig (–0,98 to 250,00 bar)		★	
Temperature input						
N ⁽⁹⁾	None				★	
R ⁽¹⁰⁾	RTD input (type Pt 100, –328 to 1562 °F [–200 to 850 °C])				★	
Isolating diaphragm						
2 ⁽¹¹⁾	316L SST				★	
3 ⁽¹¹⁾	Alloy C-276				★	
5 ⁽¹²⁾	Tantalum					
7 ⁽¹¹⁾	Gold-plated 316L SST					
Process connection		Size	Material type			
			Flange material	Drain vent	Bolting	
000	None (no process flange)	N/A	N/A	N/A	N/A	★
A11 ⁽¹³⁾	Assemble to Rosemount 305/306 integral manifold	N/A	N/A	N/A	N/A	★
A12 ⁽¹³⁾	Assemble to Rosemount 304 or AMF manifold with SST traditional flange	N/A	N/A	N/A	N/A	★
A15 ⁽¹³⁾	Assemble to Rosemount 304 or AMF manifold to SST traditional flange with Alloy C-276 drain vents	N/A	N/A	N/A	N/A	★
A16 ⁽¹³⁾	Assemble to Rosemount 304 or AMF manifold to DIN SST traditional flange	N/A	N/A	N/A	N/A	★
A22	Assemble to Rosemount 304 or AMF manifold to SST coplanar flange	N/A	N/A	N/A	N/A	★
B11 ⁽¹³⁾⁽¹⁴⁾	Assemble to one Rosemount 1199 seal	N/A	N/A	N/A	N/A	★
B12 ⁽¹³⁾⁽¹⁴⁾	Assemble to two Rosemount 1199 seals	N/A	N/A	N/A	N/A	★

Table 3: Rosemount 3051S Scalable™ MultiVariable Transmitter Ordering Information (continued)

C11 ⁽¹³⁾	Assemble to Rosemount 405C or 405P primary element	N/A	N/A	N/A	N/A	★
D11 ⁽¹³⁾	Assemble to Rosemount 1195 integral orifice and Rosemount 305 integral manifold	N/A	N/A	N/A	N/A	★
EA2 ⁽¹³⁾	Assemble to Rosemount 485 or 405A Annubar primary element with coplanar flange	N/A	SST	316 SST	N/A	★
EA3 ⁽¹³⁾	Assemble to Rosemount 485 or 405A Annubar primary element with coplanar flange	N/A	Cast C-276	Alloy C-276	N/A	★
EA5 ⁽¹³⁾	Assemble to Rosemount 485 or 405A Annubar primary element with coplanar flange	N/A	SST	Alloy C-276	N/A	★
E11	Coplanar flange	¼–18 NPT	Carbon steel	316 SST	N/A	★
E12	Coplanar flange	¼–18 NPT	SST	316 SST	N/A	★
E13 ⁽¹¹⁾	Coplanar flange	¼–18 NPT	Cast C-276	Alloy C-276	N/A	★
E14	Coplanar flange	¼–18 NPT	Cast Alloy 400	Alloy 400/K-500	N/A	★
E15 ⁽¹¹⁾	Coplanar flange	¼–18 NPT	SST	Alloy C-276	N/A	★
E16 ⁽¹¹⁾	Coplanar flange	¼–18 NPT	Carbon steel	Alloy C-276	N/A	★
E21	Coplanar flange	RC ¼	Carbon steel	316 SST	N/A	★
E22	Coplanar flange	RC ¼	SST	316 SST	N/A	★
E23 ⁽¹¹⁾	Coplanar flange	RC ¼	Cast C-276	Alloy C-276	N/A	★
E24	Coplanar flange	RC ¼	Cast Alloy 400	Alloy 400/K-500	N/A	★
E25 ⁽¹¹⁾	Coplanar flange	RC ¼	SST	Alloy C-276	N/A	★
E26 ⁽¹¹⁾	Coplanar flange	RC ¼	Carbon steel	Alloy C-276	N/A	★
F12	Traditional flange	¼–18 NPT	SST	316 SST	N/A	★
F13 ⁽¹¹⁾	Traditional flange	¼–18 NPT	Cast C-276	Alloy C-276	N/A	★
F14	Traditional flange	¼–18 NPT	Cast Alloy 400	Alloy 400/K-500	N/A	★
F15 ⁽¹¹⁾	Traditional flange	¼–18 NPT	SST	Alloy C-276	N/A	★
F22	Traditional flange	RC ¼	SST	316 SST	N/A	★
F23 ⁽¹¹⁾	Traditional flange	RC ¼	Cast C-276	Alloy C-276	N/A	★
F24	Traditional flange	RC ¼	Cast Alloy 400	Alloy 400/K-500	N/A	★
F25 ⁽¹¹⁾	Traditional flange	RC ¼	SST	Alloy C-276	N/A	★
F52	DIN-compliant traditional flange	¼–18 NPT	SST	316 SST	7/16-in. bolting	★
G11	Vertical mount level flange	2-in. ANSI Class 150	SST	N/A	N/A	★
G12	Vertical mount level flange	2-in. ANSI Class 300	SST	N/A	N/A	★
G14 ⁽¹¹⁾	Vertical mount level flange	2-in. ANSI Class 150	Cast C-276	N/A	N/A	★
G15 ⁽¹¹⁾	Vertical mount level flange	2-in. ANSI Class 300	Cast C-276	N/A	N/A	★
G21	Vertical mount level flange	3-in. ANSI Class 150	SST	N/A	N/A	★

Table 3: Rosemount 3051S Scalable™ MultiVariable Transmitter Ordering Information (continued)

G22	Vertical mount level flange	3-in. ANSI Class 300	SST	N/A	N/A	★
G31	Vertical mount level flange	DIN- DN 50 PN 40	SST	N/A	N/A	★
F32	Bottom vent traditional flange	¼–18 NPT	SST	316 SST	N/A	
F42	Bottom vent traditional flange	RC ¼	SST	316 SST	N/A	
F62	DIN-compliant traditional flange	¼–18 NPT	SST	316 SST	M10 bolting	
F72	DIN-compliant traditional flange	¼–18 NPT	SST	316 SST	M12 bolting	
G41	Vertical mount level flange	DIN- DN 80 PN 40	SST	N/A	N/A	
Transmitter output						
A	4–20 mA with digital signal based on HART protocol					★
X ⁽¹⁵⁾	Wireless (requires wireless options and wireless Plantweb housing)					★
F ⁽¹⁶⁾	FOUNDATION Fieldbus					★
Housing style			Material	Conduit entry size		
1A	Plantweb housing		Aluminum	½–14 NPT		★
1B	Plantweb housing		Aluminum	M20 x 1.5		★
1J	Plantweb housing		SST	½–14 NPT		★
1K	Plantweb housing		SST	M20 x 1.5		★
5A ⁽¹⁷⁾	Wireless Plantweb housing		Aluminum	½–14 NPT		★
5J ⁽¹⁷⁾	Wireless Plantweb housing		SST	½–14 NPT		★
1C	Plantweb housing		Aluminum	G½		
1L	Plantweb housing		SST	G½		
Wireless options (requires option code X and wireless Plantweb housing)						
Update rate						
WA	User configurable update rate					★
Operating frequency and protocol						
3	2.4 GHz DSSS, IEC 62591 (<i>WirelessHART</i>)					★
Omni-directional wireless antenna						
WK	External antenna					★
WM	Extended range, external antenna					★
WN	High-gain, remote antenna					★
SmartPower™⁽¹⁸⁾						
1	Adapter for Black Power Module (I.S. Power Module sold separately)					★
Other options (include with selected model number)						
Extended product warranty						
WR3	3-year limited warranty					★
WR5	5-year limited warranty					★

Table 3: Rosemount 3051S Scalable™ MultiVariable Transmitter Ordering Information (continued)

RTD cable (RTD sensor must be ordered separately)		
C12	RTD input with 12 feet (3,66 m) of shielded cable	★
C13	RTD input with 24 feet (7,32 m) of shielded cable	★
C14	RTD input with 75 feet (22,86 m) of shielded cable	★
C22	RTD input with 12 feet (3,66 m) of armored shielded cable	★
C23	RTD input with 24 feet (7,32 m) of armored shielded cable	★
C24	RTD input with 75 feet (22,86 m) of armored shielded cable	★
C32	RTD input with 12 feet (3,66 m) of ATEX/IECEX Flameproof cable	★
C33	RTD input with 24 feet (7,32 m) of ATEX/IECEX Flameproof cable	★
C34	RTD input with 75 feet (22,86 m) of ATEX/IECEX Flameproof cable	★
Plantweb control functionality		
A01	FOUNDATION Fieldbus advanced control function block suite	★
Mounting brackets⁽¹⁹⁾		
B4	Coplanar flange bracket, all SST, 2-in. pipe and panel	★
B1	Traditional flange bracket, carbon steel, 2-in. pipe	★
B2	Traditional flange bracket, carbon steel, panel	★
B3	Traditional flange flat bracket, carbon steel, 2-in. pipe	★
B7	Traditional flange bracket, B1 with SST bolts	★
B8	Traditional flange bracket, B2 with SST bolts	★
B9	Traditional flange bracket, B3 with SST bolts	★
BA	Traditional flange bracket, B1, all SST	★
BC	Traditional flange bracket, B3, all SST	★
BE	316SST B4-style bracket with 316SST bolting	★
Software configuration		
C1 ⁽²⁰⁾	Custom software configuration (Rosemount 3051SMV Configuration Data Sheet must be completed.)	★
C2 ⁽²¹⁾	Custom flow configuration (Rosemount 3051SMV Wireless Configuration Data Sheet must be completed for WirelessHART devices, Rosemount 3051SMV Configuration Data Sheet for HART devices, and Rosemount 3051SMV Configuration Data Sheet for Fieldbus devices.)	★
Alarm limits⁽²⁰⁾⁽²¹⁾		
C4	NAMUR alarm and saturation levels, high alarm	★
C5	NAMUR alarm and saturation levels, low alarm	★
C6	Custom alarm and saturation signal levels, high alarm	★
C7	Custom alarm and saturation signal levels, low alarm	★
C8	Low alarm (standard Rosemount alarm and saturation levels)	★
Flange adapter⁽²²⁾		
D2	½–14 NPT flange adapter	★
D9	RC ½ SST flange adapter	
Ground screw⁽²³⁾		
D4	External ground screw assembly	★

Table 3: Rosemount 3051S Scalable™ MultiVariable Transmitter Ordering Information (continued)

Drain/vent valve⁽²²⁾		
D5	Delete transmitter drain/vent valves (install plugs)	★
D7	Coplanar flange without drain/vent ports	
Conduit plug⁽²⁴⁾		
DO	316 SST conduit plug	★
Product certifications		
E1	ATEX Flameproof	★
I1	ATEX Intrinsic Safety	★
IA ⁽²⁵⁾	ATEX FISCO Intrinsic Safety	★
N1	ATEX Type n	★
ND	ATEX Dust	★
K1	ATEX Flameproof, Intrinsic Safety, Type n, Dust (combination of E1, I1, N1, and ND)	★
E4	TIIS Flameproof	★
E5	FM Explosion-proof, Dust Ignition-proof	★
I5	FM Intrinsically Safe; Nonincendive	★
IE ⁽²⁵⁾	FM FISCO Intrinsic Safety	★
K5	FM Explosion-proof, Dust Ignition-proof, Intrinsically Safe, Division 2 (combination of E5 and I5)	★
E6 ⁽²⁶⁾	CSA Explosion-proof, Dust Ignition-proof, Division 2	★
I6	CSA Intrinsically Safe	★
IF ⁽²⁵⁾	CSA FISCO Intrinsic Safety	★
K6 ⁽²⁶⁾	CSA Explosion-proof, Dust Ignition-proof, Intrinsically Safe, Division 2 (combination of E6 and I6)	★
E7	IECEX Flameproof, Dust Ignition-proof	★
I7	IECEX Intrinsic Safety	★
IG ⁽²⁵⁾	IECEX FISCO Intrinsic Safety	★
N7	IECEX Type n	★
K7	IECEX Flameproof, Dust Ignition-proof, Intrinsic Safety, and Type n (combination of E7, I7, and N7)	★
E2	INMETRO Flameproof	★
I2	INMETRO Intrinsic Safety	★
E3	China Flameproof	★
I3	China Intrinsic Safety	★
EM	Technical Regulations Customs Union (EAC) Flameproof	★
IM	Technical Regulations Customs Union (EAC) Intrinsic Safety	★
KM	Technical Regulations Customs Union (EAC) Flameproof, Intrinsic Safety	★
KA ⁽²⁶⁾⁽²⁷⁾	ATEX and CSA Explosion-proof, Intrinsically Safe, Division 2 (combination of E1, E6, I1, and I6)	★
KB ⁽²⁶⁾⁽²⁷⁾	FM and CSA Explosion-proof, Dust Ignition-proof, Intrinsically Safe, Division 2 (combination of E5, E6, I5, and I6)	★
KC	FM and ATEX Explosion-proof, Intrinsically Safe, Division 2 (combination of E5, E1, I5, and I1)	★
KD ⁽²⁶⁾⁽²⁷⁾	FM, CSA, and ATEX Explosion-proof, Intrinsically Safe (combination of E5, E6, E1, I5, I6, and I1)	★
KG ⁽²⁵⁾	ATEX, FM, CSA, and IECEX FISCO Intrinsic Safety (combination of IA, IE, IF, and IG)	★

Table 3: Rosemount 3051S Scalable™ MultiVariable Transmitter Ordering Information (continued)

K2	INMETRO Flameproof, Intrinsic Safety (Combination of E2 and I2)	★
EP	Korea Flameproof	★
IP	Korea Intrinsic Safety	★
KP	Korea Flameproof, Intrinsic Safety	★
KS	USA, Canada, IECEx, ATEX Explosion Proof, Intrinsically Safe, Dust, Non-Incendive, Type-N, Division 2	★
Drinking water approval⁽²⁸⁾		
DW	NSF drinking water certification	★
Shipboard approvals⁽²⁰⁾		
SBS	American Bureau of Shipping	★
SBV	Bureau Veritas (BV) Type Approval	★
SDN	Det Norske Veritas (DNV) Type Approval	★
SLL	Lloyds Register (LR) Type Approvals	★
Stainless steel tagging		
Y2	316SST nameplate, top tag, wire-on tag, and fasteners	★
Sensor fill fluid⁽²⁹⁾		
L1	Inert sensor fill fluid (differential and gage sensors only)	★
O-rings		
L2	Graphite-filled PTFE O-ring	★
Bolting material		
L4 ⁽²²⁾	Austenitic 316 SST bolts	★
L5 ⁽²²⁾	ASTM A193, Grade B7M bolts	★
L6 ⁽²²⁾	Alloy K-500 bolts	★
L7 ⁽²²⁾⁽³⁰⁾	ASTM A453, Class D, Grade 660 bolts	★
L8 ⁽²²⁾	ASTM A193, Class 2, Grade B8M bolts	★
Digital display		
M5	Plantweb LCD display	★
Wireless assembly options⁽³⁾		
WTA	Integral assembly to Emerson Wireless THUM™ Adapter (specified separately)	★
Pressure testing		
P1 ⁽³¹⁾	Hydrostatic testing with certificate	★
Maximum static line pressure		
p9 ⁽³²⁾⁽³³⁾	4500 psig (310 bar) static pressure limit	★
p0 ⁽³²⁾⁽³⁴⁾	6092 psig (420 bar) static pressure limit	★
Special cleaning		
P2 ⁽²²⁾	Cleaning for special services	
P3 ⁽²²⁾	Cleaning for special services with testing for <1PPM chlorine/fluorine	
Calibration certification		
Q4	Calibration certificate	★

Table 3: Rosemount 3051S Scalable™ MultiVariable Transmitter Ordering Information (continued)

QP	Calibration certificate and tamper evident seal	★
Material traceability certification		
Q8	Material traceability certification per EN 10204 3.1B	★
Surface finish certification		
Q16	Surface finish certification for sanitary remote seals	★
Toolkit total system performance reports		
QZ	Remote seal system performance calculation report	★
Quality certification for safety⁽³⁵⁾		
QS	Prior-use certification of FMEDA data	★
QT	Safety certified to IEC 61508 with certification of FMEDA data	★
Transient protection⁽³⁶⁾		
T1	Transient terminal block	★
Conduit electrical connector⁽³⁷⁾		
GE	M12, 4-pin, male connector (eurofast®)	★
GM	A size mini, 4-pin, male connector (minifast®)	★
NACE certificate⁽³⁸⁾		
Q15	Certificate of compliance to NACE MR0175/ISO 15156 for wetted materials	★
Q25	Certificate of compliance to NACE MR0103 for wetted materials	★
Cold temperature⁽²⁰⁾		
BRR	-58 °F (-50 °C) cold temperature start-up	★
Typical model number: 3051SMV 3 M 1 2 G 4 R 2 E12 A 1A B4 C2 M5		

- (1) For details, see [Specifications](#).
- (2) For Measurement Types 1 and 2, only available with DP range codes 2, 3, and 4, 316L SST and Alloy C-276 isolating diaphragm and silicone fill fluid. For Measurements Types 3 and 4, only available with DP range codes 2 and 3, 316L SST and Alloy C-276 isolating diaphragm and silicone fill fluid.
- (3) Only available with Transmitter output code A.
- (4) If ordering measurement type code M, DP Range 4 and 5 are not available.
- (5) DP Range 0 is only available with Measurement Type 3 or 4 and traditional flange, 316L SST diaphragm material, and Bolting option L4.
- (6) DP Range 4 and 5 is only available with SP range N or 4 and Alloy C-276 diaphragm material.
- (7) Required for Measurement Type codes 3 and 4.
- (8) For Measurement Type codes 1 and 2 with DP range 1, absolute limits are 0.5 to 2000 psi (0,03 to 137,9 bar) and gage limits are -14.2 to 2000 psig (-0,98 to 137,9 bar).
- (9) Required for Measurement Type codes 2 and 4.
- (10) Required for Measurement Type codes 1 and 3. RTD Sensor must be ordered separately.
- (11) Materials of Construction comply with metallurgical requirements highlighted within NACE® MR0175/ISO 15156 for sour oil field production environments Environmental limits apply to certain materials. Consult latest standard for details. Selected materials also conform to NACE MR0103 for sour refining environments. Order with Q15 or Q25 to receive a NACE certificate.
- (12) Tantalum diaphragm material is only available for DP ranges 2-5.
- (13) "Assemble to" items are specified separately and require a completed model number.
- (14) Consult an Emerson™ representative for performance specifications.
- (15) Only available with Measurement Type 2 and multivariable type P.
- (16) Transmitter output code F is not available with Performance Class 1 and 2 and Measurement Type 3 and 4.
- (17) Only available with output code X.
- (18) Long-Life Power Module must be shipped separately, order Power Module 701PBKKF.
- (19) For process connection option code A11, the mounting bracket must be ordered as part of the manifold model number.

- (20) Not available with transmitter output code F.
- (21) Not available with transmitter output code X.
- (22) Not available with process connection option code A11.
- (23) This assembly is included with certification options EP, KP, E1, N1, K1, ND, E4, E7, N7, K7, E2, E3, KA, KC, KD, EM, KM, IA, IE, IF, IG, KG.
- (24) Transmitter is shipped with 316 SST conduit plug (uninstalled) in place of standard carbon steel conduit plug.
- (25) FISCO is only available with transmitter output code F.
- (26) Not available with M20 or G½ conduit entry size.
- (27) RTD cable not available with this option.
- (28) Requires 316L SST diaphragm material, glass-filled PTFE O-ring (standard), and Process Connection code E12 or F12.
- (29) Silicone fill fluid is standard.
- (30) Bolts are not considered process wetted. In instances where NACE MR0175/ISO 15156 and NACE MR0103 conformance is required for bolting, L7 is the recommended bolting option.
- (31) Not available with DP range 0.
- (32) Only available with Measurement Type codes 3 and 4.
- (33) When assembled to remote diaphragm seal system using B11 or B12 process connections, the maximum working pressure of the system may be limited by the rating of the Rosemount 1199 Seal System selected.
- (34) Requires 316L SST or Alloy C-276 diaphragm material, assemble to Rosemount 305 Integral Manifold or DIN-compliant traditional flange process connection, and bolting option L8. Limited to differential pressure ranges 2-5.
- (35) Not available with output code F or X.
- (36) The T1 option is not needed with FISCO Product Certifications; transient protection is included in the FISCO product certification codes IA, IB, IE, IF, IG, and KG.
- (37) Available with Intrinsically Safe approvals only. For FM Intrinsically Safe; Nonincendive approval (option code I5), install in accordance with Rosemount drawing 03151-1009.
- (38) NACE compliant wetted materials are identified by footnote ⁽¹⁾.

Rosemount™ 3051SF DP Flow Meters

Rosemount 3051SF Flow Meters integrate the Rosemount 3051S with industry leading primary elements. Capabilities include:

- Flow meters are factory configured to meet your application needs (Configuration Data Sheet required)
- Multivariable capabilities allow scalable flow compensation (Measurement Types 1–4)
- 4–20 mA HART®, WirelessHART®, and FOUNDATION™ Fieldbus protocols
- Ultra for Flow for improved flow performance across wider flow ranges
- Integral temperature measurement (Option code T)
- Advanced diagnostics (Option code DA2)
- Direct or remote mount configurations available

Additional information: [Specifications](#), [Rosemount 3051S/3051SFx/3051S-ERS](#), [Dimensional drawings](#)

Rosemount 3051SFA Annubar Flow Meter



- Annubar flow meters reduce permanent pressure loss by creating less blockage in the pipe
- Ideal for large line size installations when cost, size and weight of the flow meter are concerns

Specification and selection of product materials, options, or components must be made by the purchaser of the equipment. See [Material selection](#) for more information.

For additional technical data and ordering information for Rosemount Annubar Primary Elements, refer to the Rosemount DP Flow meters and Primary Elements [Product Data Sheet](#).

The starred offerings (★) represent the most common options and should be selected for best delivery. The non-starred offerings are subject to additional delivery lead time.

Table 4: Rosemount 3051SFA Annubar Flow Meter Ordering Information

• = Available — = Unavailable				
Model	Product description	Measurement type		
		D	1-7	
3051SFA	Annubar flow meter	•	•	
Measurement type				
1	Fully compensated mass and energy ⁽¹⁾ flow calculations – differential and static pressures with temperature	—	•	★
2	Compensated flow calculations – differential and static pressures	—	•	★
3	Compensated flow calculations – differential pressure and temperature	—	•	★
4	Compensated flow calculations – differential pressure	—	•	★
D	Differential pressure	•	—	★
5	Process variables only (no flow calculations) – differential and static pressures with temperature	—	•	★
6	Process variables only (no flow calculations) – differential and static pressures	—	•	★
7	Process variables only (no flow calculations) – differential pressure and temperature	—	•	★
Fluid type				
L	Liquid	•	•	★

Table 4: Rosemount 3051SFA Annubar Flow Meter Ordering Information (continued)

G	Gas	•	•	★
S	Steam	•	•	★
Line size				
020	2-in. (50 mm)	•	•	★
025	2½-in. (63,5 mm)	•	•	★
030	3-in. (80 mm)	•	•	★
035	3½-in. (89 mm)	•	•	★
040	4-in. (100 mm)	•	•	★
050	5-in. (125 mm)	•	•	★
060	6-in. (150 mm)	•	•	★
070	7-in. (175 mm)	•	•	★
080	8-in. (200 mm)	•	•	★
100	10-in. (250 mm)	•	•	★
120	12-in. (300 mm)	•	•	★
140	14-in. (350 mm)	•	•	
160	16-in. (400 mm)	•	•	
180	18-in. (450 mm)	•	•	
200	20-in. (500 mm)	•	•	
240	24-in. (600 mm)	•	•	
300	30-in. (750 mm)	•	•	
360	36-in. (900 mm)	•	•	
420	42-in. (1066 mm)	•	•	
480	48-in. (1210 mm)	•	•	
600	60-in. (1520 mm)	•	•	
720	72-in. (1820 mm)	•	•	
780	78-in. (1950 mm)	•	•	
840	84-in. (2100 mm)	•	•	
900	90-in. (2250 mm)	•	•	
960	96-in. (2400 mm)	•	•	
Pipe I.D. range⁽²⁾				
C	Range C from the Pipe I.D. table	•	•	★
D	Range D from the Pipe I.D. table	•	•	★
A	Range A from the Pipe I.D. table	•	•	
B	Range B from the Pipe I.D. table	•	•	
E	Range E from the Pipe I.D. table	•	•	
Z	Non-standard Pipe I.D. Range or line sizes greater than 12-in. (300 mm)	•	•	
Pipe material/mounting assembly material				
C	Carbon steel (A105)	•	•	★

Table 4: Rosemount 3051SFA Annubar Flow Meter Ordering Information (continued)

S	316 stainless steel	•	•	★
0 ⁽³⁾	No mounting (customer supplied)	•	•	★
G	Chrome-Moly Grade F-11	•	•	
N	Chrome-Moly Grade F-22	•	•	
J	Chrome-Moly Grade F-91	•	•	
Piping orientation				
H	Horizontal piping	•	•	★
D	Vertical piping with downwards flow	•	•	★
U	Vertical piping with upwards flow	•	•	★
Annubar type				
P	Pak-Lok	•	•	★
F	Flanged with opposite side support	•	•	★
L	Flange-Lok	•	•	
G	Gear-Drive Flo-Tap	•	•	
M	Manual Flo-Tap	•	•	
Sensor material				
S	316 Stainless steel	•	•	★
H	Alloy C-276	•	•	
Sensor size				
1	Sensor size 1 — Line sizes 2-in. (50 mm) to 8-in. (200 mm)	•	•	★
2	Sensor size 2 — Line sizes 6-in. (150 mm) to 96-in. (2400 mm)	•	•	★
3	Sensor size 3 — Line sizes greater than 12-in. (300 mm)	•	•	★
Mounting type				
T1	Compression/threaded connection	•	•	★
A1	Class 150 RF ANSI	•	•	★
A3	Class 300 RF ANSI	•	•	★
A6	Class 600 RF ANSI	•	•	★
D1	DN PN16 flange	•	•	★
D3	DN PN40 flange	•	•	★
D6	DN PN100 flange	•	•	★
A9 ⁽⁴⁾	Class 900 RF ANSI	•	•	
AF ⁽⁴⁾	Class 1500 RF ANSI	•	•	
AT ⁽⁴⁾	Class 2500 RF ANSI	•	•	
R1	Class 150 RTJ flange	•	•	
R3	Class 300 RTJ flange	•	•	
R6	Class 600 RTJ flange	•	•	
R9 ⁽⁴⁾	Class 900 RTJ flange	•	•	
RF ⁽⁴⁾	Class 1500 RTJ flange	•	•	

Table 4: Rosemount 3051SFA Annubar Flow Meter Ordering Information (continued)

RT ⁽⁴⁾	Class 2500 RTJ flange			•	•	
Opposite side support or packing gland						
0	No opposite side support or packing gland (required for Pak-Lok and Flange-Lok models)			•	•	★
Opposite side support (required for flanged models)						
C	NPT threaded opposite support assembly (extended tip)			•	•	★
D	Welded opposite support assembly (extended tip)			•	•	★
Packing gland (required for Flo-Tap models)						
	Packing gland material	Rod material	Packing material			
J ⁽⁵⁾	Stainless steel packing gland/cage nipple	Carbon steel	PTFE	•	•	
K ⁽⁵⁾	Stainless steel packing gland/cage nipple	Stainless steel	PTFE	•	•	
L ⁽⁵⁾	Stainless steel packing gland/cage nipple	Carbon steel	Graphite	•	•	
N ⁽⁵⁾	Stainless steel packing gland/cage nipple	Stainless steel	Graphite	•	•	
R	Alloy C-276 packing gland/cage nipple	Stainless steel	Graphite	•	•	
Isolation valve for Flo-Tap models						
0 ⁽³⁾	Not applicable or customer supplied			•	•	★
1	Gate valve, carbon steel			•	•	
2	Gate valve, stainless steel			•	•	
5	Ball valve, carbon steel			•	•	
6	Ball valve, stainless steel			•	•	
Temperature measurement						
T ⁽⁶⁾	Integral RTD (not available with flanged model greater than Class 600)			•	•	★
0 ⁽⁷⁾	No temperature sensor			•	•	★
R ⁽⁶⁾	Remote thermowell and RTD			•	•	
Transmitter connection platform						
3	Direct mount, integral 3-valve manifold (not available with flanged model greater than Class 600)			•	•	★
5	Direct mount, 5-valve manifold (not available with flanged model greater than Class 600)			•	•	★
7	Remote mount NPT connections (½-in. FNPT)			•	•	★
6	Direct mount, high temperature 5-valve manifold (not available with flanged model greater than Class 600)			•	•	
8	Remote mount SW connections (½-in.)			•	•	
Differential pressure range						
1	0 to 25 inH ₂ O (0 to 62,3 mbar)			•	•	★
2	0 to 250 inH ₂ O (0 to 623 mbar)			•	•	★
3	0 to 1000 inH ₂ O (0 to 2,5 bar)			•	•	★
Static pressure range						
A ⁽⁸⁾	None			•	•	★

Table 4: Rosemount 3051SFA Annubar Flow Meter Ordering Information (continued)

D	Absolute (0 to 800 psia [0 to 55,2 bar])	—	•	★
E ⁽⁹⁾	Absolute (0 to 3626 psia [0 to 250 bar])	—	•	★
J	Gage (-14.2 to 800 psig [-0,979 to 55,2 bar])	—	•	★
K ⁽⁹⁾	Gage (-14.2 to 3626 psig [-0,979 to 250 bar])	—	•	★
Transmitter output				
A	4–20 mA with digital signal based on HART protocol	•	•	★
F ⁽¹⁰⁾	FOUNDATION Fieldbus protocol (requires Plantweb housing)	•	•	★
X ⁽¹¹⁾⁽¹²⁾	Wireless (requires wireless options and Wireless Plantweb housing)	•	•	★
Transmitter housing style		Material	Conduit entry size	
00	None (customer-supplied electrical connection)	N/A	N/A	• — ★
1A	Plantweb housing	Aluminum	½–14 NPT	• • ★
1B	Plantweb housing	Aluminum	M20 x 1.5	• • ★
1J	Plantweb housing	SST	½–14 NPT	• • ★
1K	Plantweb housing	SST	M20 x 1.5	• • ★
2A	Junction box housing	Aluminum	½–14 NPT	• — ★
2B	Junction box housing	Aluminum	M20 x 1.5	• — ★
2E	Junction box housing with output for remote display and interface	Aluminum	½–14 NPT	• — ★
2F	Junction box housing with output for remote display and interface	Aluminum	M20 x 1.5	• — ★
2J	Junction box housing	SST	½–14 NPT	• — ★
2M	Junction box housing with output for remote display and interface	SST	½–14 NPT	• — ★
5A ⁽¹³⁾	Wireless Plantweb housing	Aluminum	½–14 NPT	• • ★
5J ⁽¹³⁾	Wireless Plantweb housing	SST	½–14 NPT	• • ★
7J ⁽¹¹⁾⁽¹⁴⁾	Quick Connect (A size mini, 4-pin male termination)	N/A	N/A	• — ★
1C	Plantweb housing	Aluminum	G½	• •
1L	Plantweb housing	SST	G½	• •
2C	Junction box housing	Aluminum	G½	• —
2G	Junction box housing with output for remote display and interface	Aluminum	G½	• —
Performance class⁽¹⁵⁾				
Measurement types 1, 2, 5, and 6				
3 ⁽¹⁶⁾	Ultra for Flow: 0.8% flow rate accuracy, 14:1 flow turndown, 15-year stability, 15-year limited warranty	•	•	★
5	Classic MV: 1.15% flow rate accuracy, 8:1 flow turndown, 15-yr. stability	—	•	★
Measurement types 3, 4, 7, and D				
1	Ultra: up to 0.95% flow rate accuracy, 8:1 flow turndown, 15-year stability, 15-year limited warranty	•	—	★

Table 4: Rosemount 3051SFA Annubar Flow Meter Ordering Information (continued)

2	Classic: up to 1.4% flow rate accuracy, 8:1 flow turndown, 15-year stability	•	—	★
3 ⁽¹⁶⁾	Ultra for Flow: 0.8% flow rate accuracy, 14:1 flow turndown, 15-year stability, 15-year limited warranty	•	•	★
Wireless options (requires option code X and wireless Plantweb housing)				
Update rate, operating frequency and protocol				
WA	User configurable update rate	•	•	★
Operating frequency and protocol				
3	2.4 GHz DSSS, IEC 62591 (<i>WirelessHART</i>)	•	•	★
Omni-directional wireless antenna				
WJ	Remote antenna	•	—	★
WK	External antenna	•	•	★
WM	Extended range, external antenna	•	•	★
WN	High-gain, remote antenna	•	•	
SmartPower⁽¹⁷⁾				
1	Adapter for Black Power Module (I.S. Power Module sold separately)	•	—	★
Other options (include with selected model number)				
HART revision configuration (requires HART Protocol output code A)⁽¹⁸⁾				
HR7	Configured for HART Revision 7	•	—	★
Extended product warranty				
WR3	3-year limited warranty	•	•	★
WR5	5-year limited warranty	•	•	★
Pressure testing⁽¹⁹⁾				
P1	Hydrostatic testing with certificate	•	•	
PX	Extended hydrostatic testing	•	•	
Special cleaning				
P2	Cleaning for special services	•	•	
PA	Cleaning per ASTM G93 level D (section 11.4)	•	•	
Material testing				
V1	Dye penetrant exam	•	•	
Material examination				
V2	Radiographic examination	•	•	
Flow calibration				
W1	Flow calibration (average K)	•	•	
WZ	Special calibration	•	•	
Special inspection				
QC1	Visual and dimensional inspection with certificate	•	•	★
QC7	Inspection and performance certificate	•	•	★

Table 4: Rosemount 3051SFA Annubar Flow Meter Ordering Information (continued)

Surface finish				
RL	Surface finish for low pipe Reynolds number in gas and steam	•	•	★
RH	Surface finish for high pipe Reynolds number in liquid	•	•	★
Material traceability certification⁽²⁰⁾				
Q8	Material traceability certificate per EN 10204:2004 3.1	•	•	★
Code conformance⁽²¹⁾				
J2	ANSI/ASME B31.1	•	•	
J3	ANSI/ASME B31.3	•	•	
Material conformance⁽²²⁾				
J5	NACE MR-0175/ISO 15156	•	•	
Country certification				
J6	European Pressure Directive (PED)	•	•	★
J1	Canadian Registration	•	•	
Installed in flanged pipe spool section				
H3	Class 150 flanged connection with Rosemount standard length and schedule	•	•	
H4	Class 300 flanged connection with Rosemount standard length and schedule	•	•	
H5	Class 600 flanged connection with Rosemount standard length and schedule	•	•	
Instrument connections for remote mount option				
G2	Needle valves, stainless steel	•	•	★
G6	OS and Y gate valve, stainless steel	•	•	★
G1	Needle valves, carbon steel	•	•	
G3	Needle valves, Alloy C-276	•	•	
G5	OS and Y gate valve, carbon steel	•	•	
G7	OS and Y gate valve, Alloy C-276	•	•	
Special shipment				
Y1	Mounting hardware (shipped separately)	•	•	★
Special dimensions				
VM	Variable mounting	•	•	
VT	Variable tip	•	•	
VS	Variable length spool section	•	•	
Transmitter calibration certification				
Q4	Calibration certificate for transmitter	•	•	★
QP	Calibration certificate and tamper evident seal	•	•	★
Quality certification for safety⁽¹⁾				
QS	Prior-use certificate of FMEDA data	•	—	★
QT ⁽²⁶⁾	Safety certified to IEC 61508 with certificate of FMEDA data	•	—	★
Product certifications				
E1	ATEX Flameproof	•	•	★

Table 4: Rosemount 3051SFA Annubar Flow Meter Ordering Information (continued)

I1	ATEX Intrinsic Safety	•	•	★
IA ⁽²³⁾	ATEX FISCO Intrinsic Safety	•	•	★
N1	ATEX Type n	•	•	★
ND	ATEX Dust	•	•	★
K1	ATEX Flameproof, Intrinsic Safety, Type n, Dust (combination of E1, I1, N1, and ND)	•	•	★
E4	TIIS Flameproof	•	•	★
E5	FM Explosion-proof, Dust Ignition-proof	•	•	★
I5	FM Intrinsically Safe; Nonincendive	•	•	★
IE ⁽²³⁾	FM FISCO Intrinsic Safety	•	•	★
K5	FM Explosion-proof, Dust Ignition-proof, Intrinsically Safe, Division 2 (combination of E5 and I5)	•	•	★
E6 ⁽²⁴⁾	CSA Explosion-proof, Dust Ignition-proof, Division 2	•	•	★
I6	CSA Intrinsically Safe	•	•	★
IF ⁽²³⁾	CSA FISCO Intrinsic Safety	•	•	★
K6 ⁽²⁴⁾	CSA Explosion-proof, Dust Ignition-proof, Intrinsically Safe, Division 2 (combination of E6 and I6)	•	•	★
E7	IECEx Flameproof, Dust Ignition-proof	•	•	★
I7	IECEx Intrinsic Safety	•	•	★
IG ⁽²³⁾	IECEx FISCO Intrinsic Safety	•	•	★
N7	IECEx Type n	•	•	★
K7	IECEx Flameproof, Dust Ignition-proof, Intrinsic Safety, Type n (combination of E7, I7, and N7)	•	•	★
E3	China Flameproof	•	•	★
I3	China Intrinsic Safety	•	•	★
N3	China Type n	•	—	★
EP	Republic of Korea Flameproof	•	•	★
IP	Republic of Korea Intrinsic Safety	•	•	★
KP	Republic of Korea Flameproof, Intrinsic Safety	•	•	★
KA ⁽²⁴⁾	ATEX and CSA Flameproof, Intrinsically Safe, Division 2 (combination of E1, I1, E6, and I6)	•	•	★
KB ⁽²⁴⁾	FM and CSA Explosion-proof, Dust Ignition-proof, Intrinsically Safe, Division 2 (combination of E5, E6, I5, and I6)	•	•	★
EM	Technical Regulations Customs Union (EAC) Flameproof	•	•	★
IM	Technical Regulations Customs Union (EAC) Intrinsic Safety	•	•	★
KM	Technical Regulations Customs Union (EAC) Flameproof, Intrinsic Safety	•	•	★
KG ⁽²³⁾	ATEX, FM, CSA, and IECEx FISCO Intrinsic Safety (combination of IA, IE, IF, and IG)	•	—	★
E2	INMETRO Flameproof	•	•	★
I2	INMETRO Intrinsic Safety	•	•	★
K2	INMETRO Flameproof, Intrinsic Safety	•	•	★

Table 4: Rosemount 3051SFA Annubar Flow Meter Ordering Information (continued)

IB	INMETRO FISCO Intrinsic Safety	•	—	★
KC	FM and ATEX Explosion-proof, Intrinsically Safe, Division 2 (combination of E5, E1, I5, and I1)	•	•	★
KD ⁽²⁴⁾	FM, CSA, and ATEX Explosion-proof, Intrinsically Safe (combination of E5, I5, E6, I6, E1, and I1)	•	•	★
Shipboard approvals⁽²⁵⁾				
SBS	American Bureau of Shipping	•	•	★
SBV	Bureau Veritas (BV) Type Approval	•	•	★
SDN	Det Norske Veritas (DNV) Type Approval	•	•	★
SLL	Lloyds Register (LR) Type Approval	•	•	★
Sensor fill fluid and O-ring options				
L1	Inert sensor fill fluid	•	•	★
L2	Graphite-filled (PTFE) O-ring	•	•	★
LA	Inert sensor fill fluid and graphite-filled (PTFE) O-ring	•	•	★
Digital display⁽²⁶⁾				
M5	Plantweb LCD display (requires Plantweb housing)	•	•	★
M7 ⁽²⁷⁾⁽²⁸⁾⁽²⁹⁾	Remote mount LCD display and interface, Plantweb housing, no cable; SST bracket	•	—	★
M8 ⁽²⁷⁾⁽²⁸⁾	Remote mount LCD display and interface, Plantweb housing, 50 feet (15 m) cable; SST bracket	•	—	★
M9 ⁽²⁷⁾⁽²⁸⁾	Remote mount LCD display and interface, Plantweb housing, 100 feet (31 m) cable; SST bracket	•	—	★
Transient protection⁽³⁰⁾				
T1	Transient terminal block	•	•	★
Manifold for remote mount option				
F2	3-valve manifold, stainless steel	•	•	★
F6	5-valve manifold, stainless steel	•	•	★
F1	3-valve manifold, carbon steel	•	•	
F3	3-valve manifold, Alloy C-276	•	•	
F5	5-valve manifold, carbon steel	•	•	
F7	5-valve manifold, Alloy C-276	•	•	
Plantweb control functionality				
A01	FOUNDATION Fieldbus advanced control function block suite	•	•	★
Diagnostics suite				
D01	FOUNDATION Fieldbus diagnostics suite (Process Intelligence, Plugged Impulse Line diagnostic)	•	—	★
DA2 ⁽³¹⁾	Advanced HART diagnostic suite (Process Intelligence, Loop Integrity, Plugged Impulse Line diagnostic, Process Alerts, Service Alerts, Variable Log, Event Log)	•	—	★
Cold temperature⁽³²⁾⁽³³⁾				
BRR	−58 °F (−50 °C) cold temperature start-up	—	•	★

Table 4: Rosemount 3051SFA Annubar Flow Meter Ordering Information (continued)

Alarm limit ⁽³³⁾				
C4	NAMUR alarm and saturation levels, high alarm	•	•	★
C5	NAMUR alarm and saturation levels, low alarm	•	•	★
C6	Custom alarm and saturation levels, high alarm	•	•	★
C7	Custom alarm and saturation levels, low alarm	•	•	★
C8	Low alarm (standard Rosemount alarm and saturation levels)	•	•	★
Hardware adjustments and ground screw				
D1 ⁽²⁷⁾⁽³³⁾⁽³⁴⁾	Hardware adjustments (zero, span, alarm, security)	•	—	★
D4 ⁽³⁵⁾	External ground screw assembly	•	•	★
DA ⁽³³⁾⁽²⁷⁾⁽³⁴⁾	Hardware adjustments (zero, span, alarm, security) and external ground screw assembly	•	—	★
Conduit plug				
DO	316 SST conduit plug	•	•	★
Conduit electrical connector ⁽³⁶⁾				
GE	M12, 4-pin, male connector (eurofast [®])	•	•	★
GM	A size mini, 4-pin, male connector (minifast [®])	•	•	★
Typical model number: 3051SFA D L 060 D C H P S 2 T1 0 0 0 3 2A A 1A 3				

- (1) For option code A: 4–20mA HART only.
- (2) See the Rosemount DP flow meters and Primary Elements Product Data Sheet for Pipe I.D. table.
- (3) Provide the “A” dimension for Flanged, Flange-Lok, and Threaded Flo-Tap models. Provide the “B” dimension for Flange Flo-Tap models.
- (4) Available in remote mount applications only.
- (5) The cage nipple is constructed of 304SST.
- (6) Temperature Measurement Option code T or R is required for Measurement Type codes 1, 3, 5, and 7.
- (7) Required for Measurement Type codes 2, 4, 6, and D.
- (8) Required for Measurement Type codes 3, 4, 7, and D.
- (9) For Measurement Type codes 1, 2, 5, and 6 with DP range 1, absolute limits are 0.5 to 2000 psi (0,03 to 137,9 bar) and gage limits are -14.2 to 2000 psig (-0,98 to 137,9 bar).
- (10) Transmitter output code F is only available with Measurement type code 1, 2, 5, 6, and D.
- (11) Only intrinsically safe approval codes apply.
- (12) Only available with Measurement Types D and 6.
- (13) Only available with output code X.
- (14) Only available with output code A.
- (15) For details, see [Specifications](#).
- (16) Only available with differential pressure ranges 2 and 3, and silicone fill fluid.
- (17) Long-life Power Module must be shipped separately, order Power Module 701PBKKF.
- (18) Option HR7 configures the HART output to HART Revision 7. This option requires the selection of the Advanced Diagnostics (DA2) option. The device with this option can be field configured to HART Revision 5 or 7 if desired.
- (19) Applies to assembled flow meter only, mounting not tested.
- (20) Instrument connections for remote mount options and isolation valves for Flo-tap models are not included in the material traceability certification.
- (21) Not available with transmitter connection platform 6.
- (22) Materials of construction comply with metallurgical requirements within NACE MR0175/ISO 15156 for sour oil field production environments. Environmental limits apply to certain materials. Consult latest standard for details. Selected materials also conform to NACE MR0103 for sour refining environments.
- (23) FISCO is only available with Transmitter output code F.
- (24) Not available with M20 or G½ conduit entry size.
- (25) Not available with transmitter output code F with Measurement Types 1, 2, 5, or 6.

- (26) Not available with housing code 7J.
 (27) Not available with output code X. Only available with Measurement Type D.
 (28) Not available with output code F, option code DA2, or option code QT.
 (29) See the Rosemount 3051S [Reference Manual](#) for cable requirements. Contact an Emerson representative for additional information.
 (30) Not available with Housing code 5A, 5J, or 7J. External ground screw assembly (option code D4) is included with the T1 option. The T1 option is not needed with FISCO Product Certifications.
 (31) Includes Hardware Adjustments (option code D1) as standard. Not available with output code X or F. Only available with Measurement Type D.
 (32) -58 °F (50 °C) for Measurement Type 1-7.
 (33) Not available with output code F.
 (34) Not available with housing codes 2E, 2F, 2G, 2M, 5A, 5J, or 7J.
 (35) This assembly is included with options EP, KP, E1, N1, K1, ND, E4, E7, N7, K7, E2, E3, KA, KC, KD, IA, IE, N3, T1, EM, and KM.
 (36) Not available with Housing code 5A, 5J, or 7J. Available with intrinsically Safe approvals only. For FM intrinsically Safe; Nonincendive (option code I5) or FM FISCO Intrinsically Safe (option code IE), install in accordance with Rosemount drawing 03151-1009.

Rosemount 3051SFC Compact Flow Meter



- Compact conditioning flow meters reduce straight piping requirements to 2D upstream and 2D downstream from most flow disturbances
- Simple installation of compact flow meters between any existing raised-face flanges

Specification and selection of product materials, options, or components must be made by the purchaser of the equipment. See [Material selection](#) for more information.

For additional technical data and ordering information for Rosemount Annubar Primary Elements, refer to the Rosemount DP Flow meters and Primary Elements [Product Data Sheet](#).

The starred offerings (★) represent the most common options and should be selected for best delivery. The non-starred offerings are subject to additional delivery lead time.

Table 5: Rosemount 3051SFC Compact Flow Meter Ordering Information

Model	Product description	Measurement type		
		D	1-7	
3051SFC	Compact orifice flow meter	•	•	
Measurement type				
1 ⁽¹⁾	Fully compensated mass and energy flow calculations – differential and static pressures w/ temperature	—	•	★
2	Compensated flow calculations – differential and static pressures	—	•	★
3	Compensated flow calculations – differential pressure and temperature	—	•	★
4	Compensated flow calculations – differential pressure	—	•	★
D	Differential pressure	•	—	★
5	Process variables only (no flow calculations) – differential and static pressures w/ temperature	—	•	★
6	Process variables only (no flow calculations) – differential and static pressures	—	•	★
7	Process variables only (no flow calculations) – differential pressure and temperature	—	•	★

- = Available
 — = Unavailable

Table 5: Rosemount 3051SFC Compact Flow Meter Ordering Information (continued)

Primary element technology				
A	Annubar averaging pitot tube	•	•	★
C	Conditioning orifice plate	•	•	★
P	Orifice plate	•	•	★
Material type				
S	316 SST	•	•	★
Line size				
005 ⁽²⁾	½-in. (15 mm)	•	•	★
010 ⁽²⁾	1-in. (25 mm)	•	•	★
015 ⁽²⁾	1½-in. (40 mm)	•	•	★
020	2-in. (50 mm)	•	•	★
030	3-in. (80 mm)	•	•	★
040	4-in. (100 mm)	•	•	★
060	6-in. (150 mm)	•	•	★
080	8-in. (200 mm)	•	•	★
100 ⁽³⁾⁽⁴⁾	10-in. (250 mm)	•	•	★
120 ⁽³⁾⁽⁴⁾	12-in. (300 mm)	•	•	★
Primary element type				
N000	Annubar sensor size 1	•	•	★
N040	0.40 Beta ratio (β)	•	•	★
N050	0.50 Beta ratio (β)	•	•	★
N065 ⁽⁵⁾	0.65 Beta ratio (β)	•	•	★
Temperature measurement				
T ⁽⁶⁾	Integral RTD	—	•	★
0 ⁽⁷⁾	No temperature sensor	•	•	★
R ⁽⁶⁾	Remote thermowell and RTD	•	•	
Transmitter connection platform				
3	Direct mount	•	•	★
7	Remote mount, NPT connections	•	•	★
Differential pressure range				
1	0 to 25 inH ₂ O (0 to 62,3 mbar)	•	•	★
2	0 to 250 inH ₂ O (0 to 623 mbar)	•	•	★
3	0 to 1000 inH ₂ O (0 to 2,5 bar)	•	•	★
Static pressure range				
A ⁽⁸⁾	None	•	•	★
D	Absolute (0 to 800 psia [0 to 55,15 bar])	—	•	★
E ⁽⁹⁾	Absolute (0 to 3626 psia [0 to 250,00 bar])	—	•	★
J	Gage (–14.2 to 800 psig [–0,98 to 55,15 bar])	—	•	★

Table 5: Rosemount 3051SFC Compact Flow Meter Ordering Information (continued)

K ⁽⁹⁾	Gage (-14.2 to 3626 psig [-0,98 to 250,00 bar])			—	•	★
Transmitter output						
A	4–20 mA with digital signal based on HART protocol			•	•	★
F ⁽¹⁰⁾⁽¹¹⁾	FOUNDATION Fieldbus protocol			•	•	★
X ⁽¹²⁾⁽¹³⁾	Wireless			•	—	★
Transmitter housing style		Material	Conduit entry size			
00	None (customer-supplied electrical connection)	N/A	N/A	•	—	★
1A	Plantweb housing	Aluminum	½–14 NPT	•	•	★
1B	Plantweb housing	Aluminum	M20 x 1.5	•	•	★
1J	Plantweb housing	SST	½–14 NPT	•	•	★
1K	Plantweb housing	SST	M20 x 1.5	•	•	★
2A	Junction box housing	Aluminum	½–14 NPT	•	—	★
2B	Junction box housing	Aluminum	M20 x 1.5	•	—	★
2E	Junction box housing with output for remote display and interface	Aluminum	½–14 NPT	•	—	★
2F	Junction box housing with output for remote display and interface	Aluminum	M20 x 1.5	•	—	★
2J	Junction box housing	SST	½–14 NPT	•	—	★
2M	Junction box housing with output for remote display and interface	SST	½–14 NPT	•	—	★
5A ⁽¹⁴⁾	Wireless Plantweb housing	Aluminum	½–14 NPT	•	•	★
5J ⁽¹⁴⁾	Wireless Plantweb housing	SST	½–14 NPT	•	•	★
7J ⁽¹²⁾⁽¹⁵⁾	Quick connect (A size mini, 4-pin male termination)	N/A	N/A	•	—	★
1C	Plantweb housing	Aluminum	G½	•	•	
1L	Plantweb housing	SST	G½	•	•	
2C	Junction box housing	Aluminum	G½	•	—	
2G	Junction box housing with output for remote display and interface	Aluminum	G½	•	—	
Performance class⁽¹⁶⁾						
Measurement types 1, 2, 5, and 6						
3 ⁽¹⁷⁾	Ultra for flow: 0.75% flow rate accuracy, 14:1 flow turndown, 15-yr stability, 15-yr limited warranty			•	•	★
5	Classic MV: 1.10% flow rate accuracy, 8:1 flow turndown, 15-yr stability			—	•	★
Measurement types 3, 4, 7, and D						
1	Ultra: 0.90% flow rate accuracy, 8:1 flow turndown, 15-yr stability, 15-yr limited warranty			•	—	★
2	Classic: 1.40% flow rate accuracy, 8:1 flow turndown, 15-yr stability			•	—	★
3 ⁽¹⁷⁾	Ultra for flow: 0.75% flow rate accuracy, 14:1 flow turndown, 15-yr stability, 15-yr limited warranty			•	•	★

Table 5: Rosemount 3051SFC Compact Flow Meter Ordering Information (continued)

Wireless options (requires option code X and wireless Plantweb housing)				
Update rate, operating frequency, and protocol				
WA	User configurable update rate	•	•	★
Operating frequency and protocol				
3	2.4 GHz DSSS, IEC 62591 (<i>WirelessHART</i>)	•	•	★
Omni-directional wireless antenna				
WJ	Remote antenna	•	—	★
WK	External antenna	•	•	★
WM	Extended range, external antenna	•	•	★
WN	High-gain, remote antenna	•	•	
SmartPower⁽¹⁸⁾				
1	Adapter for Black Power Module (I.S. Power Module sold separately)	•	•	★
Other options (include with selected model number)				
HART Revision configuration (requires HART Protocol output code A)⁽¹⁹⁾				
HR7	Configured for HART Revision 7	•	—	★
Extended product warranty				
WR3	3-year limited warranty	•	•	★
WR5	5-year limited warranty	•	•	★
Installation accessories				
A ⁽²⁰⁾	ANSI alignment ring (Class 150)	•	•	★
C ⁽²⁰⁾	ANSI alignment ring (Class 300)	•	•	★
D ⁽²⁰⁾	ANSI alignment ring (Class 600)	•	•	★
G	DIN alignment ring (PN 16)	•	•	★
H	DIN alignment ring (PN 40)	•	•	★
J	DIN alignment ring (PN 100)	•	•	★
B	JIS alignment ring (10K)	•	•	
R	JIS alignment ring (20K)	•	•	
S	JIS alignment ring (40K)	•	•	
Remote adapters				
E	Flange adapters 316 SST (½-in. NPT)	•	•	★
High temperature applications				
T	Graphite valve packing ($T_{max} = 850$ °F)	•	•	
Flow calibration				
WC ⁽²¹⁾	Flow calibration, 3 Pt, conditioning option C (all pipe schedules)	•	•	
WD ⁽²²⁾⁽²³⁾	Flow calibration, 10 Pt, conditioning option C (all schedules)	•	•	
	Annubar option A (schedule 40)			

Table 5: Rosemount 3051SFC Compact Flow Meter Ordering Information (continued)

Pressure testing				
P1	Hydrostatic testing with certificate	•	•	
Special cleaning⁽²⁴⁾				
P2	Cleaning for special processes	•	•	
PA	Cleaning per ASTM G93 level D (section 11.4)	•	•	
Special inspection				
QC1	Visual and dimensional inspection with certificate	•	•	★
QC7	Inspection and performance certificate	•	•	★
Transmitter calibration certification				
Q4	Calibration data certificate for transmitter	•	•	★
QP	Calibration certificate and tamper evident seal	•	•	★
Quality certification for safety⁽²⁵⁾				
QS	Prior-use certificate of FMEDA data	•	•	★
QT ⁽²⁶⁾	Safety Certified to IEC 61508 with certificate of FMEDA data	•	•	★
Material traceability certifications				
Q8	Material traceability certification per EN 10204:2004 3.1	•	•	★
Code conformance				
J2	ANSI/ASME B31.1	•	•	
J3	ANSI/ASME B31.3	•	•	
J4	ANSI/ASME B31.8	•	•	
Material conformance⁽²⁷⁾				
J5	NACE MR-0175/ISO 15156	•	•	
Country certification				
J1	Canadian registration	•	•	
Product certifications				
E1	ATEX Flameproof	•	•	★
I1	ATEX Intrinsic Safety	•	•	★
IA ⁽²⁸⁾	ATEX FISCO Intrinsic Safety	•	•	★
N1	ATEX Type n	•	•	★
ND	ATEX Dust	•	•	★
K1	ATEX Flameproof, Intrinsic Safety, Type n, Dust (combination of E1, I1, N1, and ND)	•	•	★
E4	TIIS Flameproof	•	•	★
E5	FM Explosion-proof, Dust Ignition-proof	•	•	★
I5	FM Intrinsically Safe; Nonincendive	•	•	★
IE ⁽²⁸⁾	FM FISCO Intrinsic Safety	•	•	★
K5	FM Explosion-proof, Dust Ignition-proof, Intrinsically Safe, Division 2 (combination of E5 and I5)	•	•	★
E6 ⁽²⁹⁾	CSA Explosion-proof, Dust Ignition-proof, Division 2	•	•	★

Table 5: Rosemount 3051SFC Compact Flow Meter Ordering Information (continued)

IF ⁽²⁸⁾	CSA FISCO Intrinsic Safety	•	•	★
I6	CSA Intrinsically Safe	•	•	★
K6 ⁽²⁹⁾	CSA Explosion-proof, Dust Ignition-proof, Intrinsically Safe, Division 2 (combination of E6 and I6)	•	•	★
E7	IECEX Flameproof, Dust Ignition-proof	•	•	★
IG ⁽²⁸⁾	IECEX FISCO Intrinsic Safety	•	•	★
I7	IECEX Intrinsic Safety	•	•	★
N7	IECEX Type n	•	•	★
K7	IECEX Flameproof, Dust Ignition-proof, Intrinsic Safety, Type n (combination of E7, I7, and N7)	•	•	★
E3	China Flameproof	•	•	★
I3	China Intrinsic Safety	•	•	★
N3	China Type n	•	—	★
EP	Republic of Korea Flameproof	•	•	★
IP	Republic of Korea Intrinsic Safety	•	•	★
KP	Republic of Korea Flameproof, Intrinsic Safety	•	•	★
EM	Technical Regulations Customs Union (EAC) Flameproof	•	•	★
IM	Technical Regulations Customs Union (EAC) Intrinsic Safety	•	•	★
KM	Technical Regulations Customs Union (EAC) Flameproof, Intrinsic Safety	•	•	★
KG ⁽²⁸⁾	ATEX, FM, CSA, and IECEX FISCO Intrinsic Safety (combination of IA, IE, IF, and IG)	•	—	★
E2	INMETRO Flameproof	•	•	★
I2	INMETRO Intrinsic Safety	•	•	★
K2	INMETRO Flameproof, Intrinsic Safety	•	•	★
IB	INMETRO FISCO Intrinsic Safety	•	—	
KA ⁽²⁹⁾	ATEX and CSA Flameproof, Intrinsically Safe, Division 2 (combination of E1, I1, E6, and I6)	•	•	★
KB ⁽²⁹⁾	FM and CSA Explosion-proof, Dust Ignition-proof, Intrinsically Safe, Division 2 (combination of E5, E6, I5, and I6)	•	•	★
KC	FM and ATEX Explosion-proof, Intrinsically Safe, Division 2 (combination of E5, E1, I5, and I1)	•	•	★
KD ⁽²⁹⁾	FM, CSA, and ATEX Explosion-proof, Intrinsically Safe (combination of E5, E6, E1, I5, I6, and I1)	•	•	★
Shipboard approvals⁽³⁰⁾				
SBS	American Bureau of Shipping	•	•	★
SBV	Bureau Veritas (BV) Type Approval	•	•	★
SDN	Det Norske Veritas (DNV) Type Approval	•	•	★
SLL	Lloyds Register (LR) Type Approval	•	•	★
Sensor fill fluid and O-ring options				
L1	Inert sensor fill fluid	•	•	★
L2	Graphite-filled (PTFE) O-ring	•	•	★
LA	Inert sensor fill fluid and graphite-filled (PTFE) O-ring	•	•	★

Table 5: Rosemount 3051SFC Compact Flow Meter Ordering Information (continued)

Digital display⁽²⁶⁾				
M5	Plantweb LCD display	•	•	★
M7 ⁽³¹⁾⁽³²⁾⁽³³⁾	Remote mount LCD display and interface, Plantweb housing, no cable, SST bracket	•	—	★
M8 ⁽³¹⁾⁽³²⁾	Remote mount LCD display and interface, Plantweb housing, 50 feet (15m) cable, SST bracket	•	—	★
M9 ⁽³¹⁾⁽³²⁾	Remote mount LCD display and interface, Plantweb housing, 100 feet (31m) cable, SST bracket	•	—	★
Transient protection⁽³⁴⁾				
T1	Transient terminal block	•	•	★
Manifold for remote mount option				
F2	3-valve manifold, SST	•	•	★
F6	5-valve manifold, SST	•	•	★
Plantweb control functionality				
A01	FOUNDATION Fieldbus advanced control function block suite	•	•	★
Diagnostics suite				
D01	FOUNDATION Fieldbus diagnostics suite (Process Intelligence, Plugged Impulse Line diagnostic)	•	—	★
DA2 ⁽³⁵⁾	Advanced HART diagnostic suite (Process Intelligence, Loop Integrity, Plugged Impulse Line diagnostic, Process Alerts, Service Alerts, Variable Log, Event Log)	•	—	★
Cold temperature^{(36) (37)(38)}				
BRR	−58 °F (−50 °C) cold temperature start-up	•	•	★
Alarm limit⁽³⁶⁾				
C4	NAMUR alarm and saturation levels, high alarm	•	•	★
C5	NAMUR alarm and saturation levels, low alarm	•	•	★
C6	Custom alarm and saturation levels, high alarm	•	•	★
C7	Custom alarm and saturation levels, low alarm	•	•	★
C8	Low alarm (standard Rosemount alarm and saturation levels)	•	•	★
Hardware adjustments and ground screw				
D1 ⁽³¹⁾⁽³⁶⁾⁽³⁸⁾	Hardware adjustments (zero, span, alarm, security)	•	—	★
D4 ⁽³⁹⁾	External ground screw assembly	•	•	★
DA ⁽³¹⁾⁽³⁶⁾⁽³⁸⁾⁽³⁹⁾	Hardware adjustments (zero, span, alarm, security) and external ground screw assembly	•	—	★
Conduit plug				
DO	316 SST conduit plug	•	•	★
Conduit electrical connector⁽⁴⁰⁾				
ZE	M12, 4-pin, male connector (eurofast [®])	•	•	★
ZM	A size mini, 4-pin, male connector (minifast [®])	•	•	★
Typical model number: 3051SFC 1 C S 060 N 065 T 3 2 J A 1A 3				

(1) For option code A: 4–20 mA HART only.

(2) Available with primary element technology P only.

(3) For the 10-in. (250 mm) and 12-in. (300 mm) line sizes, the alignment ring must be ordered (Installation Accessories).

- (4) 10-in. (250 mm) and 12-in. (300 mm) line sizes not available with primary element technology code A.
- (5) For 2-in. (50 mm) line size the beta ratio is 0.6 for primary element technology code C.
- (6) Only available with Measurement Type codes 1, 3, 5, 7.
- (7) Required for Measurement Type codes 2, 4, 6, and D.
- (8) Required for Measurement Type codes 3, 4, 7, and D.
- (9) For Measurement Type codes 1, 2, 5, and 6 with DP range 1, absolute limits are 0.5 to 2000 psi (0,03 to 137,9 bar) and gage limits are -14.2 to 2000 psig (-0,98 to 137,9 bar).
- (10) Requires Plantweb housing.
- (11) Transmitter output code F is only available with Measurement type code 1, 2, 5, 6, and D.
- (12) Only intrinsically safe approval codes apply.
- (13) Only available with Measurement Types D and 6.
- (14) Only available with output code X.
- (15) Available with output code A only.
- (16) For details, see [Specifications](#).
- (17) Only available with differential pressure ranges 2 and 3, and silicone fill fluid.
- (18) Long-life Power Module must be shipped separately, order Power Module 701PBKKF.
- (19) Option HR7 configures the HART output to HART Revision 7. This option requires the selection of the Advanced Diagnostics (DA2) option. The device with this option can be field configured to HART Revision 5 or 7 if desired.
- (20) Only required for 10-in. (250 mm) and 12-in. (300mm) line sizes.
- (21) Available with primary element technology code C only.
- (22) Available with primary element technology codes C or A only.
- (23) For Annubar Option A, consult factory for pipe schedules other than Sch. 40.
- (24) Available with primary element technology C or P only.
- (25) Not available with output codes F or X.
- (26) Not available with housing code 7J.
- (27) Materials of Construction comply with metallurgical requirements within NACE MR0175/ISO for sour oil field production environments. Environmental limits apply to certain materials. Consult latest standard for details. Selected materials also conform to NACE MR0103 for sour refining environments.
- (28) FISCO is only available with Transmitter output code F.
- (29) Not available with M20 or G½ conduit entry size.
- (30) Not available with transmitter output code F with Measurement Types 1, 2, 5, or 6.
- (31) Not available with output code X. Only available with Measurement Type D.
- (32) Not available with output code F, option code DA2, or option code QT.
- (33) See the Rosemount 3051S [Reference Manual](#) for cable requirements. Contact an Emerson representative for additional information.
- (34) Not available with Housing code 00, 5A, 5J, or 7J. External ground screw assembly (option code D4) is included with the T1 option. The T1 option is not needed with FISCO Product Certifications.
- (35) Includes Hardware Adjustments (option code D1) as standard. Not available with output code X or F. Only available with Measurement Type D.
- (36) Not available with Output Protocol code F.
- (37) -58 °F (50 °C) for Measurement Type 1-7.
- (38) Not available with housing codes 2E, 2F, 2G, 2M, 5A, 5J, or 7J.
- (39) This assembly is included with options EP, KP, E1, N1, K1, ND, E4, E7, K7, E3, KA, KC, KD, IA, T1, EM, and KM.
- (40) Not available with Housing code 5A, 5J, or 7J. Available with Intrinsically Safe approvals only. For FM Intrinsically Safe; Nonincendive (option code I5) or FM FISCO Intrinsically Safe (option code IE), install in accordance with Rosemount drawing 03151-1009.

Rosemount 3051SFP Integral Orifice Flow Meter



- Precision honed pipe section for increased accuracy in small line sizes
- Self-centering plate design prevents alignment errors that magnify measurement inaccuracies in small line sizes

Specification and selection of product materials, options, or components must be made by the purchaser of the equipment. See [Material selection](#) for more information.

For additional technical data and ordering information for Rosemount Annubar Primary Elements, refer to the Rosemount DP Flow meters and Primary Elements [Product Data Sheet](#).

The starred offerings (★) represent the most common options and should be selected for best delivery. The non-starred offerings are subject to additional delivery lead time.

Table 6: Rosemount 3051SFP Integral Orifice Flow Meter Ordering Information

<ul style="list-style-type: none"> • = Available — = Unavailable 				
Model	Product description	Measurement type		
		D	1-7	
3051SFP	Integral orifice flow meter	•	•	
Measurement type				
1	Fully compensated mass and energy ⁽¹⁾ flow calculations – differential and static pressures with temperature	—	•	★
2	Compensated flow calculations – differential and static pressures	—	•	★
3	Compensated flow calculations – differential pressure and temperature	—	•	★
4	Compensated flow calculations – differential pressure	—	•	★
D	Differential pressure	•	—	★
5	Process variables only (no flow calculations) – differential and static pressures with temperature	—	•	★
6	Process variables only (no flow calculations) – differential and static pressures	—	•	★
7	Process variables only (no flow calculations) – differential pressure and temperature	—	•	★
Body material				
S	316 SST, 2-bolt	•	•	★
F	316 SST, 4-bolt	•	•	★
Line size				
005	½-in. (15 mm)	•	•	★
010	1-in. (25 mm)	•	•	★
015	1½-in. (40 mm)	•	•	★
Process connection				
T1	NPT female body (not available with thermowell and RTD)	•	•	★
S1 ⁽²⁾	Socket weld body (not available with thermowell and RTD)	•	•	★
P1	Pipe ends: NPT threaded	•	•	★
P2	Pipe ends: beveled	•	•	★
D1	Pipe ends: flanged, RF, DIN PN16, slip-on	•	•	★
D2	Pipe ends: flanged, RF, DIN PN40, slip-on	•	•	★
D3	Pipe ends: flanged, RF, DIN PN100, slip-on	•	•	★
W1	Pipe ends: flanged, RF, ANSI Class 150, weld-neck	•	•	★
W3	Pipe ends: flanged, RF, ANSI Class 300, weld-neck	•	•	★
W6	Pipe ends: flanged, RF, ANSI Class 600, weld-neck	•	•	★
W9	Pipe ends: flanged, RF, ANSI Class 900, weld-neck	•	•	★
A1	Pipe ends: flanged, RF, ANSI Class 150, slip-on	•	•	

Table 6: Rosemount 3051SFP Integral Orifice Flow Meter Ordering Information (continued)

A3	Pipe ends: flanged, RF, ANSI Class 300, slip-on	•	•	
A6	Pipe ends: flanged, RF, ANSI Class 600, slip-on	•	•	
R1	Pipe ends: flanged, RTJ, ANSI Class 150, slip-on	•	•	
R3	Pipe ends: flanged, RTJ, ANSI Class 300, slip-on	•	•	
R6	Pipe ends: flanged, RTJ, ANSI Class 600, slip-on	•	•	
R9	Pipe ends: flanged, RTJ, ANSI Class 900, weld-neck	•	•	
P9	Special process connection	•	•	
Orifice plate material				
S	316 SST	•	•	★
H	Alloy C-276	•	•	
M	Alloy 400	•	•	
Bore size option				
0066	0.066-in. (1,68 mm) for ½-in. pipe	•	•	★
0109	0.109-in. (2,77 mm) for ½-in. pipe	•	•	★
0160	0.160-in. (4,06 mm) for ½-in. pipe	•	•	★
0196	0.196-in. (4,98 mm) for ½-in. pipe	•	•	★
0260	0.260-in. (6,60 mm) for ½-in. pipe	•	•	★
0340	0.340-in. (8,64 mm) for ½-in. pipe	•	•	★
0150	0.150-in. (3,81 mm) for 1-in. pipe	•	•	★
0250	0.250-in. (6,35 mm) for 1-in. pipe	•	•	★
0345	0.345-in. (8,76 mm) for 1-in. pipe	•	•	★
0500	0.500-in. (12,70 mm) for 1-in. pipe	•	•	★
0630	0.630-in. (16,00 mm) for 1-in. pipe	•	•	★
0800	0.800-in. (20,32 mm) for 1-in. pipe	•	•	★
0295	0.295-in. (7,49 mm) for 1½-in. pipe	•	•	★
0376	0.376-in. (9,55 mm) for 1½-in. pipe	•	•	★
0512	0.512-in. (13,00 mm) for 1½-in. pipe	•	•	★
0748	0.748-in. (19,00 mm) for 1½-in. pipe	•	•	★
1022	1.022-in. (25,96 mm) for 1½-in. pipe	•	•	★
1184	1.184-in. (30,07 mm) for 1½-in. pipe	•	•	★
0010	0.010-in. (0,25 mm) for ½-in. pipe	•	•	
0014	0.014-in. (0,36 mm) for ½-in. pipe	•	•	
0020	0.020-in. (0,51 mm) for ½-in. pipe	•	•	
0034	0.034-in. (0,86 mm) for ½-in. pipe	•	•	
Transmitter connection platform				
D3	Direct mount, 3-valve manifold, SST	•	•	★
D5	Direct mount, 5-valve manifold, SST	•	•	★
R3	Remote mount, 3-valve manifold, SST	•	•	★

Table 6: Rosemount 3051SFP Integral Orifice Flow Meter Ordering Information (continued)

R5	Remote mount, 5-valve manifold, SST	•	•	★
D4	Direct mount, 3-valve manifold, Alloy C-276	•	•	
D6	Direct mount, 5-valve manifold, Alloy C-276	•	•	
D7	Direct mount, high temperature, 5-valve manifold, SST	•	•	
R4	Remote mount, 3-valve manifold, Alloy C-276	•	•	
R6	Remote mount, 5-valve manifold, Alloy C-276	•	•	
Differential pressure range				
1	0 to 25 inH ₂ O (0 to 62,3 mbar)	•	•	★
2	0 to 250 inH ₂ O (0 to 623 mbar)	•	•	★
3	0 to 1000 inH ₂ O (0 to 2,5 bar)	•	•	★
Static pressure range				
A ⁽³⁾	None	•	•	★
D	Absolute (0 to 800 psia [0 to 55,2 bar])	—	•	★
E ⁽⁴⁾	Absolute (0 to 3626 psia [0 to 250 bar])	—	•	★
J	Gage (–14.2 to 800 psig [–0,979 to 55,2 bar])	—	•	★
K ⁽⁴⁾	Gage (–14.2 to 3626 psig [–0,979 to 250 bar])	—	•	★
Transmitter output				
A	4–20 mA with digital signal based on HART protocol	•	•	★
F ⁽⁵⁾	FOUNDATION Fieldbus (requires Plantweb housing)	•	•	★
X ⁽⁶⁾⁽⁷⁾	Wireless (requires wireless options and wireless Plantweb housing)	•	•	★
Transmitter housing style				
		Material	Conduit entry size	
00	None (customer-supplied electrical connection)	N/A	N/A	• — ★
1A	Plantweb housing	Aluminum	½–14 NPT	• • ★
1B	Plantweb housing	Aluminum	M20 x 1.5	• • ★
1J	Plantweb housing	SST	½–14 NPT	• • ★
1K	Plantweb housing	SST	M20 x 1.5	• • ★
2A	Junction box housing	Aluminum	½–14 NPT	• — ★
2B	Junction box housing	Aluminum	M20 x 1.5	• — ★
2E	Junction box housing with output for remote display and interface	Aluminum	½–14 NPT	• — ★
2F	Junction box housing with output for remote display and interface	Aluminum	M20 x 1.5	• — ★
2J	Junction box housing	SST	½–14 NPT	• — ★
2M	Junction box housing with output for remote display and interface	SST	½–14 NPT	• — ★
5A ⁽⁸⁾	Wireless Plantweb housing	Aluminum	½–14 NPT	• • ★
5J ⁽⁸⁾	Wireless Plantweb housing	SST	½–14 NPT	• • ★
7J ⁽⁶⁾⁽⁹⁾	Quick connect (A size mini, 4-pin male termination)	N/A	N/A	• — ★
1C	Plantweb housing	Aluminum	G½	• •

Table 6: Rosemount 3051SFP Integral Orifice Flow Meter Ordering Information (continued)

1L	Plantweb housing	SST	G½	•	•	
2C	Junction Box housing	Aluminum	G½	•	—	
2G	Junction Box housing with output for remote display and interface	Aluminum	G½	•	—	
Performance class⁽¹⁰⁾						
Measurement types 1, 2, 5, and 6						
3 ⁽¹¹⁾	Ultra for Flow: 0.95% flow rate accuracy, 14:1 flow turndown, 15-year stability, 15-year limited warranty			•	•	★
5	Classic MV: 1.25% flow rate accuracy, 8:1 flow turndown, 15-year stability			—	•	★
Measurement types 3, 4, 7, and D						
1	Ultra: 1.05% flow rate accuracy, 8:1 flow turndown, 15-year stability, 15-year limited warranty			•	•	★
2	Classic: 1.50% flow rate accuracy, 8:1 flow turndown, 15-year stability			•	•	★
3 ⁽¹¹⁾	Ultra for Flow: 0.95% flow rate accuracy, 14:1 flow turndown, 15-year stability, 15-year limited warranty			•	•	★
Wireless options (requires option code X and wireless Plantweb housing)						
Update rate, operating frequency and protocol						
WA	User configurable update rate			•	•	★
Operating frequency and protocol						
3	2.4 GHz DSSS, IEC 62591 (<i>WirelessHART</i>)			•	•	★
Omni-directional wireless antenna						
WJ	Remote antenna			•	—	★
WK	External antenna			•	•	★
WM	Extended range, external antenna			•	•	★
WN	High-gain, remote antenna			•	•	
SmartPower⁽¹²⁾						
1	Adapter for Black Power Module (I.S. Power Module sold separately)			•	•	★
Other options (include with selected model number)						
HART revision configuration (requires HART Protocol output code A)⁽¹³⁾						
HR7	Configured for HART Revision 7			•	—	★
Extended product warranty						
WR3	3-year limited warranty			•	•	★
WR5	5-year limited warranty			•	•	★
Transmitter/body bolt material⁽¹⁴⁾						
G	High temperature option (850 °F [454 °C])			•	•	
Temperature sensor⁽¹⁵⁾						
T	Thermowell and RTD			•	•	★

Table 6: Rosemount 3051SFP Integral Orifice Flow Meter Ordering Information (continued)

Optional connection				
G1	DIN 19213 transmitter connection	•	•	★
Pressure testing				
P1 ⁽¹⁶⁾	Hydrostatic testing with certificate	•	•	
Special cleaning				
P2	Cleaning for special services	•	•	
PA	Cleaning per ASTM G93 level D (section 11.4)	•	•	
Material testing				
V1	Dye penetrant exam	•	•	
Material examination				
V2	Radiographic examination (available only with process connection code W1, W3, and W6)	•	•	
Flow calibration⁽¹⁷⁾				
WD	Discharge coefficient verification	•	•	
WZ	Special calibration	•	•	
Special inspection				
QC1	Visual and dimensional inspection with certificate	•	•	★
QC7	Inspection and performance certificate	•	•	★
Material traceability certification				
Q8	Material certification per EN 10204:2004 3.1	•	•	★
Code conformance⁽¹⁸⁾				
J2	ANSI/ASME B31.1	•	•	
J3	ANSI/ASME B31.3	•	•	
J4	ANSI/ASME B31.8	•	•	
Materials conformance⁽¹⁹⁾				
J5	NACE MR-0175/ISO 15156	•	•	
Country certification				
J6	European pressure directive (PED)	•	•	★
J1	Canadian registration	•	•	
Transmitter calibration certification				
Q4	Calibration data certificate for transmitter	•	•	★
QP	Calibration certificate and tamper evident seal	•	•	★
Quality certification for safety⁽²⁰⁾				
QS	Prior-use certificate of FMEDA data	•	•	★
QT ⁽²¹⁾	Safety-certified to IEC 61508 with certificate of FMEDA data	•	•	★
Product certifications				
E1	ATEX Flameproof	•	•	★
I1	ATEX Intrinsic Safety	•	•	★
IA ⁽²²⁾	ATEX FISCO Intrinsic Safety	•	•	★

Table 6: Rosemount 3051SFP Integral Orifice Flow Meter Ordering Information (continued)

N1	ATEX Type n	•	•	★
ND	ATEX Dust	•	•	★
K1	ATEX Flameproof, Intrinsic Safety, Type n, Dust (combination of E1, I1, N1, and ND)	•	•	★
E4	TIIS Flameproof	•	•	★
E5	FM Explosion-proof, Dust Ignition-proof	•	•	★
I5	FM Intrinsically Safe; Nonincendive	•	•	★
IE ⁽²²⁾	FM FISCO Intrinsic Safety	•	•	★
K5	FM Explosion-proof, Dust Ignition-proof, Intrinsically Safe, Division 2 (combination of E5 and I5)	•	•	★
E6 ⁽²³⁾	CSA Explosion-proof, Dust Ignition-proof, Division 2	•	•	★
I6	CSA Intrinsically Safe	•	•	★
IF ⁽²²⁾	CSA FISCO Intrinsic Safety	•	•	★
K6 ⁽²³⁾	CSA Explosion-proof, Dust Ignition-proof, Intrinsically Safe, Division 2 (combination of E6 and I6)	•	•	★
E7	IECEX Flameproof, Dust Ignition-proof	•	•	★
IG ⁽²²⁾	IECEX FISCO Intrinsic Safety	•	•	★
I7	IECEX Intrinsic Safety	•	•	★
K7	IECEX Flameproof, Dust Ignition-proof, Intrinsic Safety, Type n (combination of E7, I7, and N7)	•	•	★
N7	IECEX Type n	•	•	★
E3	China Flameproof	•	•	★
I3	China Intrinsic Safety	•	•	★
N3	China Type n	•	—	★
EP	Republic of Korea Flameproof	•	•	★
IP	Republic of Korea Intrinsic Safety	•	•	★
KP	Republic of Korea Flameproof, Intrinsic Safety	•	•	★
EM	Technical Regulations Customs Union (EAC) Flameproof	•	•	★
IM	Technical Regulations Customs Union (EAC) Intrinsic Safety	•	•	★
KM	Technical Regulations Customs Union (EAC) Flameproof, Intrinsic Safety	•	•	★
KG ⁽²²⁾	ATEX, FM, CSA, and IECEX FISCO Intrinsic Safety (combination of IA, IE, IF, and IG)	•	—	★
E2	INMETRO Flameproof	•	•	★
I2	INMETRO Intrinsic Safety	•	•	★
K2	INMETRO Flameproof, Intrinsic Safety	•	•	★
IB	INMETRO FISCO Intrinsic Safety	•	—	★
KA ⁽²³⁾	ATEX and CSA Flameproof, Intrinsically Safe, Division 2 (combination of E1, I1, E6, and I6)	•	•	★
KB ⁽²³⁾	FM and CSA Explosion-proof, Dust Ignition-proof, Intrinsically Safe, Division 2 (combination of E5, E6, I5, and I6)	•	•	★
KC	FM and ATEX Explosion-proof, Intrinsically Safe, Division 2 (combination of E5, E1, I5, and I1)	•	•	★
KD ⁽²³⁾	FM, CSA, and ATEX Explosion-proof, Intrinsically Safe (combination of E5, I5, E6, I6, E1, and I1)	•	•	★

Table 6: Rosemount 3051SFP Integral Orifice Flow Meter Ordering Information (continued)

Shipboard approvals⁽²⁴⁾				
SBS	American Bureau of Shipping	•	•	★
SBV	Bureau Veritas (BV) Type Approval	•	•	★
SDN	Det Norske Veritas (DNV) Type Approval	•	•	★
SLL	Lloyds Register (LR) Type Approval	•	•	★
Sensor fill fluid and O-ring options				
L1	Inert sensor fill fluid	•	•	★
L2	Graphite-filled (PTFE) O-ring	•	•	★
LA	Inert sensor fill fluid and graphite-filled (PTFE) O-ring	•	•	★
Digital display⁽²¹⁾				
M5	Plantweb LCD display (requires Plantweb housing)	•	•	★
M7 ⁽²⁵⁾⁽²⁶⁾	Remote mount LCD display and interface, Plantweb housing, no cable, SST bracket	•	—	★
M8 ⁽²⁶⁾	Remote mount LCD display and interface, Plantweb housing, 50 feet (15 m) cable, SST bracket	•	—	★
M9 ⁽²⁶⁾	Remote mount LCD display and interface, Plantweb housing, 100 feet (31 m) cable, SST bracket	•	—	★
Transient protection⁽²⁷⁾				
T1	Transient terminal block	•	•	★
Plantweb control functionality				
A01	FOUNDATION Fieldbus advanced control function block suite	•	•	★
Diagnostics suite				
D01	FOUNDATION Fieldbus diagnostics suite (Process Intelligence, Plugged Impulse Line diagnostic)	•	—	★
DA2 ⁽²⁸⁾	Advanced HART diagnostics suite (Process Intelligence, Loop Integrity, Plugged Impulse Line diagnostic, Process Alerts, Service Alerts, Variable Log, Event Log)	•	—	★
Cold temperature⁽²⁹⁾⁽³⁰⁾				
BRR	-58 °F (-50 °C) cold temperature start-up	•	•	★
Alarm limit⁽²⁹⁾				
C4	NAMUR alarm and saturation levels, high alarm	•	•	★
C5	NAMUR alarm and saturation levels, low alarm	•	•	★
C6	Custom alarm and saturation levels, high alarm	•	•	★
C7	Custom alarm and saturation levels, low alarm	•	•	★
C8	Low alarm (standard Rosemount alarm and saturation levels)	•	•	★
Hardware adjustments and ground screw				
D1 ⁽²¹⁾⁽³¹⁾⁽³²⁾	Hardware adjustments (zero, span, alarm, security)	•	—	★
D4 ⁽³³⁾	External ground screw assembly	•	•	★
DA ⁽²¹⁾⁽³¹⁾⁽³²⁾	Hardware adjustments (zero, span, alarm, security) and external ground screw assembly	•	—	★
Conduit plug				
DO	316 SST conduit plug	•	•	★

Table 6: Rosemount 3051SFP Integral Orifice Flow Meter Ordering Information (continued)

Conduit electrical connector ⁽³⁴⁾				
GE	M12, 4-pin, male connector (eurofast)	•	•	
GM	A size mini, 4-pin, male connector (minifast)	•	•	
Typical model number: 3051SFP 1 S 010 W3 S 0150 D3 1 J A 1A 3 M5				

- (1) For option code A: 4–20 mA HART only.
- (2) To improve pipe perpendicularity for gasket sealing, socket diameter is smaller than standard pipe O.D.
- (3) Required for measurement type codes 3, 4, 7, and D.
- (4) For Measurement Type codes 1, 2, 5, and 6 with DP range 1, absolute limits are 0.5 to 2000 psi (0,03 to 137,9 bar) and gage limits are –14.2 to 2000 psig (–0,98 to 137,9 bar).
- (5) Transmitter output code F is only available with Measurement type code 1, 2, 5, 6, and D.
- (6) Only intrinsically safe approval codes apply.
- (7) Only available with measurement types D and 6.
- (8) Only available with output code X.
- (9) Only available with output code A.
- (10) For details, see [Specifications](#).
- (11) Only available with differential pressure ranges 2 and 3, and silicone fill fluid.
- (12) Long-life Power Module must be shipped separately, order Power Module 701PBKKF.
- (13) Option HR7 configures the HART output to HART Revision 7. This option requires the selection of the Advanced Diagnostics (DA2) option. The device with this option can be field configured to HART Revision 5 or 7 if desired.
- (14) Not available with 1½-in. (38 mm) line size.
- (15) Thermowell material is the same as the body material.
- (16) Does not apply to process connection codes T1 and S1.
- (17) Not available for bore sizes 0010, 0014, 0020, or 0034.
- (18) Not available with DIN process connection codes D1, D2, or D3.
- (19) Materials of Construction comply with metallurgical requirements within NACE MR0175/ISO for sour oil field production environments. Environmental limits apply to certain materials. Consult latest standard for details. Selected materials also conform to NACE MR0103 for sour refining environments.
- (20) Not available with output codes F or X.
- (21) Not available with housing code 7J.
- (22) FISCO is only available with Transmitter output code F.
- (23) Not available with M20 or G½ conduit entry size.
- (24) Not available with transmitter output code F with Measurement Types 1, 2, 5, or 6.
- (25) See the Rosemount 3051S [Reference Manual](#) for cable requirements. Contact an Emerson representative for additional information.
- (26) Not available with output code F, option code DA2, or option code QT.
- (27) Not available with housing code 5A, 5J, or 7J. The T1 option is not needed with FISCO Product Certifications.
- (28) Includes hardware adjustments (option code D1) as standard. Not available with output code X or F. Only available with measurement type D.
- (29) Not available with output code F.
- (30) –58 °F (50 °C) for Measurement Type 1-7.
- (31) Not available with output code X. Only available with measurement type D.
- (32) Not available with housing codes 2E, 2F, 2G, 2M, 5A, 5J, or 7J.
- (33) This assembly is included with options EP, KP, E1, N1, K1, ND, E4, E7, K7, E3, KA, KC, KD, IA, T1, EM, and KM.
- (34) Not available with Housing code 5A, 5J, or 7J. Available with Intrinsically Safe approvals only. For FM Intrinsically Safe; Nonincendive (option code I5) or FM FISCO Intrinsically Safe (option code IE), install in accordance with Rosemount drawing 03151-1009.

Rosemount™ 3051S Electronic Remote Sensor (ERS)™ System



The Rosemount 3051S ERS System is a flexible, 2-wire 4-20 mA HART® architecture that calculates differential pressure (DP) electronically using two pressure sensors that are linked together with a non-proprietary electrical wire.

Ideal applications for the Rosemount 3051S ERS System include tall vessels and distillation columns that have traditionally required long lengths of capillary or impulse piping. When used in these types of applications, the Rosemount 3051S ERS System can deliver:

- More accurate and repeatable DP measurements
- Faster time response
- Simplified installations
- Reduced maintenance

How to order

1. Choose two Rosemount 3051S ERS Transmitter models. These may be any combination of Rosemount 3051SAM and Rosemount 3051SAL models.

Example: Rosemount 3051SAM



Coplanar



In-line

Example: Rosemount 3051SAL



Coplanar

In-line

- Decide which model will be the ERS Primary (4–20 mA loop termination and optional LCD display) and which will be the ERS Secondary. This will be specified by the “Configuration Type” code in each model number.

Example:



- A. Secondary
- B. Primary

- Specify two full model numbers per the desired configuration.

Example:

3051SAL1PG4AA1A1020DFF71DA00M5

3051SAM1ST2A2E11A2A

Rosemount™ 3051SAM Transmitter for ERS™ Applications



- Coplanar and in-line sensor module platforms
- Variety of process connections including threaded NPT, flanges, manifolds, and Rosemount 1199 Remote Seals
- Available with 15-year stability and 15-year limited warranty

Specification and selection of product materials, options, or components must be made by the purchaser of the equipment. See [Material selection](#) for more information.

The starred offerings (★) represent the most common options and should be selected for best delivery. The non-starred offerings are subject to additional delivery lead time.

Table 7: Rosemount 3051SAM Transmitter for ERS Applications Ordering Information

Model	Transmitter type				
3051SAM	Scalable ERS Measurement Transmitter				
Performance class⁽¹⁾					
1	Ultra: 0.025% span accuracy, 200:1 rangedown, 15-year stability, 15-year limited warranty				★
2	Classic: 0.035% span accuracy, 150:1 rangedown, 15-year stability				★
4	Enhanced ERS System performance, 15-year stability, 15-year limited warranty				★
Configuration type					
P	ERS - primary				★
S	ERS - secondary				★
Pressure module type		Pressure sensor type			
G	Coplanar	Gage			★
T	In-Line	Gage			★
E	In-Line	Absolute			★
A	Coplanar	Absolute			
Pressure range⁽²⁾					
	Coplanar gage	In-line gage	In-line absolute	Coplanar absolute	
1A	N/A	-14.7 to 30 psig (-1,01 to 2,06 bar)	0 to 30 psia (0 to 2,06 bar)	0 to 30 psia (0 to 2,06 bar)	★
2A	-250 to 250 inH ₂ O (-621,60 to 621,60 mbar)	-14.7 to 150 psig (-1,01 to 10,34 bar)	0 to 150 psia (0 to 10,34 bar)	0 to 150 psia (0 to 10,34 bar)	★
3A	-393 to 1000 inH ₂ O (-0,97 to 2,48 bar)	-14.7 to 800 psig (-1,01 to 55,15 bar)	0 to 800 psia (0 to 55,15 bar)	0 to 800 psia (0 to 55,15 bar)	★
4A	-14.2 to 300 psig (-0,97 to 20,68 bar)	-14.7 to 4000 psig (-1,01 to 275,79 bar)	0 to 4000 psia (0 to 275,79 bar)	0 to 4000 psia (0 to 275,79 bar)	★
5A	-14.2 to 2000 psig (-0,97 to 137,89 bar)	-14.7 to 10000 psig (-1,01 to 689,47 bar)	0 to 10000 psia (0 to 689,47 bar)	N/A	★
Isolating diaphragm					
2 ⁽³⁾ (4)	316L SST				★
3 ⁽³⁾	Alloy C-276				★
4 ⁽³⁾ (4)	Alloy 400				
5 ⁽⁴⁾ (5)	Tantalum				
6 ⁽³⁾ (4)	Gold-plated Alloy 400 (includes graphite-filled PTFE O-Ring)				
7 ⁽³⁾ (4)	Gold-plated 316L SST				

Table 7: Rosemount 3051SAM Transmitter for ERS Applications Ordering Information (continued)

Process connection			
	Coplanar module type	In-line module type	
A11 ⁽⁶⁾	Assemble to Rosemount 305 Manifold	Assemble to Rosemount 306 Manifold	★
A12 ⁽⁶⁾	Assemble to Rosemount 304 or AMF Manifold with SST traditional flange	Assemble AMF Manifold to ½-14 NPT female process connection	★
A15 ⁽⁶⁾	Assemble to Rosemount 304 or AMF manifold to SST traditional flange with alloy C-276 drain vents	N/A	★
A22 ⁽⁶⁾	Assemble to Rosemount 304 or AMF manifold to SST coplanar flange	N/A	★
B11 ⁽⁶⁾⁽⁷⁾	Assemble to one Rosemount 1199 Remote Diaphragm Seal with SST transmitter flange	Assemble to one Rosemount 1199 Remote Diaphragm	★
E11	Coplanar flange (CS), ¼-18 NPT, 316 SST drain vents	½ –14 NPT female	★
E12	Coplanar flange (SST), ¼-18 NPT, 316 SST drain vents	N/A	★
E13 ⁽³⁾	Coplanar flange (Cast C-276), ¼-18 NPT, Alloy C-276 drain vents	N/A	★
E14	Coplanar flange (Cast Alloy 400), ¼-18 NPT, Alloy 400/K-500 drain vents	N/A	★
E15 ⁽³⁾	Coplanar flange (SST), ¼-18 NPT, Alloy C-276 drain vents	N/A	★
E16 ⁽³⁾	Coplanar flange (CS), ¼-18 NPT, Alloy C-276 drain vents	N/A	★
E21	Coplanar flange (CS), RC ¼, 316 SST drain vents	N/A	★
E22	Coplanar flange (SST), RC ¼, 316 SST drain vents	N/A	★
E23 ⁽³⁾	Coplanar flange (Cast C-276), RC ¼, Alloy C-276 drain vents	N/A	★
E24	Coplanar flange (Cast Alloy 400), RC ¼, alloy 400/K-500 drain vents	N/A	★
E25 ⁽³⁾	Coplanar flange (SST), RC ¼, Alloy C-276 drain vents	N/A	★
E26 ⁽³⁾	Coplanar flange (CS), RC ¼, Alloy C-276 drain vents	N/A	★
F12	Traditional flange (SST), ¼-18 NPT, 316 SST drain vents	N/A	★
F13 ⁽³⁾	Traditional flange (Cast C-276), ¼-18 NPT, Alloy C-276 drain vents	N/A	★
F14	Traditional flange (Cast Alloy 400), ¼-18 NPT, Alloy 400/K-500 drain vents	N/A	★
F15 ⁽³⁾	Traditional flange (SST), ¼-18 NPT, Alloy C-276 drain vents	N/A	★
F22	Traditional flange (SST), RC ¼, 316 SST drain vents	N/A	★
F23 ⁽³⁾	Traditional flange (Cast C-276), RC¼, Alloy C-276 drain vents	N/A	★
F24	Traditional flange (Cast Alloy 400), RC¼, Alloy 400/K500 drain vents	N/A	★

Table 7: Rosemount 3051SAM Transmitter for ERS Applications Ordering Information (continued)

F25 ⁽³⁾	Traditional flange (SST), RC ¼, Alloy C-276 drain vents	N/A	★
F52	DIN-compliant traditional flange (SST), ¼–18 NPT, 316 drain vents, 7 to 16-in. bolting	N/A	★
G11	Vertical mount level flange (SST), 2-in. ANSI Class 150, 316 SST drain vents	G½ A DIN 16288 male (range 1–4 only)	★
G12	Vertical mount level flange (SST), 2-in. ANSI Class 300, 316 SST drain vents	N/A	★
G21	Vertical mount level flange (SST), 3-in. ANSI Class 150, 316 SST drain vents	N/A	★
G22	Vertical mount level flange (SST), 3-in. ANSI Class 300, 316 SST drain vents	N/A	★
G31	Vertical mount level flange (SST), DIN-DN 50 PN 40, 316 SST drain vents	N/A	★
G41	Vertical mount level flange (SST), DIN-DN 80 PN 40, 316 SST drain vents	N/A	★
P11	N/A	Level flange (SST), 2-in. ANSI Class 150	★
P12	N/A	Level flange (SST), 2-in. ANSI Class 300	★
P21	N/A	Level flange (SST), 3-in. ANSI Class 150	★
P22	N/A	Level flange (SST), 3-in. ANSI Class 300	★
P31	N/A	Level flange (SST), DIN-DN 50 PN 40	★
F11	Traditional flange (CS), ¼–18 NPT, 316 SST drain vents	Non-threaded instrument flange (I-Flange)	
F32	Bottom vent traditional flange (SST), ¼–18 NPT, 316 SST drain vents	N/A	
F42	Bottom vent traditional flange (SST), RC¼, 316 SST drain vents	N/A	
F62	DIN-compliant traditional flange (316 SST), ¼–18 NPT, 316 drain vents, M10 bolting	N/A	
F72	DIN-compliant traditional flange (316 SST), ¼–18 NPT, 316 drain vents, M12 bolting	N/A	
Transmitter output			
A	4–20 mA with digital signal based on HART protocol		★
Housing style		Material	Conduit entry size
Housings for ERS primary - configuration type code P			
1A	Plantweb™ housing	Aluminum	½–14 NPT
1B	Plantweb housing	Aluminum	M20 x 1.5 (CM 20)
1J	Plantweb housing	SST	½–14 NPT
1K	Plantweb housing	SST	M20 x 1.5 (CM 20)
2E	Junction box with remote display output	Aluminum	½–14 NPT
2F	Junction box with remote display output	Aluminum	M20 x 1.5 (CM 20)

Table 7: Rosemount 3051SAM Transmitter for ERS Applications Ordering Information (continued)

2M	Junction box with remote display output	SST	½–14 NPT	★
1C	Plantweb housing	Aluminum	G½	
1L	Plantweb housing	SST	G½	
2G	Junction box with remote display output	Aluminum	G½	
Housings for ERS secondary - configuration type code S				
2A	Junction box	Aluminum	½–14 NPT	★
2B	Junction box	Aluminum	M20 x 1.5 (CM 20)	★
2J	Junction box	SST	½–14 NPT	★
2C	Junction box	Aluminum	G½	
Options (include with select ed model number)				
Extended product warranty				
WR3	3-year limited warranty			★
WR5	5-year limited warranty			★
ERS connection cable				
R02	25 feet (7,62 m) of ERS cable (gray color)			
R05	50 feet (15,2 m) of ERS cable (gray color)			★
R10	100 feet (30,5 m) of ERS cable (gray color)			★
R15	150 feet (45,72 m) of ERS cable (gray color)			★
R20 ⁽⁸⁾	200 feet (60,96 m) of ERS cable (gray color)			
R22 ⁽⁹⁾	225 feet (68,58 m) of ERS cable (gray color)			
R30	300 feet (91,44 m) of ERS cable (gray color)			
R40	400 feet (121,92 m) of ERS cable (gray color)			
R50	500 feet (152,4 m) of ERS cable (gray color)			
H02	25 feet (7,62 m) of ERS cable (blue color)			
H05	50 feet (15,2 m) of ERS cable (blue color)			
H10	100 feet (30,5 m) of ERS cable (blue color)			
H15	150 feet (45,7 m) of ERS cable (blue color)			
H20 ⁽⁸⁾	200 feet (60,96 m) of ERS cable (blue color)			
H22 ⁽⁹⁾	225 feet (68,58 m) of ERS cable (blue color)			
J02	25 feet (7,62 m) of ERS armored cable			
J05	50 feet (15,2 m) of ERS armored cable			
J07	75 feet (22,8 m) of ERS armored cable			
J10	100 feet (30,5 m) of ERS armored cable			
J12 ⁽⁹⁾	125 feet (38,1 m) of ERS armored cable			

Table 7: Rosemount 3051SAM Transmitter for ERS Applications Ordering Information (continued)

Mounting bracket		
B1 ⁽⁴⁾	Traditional flange bracket, CS, 2-in. pipe	★
B2 ⁽⁴⁾	Traditional flange bracket, CS, panel	★
B3 ⁽⁴⁾	Traditional flange flat bracket, CS, 2-in. pipe	★
B4	Bracket, all SST, 2-in. pipe and panel	★
B7 ⁽⁴⁾	Traditional flange bracket, B1 with SST bolts	★
B8 ⁽⁴⁾	Traditional flange bracket, B2 with SST bolts	★
B9 ⁽⁴⁾	Traditional flange bracket, B3 with SST bolts	★
BA ⁽⁴⁾	Traditional flange bracket, B1, all SST	★
BC ⁽⁴⁾	Traditional flange bracket, B3, all SST	★
Special configuration (software)		
C1 ⁽¹⁰⁾	Customer software configuration (Configuration Data Sheet must be completed)	★
C3	Gage pressure calibration on Rosemount 3051SAM_ _A4 only	★
C4 ⁽¹⁰⁾	NAMUR alarm and saturation levels, high alarm	★
C5 ⁽¹⁰⁾	NAMUR alarm and saturation levels, low alarm	★
C6 ⁽¹⁰⁾	Custom alarm and saturation levels, high alarm (requires C1 and Configuration Data Sheet)	★
C7 ⁽¹⁰⁾	Custom alarm and saturation levels, low alarm (requires C1 and Configuration Data Sheet)	★
C8 ⁽¹⁰⁾	Low alarm (standard Rosemount alarm and saturation levels)	★
Special configuration (hardware)		
D2 ⁽¹¹⁾	¼–14 NPT flange adapters	★
D4 ⁽¹²⁾	External ground screw assembly	★
D5 ⁽¹¹⁾	Delete transmitter drain/vent valves (install plugs)	★
D7 ⁽¹¹⁾	Coplanar flange without drain/vent ports	
D9 ⁽¹¹⁾	RC ½ flange adapters	
Product certifications		
E1	ATEX Flameproof	★
I1	ATEX Intrinsic Safety	★
N1	ATEX Type n	★
K1	ATEX Flameproof and Intrinsically Safe, Type n, Dust	★
ND	ATEX Dust	★
E4	TIIS Flameproof	★
E5	FM Explosion-proof, Dust Ignition-proof	★
I5	FM Intrinsically Safe, Division 2	★
K5	FM Explosion-proof, Dust Ignition-proof, Intrinsically Safe, Division 2	★
E6 ⁽¹³⁾	CSA Explosion-proof, Dust Ignition-proof, Division 2	★
I6	CSA Intrinsically Safe	★
K6 ⁽¹³⁾	CSA Explosion-proof, Dust Ignition-proof, Intrinsically Safe, Division 2	★

Table 7: Rosemount 3051SAM Transmitter for ERS Applications Ordering Information (continued)

E7	IECEX Flameproof	★
I7	IECEX Intrinsic Safety	★
N7	IECEX Type n	★
K7	IECEX Flameproof, Intrinsic Safety, Type n	★
E2	INMETRO Flameproof	★
I2	INMETRO Intrinsically Safe	★
K2	INMETRO Flameproof, Intrinsic Safety, Type n	★
E3	China Flameproof	★
I3	China Intrinsic Safety, Dust Ignition-proof	★
EP	Korea Flameproof	★
IP	Korea Intrinsic Safety	★
KP	Korea Flameproof, Intrinsic Safety	★
EM	Technical Regulations Customs Union (EAC) Flameproof	★
IM	Technical Regulations Customs Union (EAC) Intrinsic Safety	★
KM	Technical Regulations Customs Union (EAC) Flameproof, Intrinsic Safety	★
KA ⁽¹³⁾	ATEX and CSA Flameproof, Intrinsically Safe, Division 2	★
KB ⁽¹³⁾	FM and CSA Explosion-proof, Dust Ignition-proof, Intrinsically Safe, Division 2	★
KC	FM and ATEX Explosion-proof, Intrinsically Safe, Division 2	★
KD ⁽¹³⁾	FM, CSA, and ATEX Explosion-proof, Intrinsically Safe	★
Shipboard approvals		
SBS	American Bureau of Shipping (ABS) Type Approval	★
SBV	Bureau Veritas (BV) Type Approval	★
SDN	Det Norske Veritas (DNV) Type Approval	★
SLL	Lloyds Register (LR) Type Approval	★
Calibration certification		
Q4	Calibration certificate	★
QP	Calibration certificate and tamper evident seal	★
Material traceability certification		
Q8	Material traceability certification per EN 10204 3.1	★
Quality certification for safety		
QS	Prior-use certificate of FMEDA Data	★
QT	Safety certified to IEC 61508 with certificate of FMEDA data	★
Surface finish certification		
Q16	Surface finish certification for hygienic remote seals	★
Toolkit performance reports⁽¹⁴⁾		
QZ	Remote seal system performance calculation report	★

Table 7: Rosemount 3051SAM Transmitter for ERS Applications Ordering Information (continued)

Terminal blocks ⁽¹⁵⁾		
T1	Transient terminal block	★
Sensor fill fluid ⁽¹⁶⁾		
L1	Inert sensor fill fluid	★
O-ring		
L2	Graphite-filled PTFE O-ring	★
Bolting material ⁽¹¹⁾		
L4	Austenitic 316 SST bolts	★
L5 ⁽³⁾	ASTM A 193, Grade B7M bolts	★
L6	Alloy K-500 bolts	★
L7 ⁽³⁾	ASTM A 453, Class D, Grade 660 bolts	★
L8	ASTM A 193, Class 2, Grade B8M bolts	★
Display type (ERS primary only) ⁽¹⁰⁾		
M5	Plantweb LCD display	★
M7 ⁽¹⁷⁾	Remote mount LCD display and interface, Plantweb housing, no cable, SST bracket	★
M8	Remote mount LCD display and interface, Plantweb housing, 50 feet (15,2 m) cable, SST bracket	★
M9	Remote mount LCD display and interface, Plantweb housing, 100 feet (30,5 m) cable, SST bracket	★
Pressure testing		
P1	Hydrostatic testing with certificate	
Special cleaning ⁽¹¹⁾		
P2	Cleaning for special services	
P3	Cleaning for less than 1 PPM Chlorine/Fluorine	
NACE® certificate ⁽³⁾		
Q15	Certificate of compliance to NACE MR0175/ISO 15156 for wetted materials	★
Q25	Certificate of compliance to NACE MR0103 for wetted materials	★
Typical model number: 3051SAM 1 ST 2A 2 E11 A 2A		

- (1) See “Specifications” section for more detail. See “[Specifications](#)” section for more detail. The Rosemount 3051S ERS System offers three performance class options; classic, ultra, and enhanced ERS system performance. The classic and ultra performance classes are suited to lower static pressure and stable temperature conditions. The enhanced ERS system performance class provides better performance across temperature (–40 to 185 °F) with improved performance at higher static pressure.
- (2) The pressure range should be specified based on the maximum static pressure, not differential pressure.
- (3) Materials of construction comply with metallurgical requirements highlighted within NACE MR 0175/ISO 15156 for sour oil field production environments. Environmental limits apply to certain materials. Consult latest standard for details. Selected materials also conform to NACE MR 0103 for sour refining environments. Order with Q15 or Q25 to receive a NACE certificate.
- (4) Not available with pressure sensor/module codes T or E.
- (5) Tantalum diaphragm material is only available with Pressure Sensor/Module code G.
- (6) “Assemble to” items are specified separately and require a completed model number.
- (7) Consult an Emerson representative for performance specifications.
- (8) Maximum cable distance for SIS installations. See Rosemount 3051S ERS [Reference Manual](#) for more information.
- (9) Maximum cable distance for IS (Intrinsically safe) installations. Other options may not be valid at longer distances.
- (10) Not available with Configuration Type code S.

- (11) Not available with Process Connection code A11.
- (12) This assembly is included with options E1, N1, K1, ND, E4, E7, N7, K7, E2, KA, KC, KD, K2, T1, EP, and KP.
- (13) Not available with M20 or G½ conduit entry size.
- (14) The QZ report quantifies the performance of the entire ERS system. One report is provided per ERS system. The QZ option is specified on the primary transmitter (configuration type code P).
- (15) Not available with configuration type code S.
- (16) Silicone fill fluid is standard.
- (17) See the Rosemount 3051S [Reference Manual](#) for cable requirements. Contact an Emerson representative for additional information.

Rosemount™ 3051SAL Transmitter for ERS™ Applications



- Integrated transmitter and direct mount seal in a single model number
- Variety of process connections including flanged, threaded, and hygienic remote seals
- Available with 15-year limited warranty

Specification and selection of product materials, options, or components must be made by the purchaser of the equipment. See [Material selection](#) for more information .

A Rosemount 3051SAL Scalable ERS Level Transmitter consists of three parts. First, specify the transmitter model codes found in [Table 8](#) . Then, specify a direct mount seal found here: [Diaphragm seals for Rosemount 3051SAL](#). Finish the model number by specifying all desired options from the "Options" section of [Table 8](#).

The starred offerings (★) represent the most common options and should be selected for best delivery. The non-starred offerings are subject to additional delivery lead time.

Table 8: Rosemount 3051SAL Transmitter for ERS Applications Ordering Information

Model	Transmitter type			
3051SAL	Scalable level transmitter			
Performance class⁽¹⁾				
1	Ultra: 0.055% span accuracy, 150:1 rangedown, 15-year limited warranty			★
2	Classic: 0.065% span accuracy, 150:1 rangedown			★
4	Enhanced ERS system performance, 15-year limited warranty			★
Configuration type				
P	ERS - primary			★
S	ERS - secondary			★
Pressure module type		Pressure sensor type		
G	Coplanar	Gage		★
T	In-line	Gage		★
E	In-line	Absolute		★
A	Coplanar	Absolute		
Pressure range⁽²⁾				
	Coplanar gage	In-line gage	In-line absolute	Coplanar absolute
1A	N/A	-14.7 to 30 psig (-1,01 to 2,06 bar)	0 to 30 psia (0 to 2,06 bar)	0 to 30 psia (0 to 2,06 bar) ★

Table 8: Rosemount 3051SAL Transmitter for ERS Applications Ordering Information (continued)

2A	-250 to 250 inH ₂ O (-621,60 to 621,60 mbar)	-14.7 to 150 psig (-1,01 to 10,34 bar)	0 to 150 psia (0 to 10,34 bar)	0 to 150 psia (0 to 10,34 bar)	★
3A	-393 to 1000 inH ₂ O (-0,97 to 2,48 bar)	-14.7 to 800 psig (-1,01 to 55,15 bar)	0 to 800 psia (0 to 55,15 bar)	0 to 800 psia (0 to 55,15 bar)	★
4A	-14.2 to 300 psig (-0,97 to 20,68 bar)	-14.7 to 4000 psig (-1,0 to 275,79 bar)	0 to 4000 psia (0 to 275,79 bar)	0 to 4000 psia (0 to 275,79 bar)	★
5A	-14.2 to 2000 psig (-0,97 to 137,89 bar)	-14.7 to 10000 psig (-1,01 to 689,47 bar)	0 to 10000 psia (0 to 689,47 bar)	N/A	★
Transmitter output					
A	4–20 mA with digital signal based on HART Protocol				★
Housing style		Material	Conduit entry size		
Housings for ERS primary - configuration type code P					
1A	Plantweb housing	Aluminum	½–14 NPT		★
1B	Plantweb housing	Aluminum	M20 x 1.5 (CM 20)		★
1J	Plantweb housing	SST	½–14 NPT		★
1K	Plantweb housing	SST	M20 x 1.5 (CM 20)		★
2E	Junction box with remote display output	Aluminum	½–14 NPT		★
2F	Junction box with remote display output	Aluminum	M20 x 1.5 (CM 20)		★
2M	Junction box with remote display output	SST	½–14 NPT		★
1C	Plantweb housing	Aluminum	G½		
1L	Plantweb housing	SST	G½		
2G	Junction box with remote display output	Aluminum	G½		
Housings for ERS secondary - configuration type code S					
2A	Junction box	Aluminum	½–14 NPT		★
2B	Junction box	Aluminum	M20 x 1.5 (CM 20)		★
2J	Junction box	SST	½–14 NPT		★
2C	Junction box	Aluminum	G½		
Seal system type⁽³⁾					
Coplanar pressure module type					
1	Single direct mount seal system	Welded-repairable			★
2	Single direct mount seal system	All welded			★
In-line pressure module type					
1	Single direct mount seal system	All welded			★

Table 8: Rosemount 3051SAL Transmitter for ERS Applications Ordering Information (continued)

High side connection type							
Single direct mount seal system (between transmitter and remote seal)							
0	No extension					★	
2	2-in. (50 mm) extension					★	
4	4-in. (100 mm) extension					★	
5 ⁽⁴⁾	Thermal optimizer					★	
6 ⁽⁵⁾	Thermal range expander - Silicone 200 secondary fill fluid					★	
7 ⁽⁵⁾⁽⁶⁾	Thermal range expander - SYL THERM™ XLT secondary fill fluid					★	
Low side connection type (reference pressure connection)							
Single direct mount seal system							
00	None (In-linestyle sensor)					★	
20	316L SST isolator/SST transmitter flange					★	
30	Alloy C-276 isolator/SST transmitter flange					★	
Seal fill fluid		Specific gravity at 77 °F (25 °C)	Temperature limits ⁽⁷⁾⁽⁸⁾				
			No extension	2-in. (50 mm) extension	4-in. (100 mm) extension	Thermal range expander ⁽⁹⁾	
D	Silicone 200	0.934	–49 to 401 °F (–45 to 205 °C)			N/A	★
F	Silicone 200 for vacuum applications	0.934	For use in vacuum applications below 14.7 psia (1 bar-a), refer to vapor pressure curves in Rosemount DP Level Fill Fluid Specification Technical Note .				★
J ⁽¹⁰⁾	Tri-Therm 300	0.795	–40 to 401 °F (–40 to 205 °C)	–40 to 464 °F (–40 to 240 °C)	–40 to 572 °F (–40 to 300 °C)	N/A	★
Q ⁽¹⁰⁾	Tri-Therm 300 for vacuum applications	0.795	For use in vacuum applications below 14.7 psia (1 bar-a), refer to vapor pressure curves in Rosemount DP Level Fill Fluid Specification Technical Note .				★
L	Silicone 704	1.07	32 to 401 °F (0 to 205 °C)	32 to 464 °F (0 to 240 °C)	32 to 572 °F (0 to 300 °C)	Up to 599 °F (315 °C)	★
C	Silicone 704 for vacuum applications	1.07	For use in vacuum applications below 14.7 psia (1 bar-a), refer to vapor pressure curves in Rosemount DP Level Fill Fluid Specification Technical Note .				★
R	Silicone 705	1.09	68 to 401 °F (20 to 205 °C)	68 to 464 °F (20 to 240 °C)	68 to 572 °F (20 to 300 °C)	Up to 698 °F (370 °C)	★
V	Silicone 705 for vacuum applications	1.09	For use in vacuum applications below 14.7 psia (1 bar-a), refer to vapor pressure curves in Rosemount DP Level Fill Fluid Specification Technical Note .				★
A	SYL THERM XLT	0.85	–157 to 293 °F (–105 to 145 °C)			N/A	★
H	Inert (Halocarbon)	1.85	–49 to 320 °F (–45 to 160 °C)			N/A	★
G ⁽¹⁰⁾⁽¹¹⁾	Glycerin and water	1.13	5 to 203 °F (–15 to 95 °C)			N/A	★
N ⁽¹⁰⁾	Neobee® M-20	0.94	5 to 401 °F (–15 to 205 °C)	5 to 437 °F (–15 to 225 °C)		N/A	★
p ⁽¹⁰⁾⁽¹¹⁾	Propylene glycol and water	1.02	5 to 203 °F (–15 to 95 °C)			N/A	★

Table 8: Rosemount 3051SAL Transmitter for ERS Applications Ordering Information (continued)









Y ⁽¹²⁾	UltraTherm™ 805	1.20	N/A	Up to 770 °F (410 °C)	★
Z ⁽¹²⁾	UltraTherm 805 for vacuum applications	1.20	For use in vacuum applications below 14.7 psia (1 bar-a), refer to vapor pressure curves in Rosemount DP Level Fill Fluid Specification Technical Note .		★
Continue specifying a completed model number by choosing a remote seal type below:					
Seal style		Process connections			
	FF Flush Flanged Seal	2-in./DN 50/50A 3-in./DN 80/80A 4-in./DN 100/100A			
	EF Extended Flanged Seal	3-in./DN 80/80A 4-in./DN 100/100A			
	RF Remote Flanged Seal	½-in. ¾-in. 1-in./DN 25/25A 1½-in./DN 40/40A			
	PF Pancake Seal	2-in./DN 50/50A 3-in./DN 80/80A			
	FC Flush Flanged Seal - Ring Type Joint (RTJ) gasket surface	2-in. 3-in.			
	RC Remote Flanged Seal - Ring Type Joint (RTJ) gasket surface	½-in. ¾-in. 1-in. 1½-in.			
	RT Remote Threaded Seal	¼ – 18 NPT ½ – 14 NPT ¾ – 14 NPT 1 – 11.5 NPT 1¼ – 11.5 NPT			
	SC Hygienic Tri Clamp Seal	1½-in. 2-in. 3-in.			

Table 8: Rosemount 3051SAL Transmitter for ERS Applications Ordering Information (continued)

	<i>SS Hygienic Tank Spud Seal</i>	4-in.
Options (include with selected model number)		
Extended product warranty		
WR3	3-year limited warranty	★
WR5	5-year limited warranty	★
ERS connection cable⁽¹³⁾		
R02	25 feet (7,62 m) of ERS cable (gray color)	
R05	50 feet (15,2 m) of ERS cable (gray color)	★
R10	100 feet (30,5 m) of ERS cable (gray color)	★
R15	150 feet (45,72 m) of ERS cable (gray color)	★
R20 ⁽¹⁴⁾	200 feet (60,96 m) of ERS cable (gray color)	
R22 ⁽¹⁵⁾	225 feet (68,58 m) of ERS cable (gray color)	
R30	300 feet (91,44 m) of ERS cable (gray color)	
R40	400 feet (121,92 m) of ERS cable (gray color)	
R50	500 feet (152,4 m) of ERS cable (gray color)	
H02	25 feet (7,62 m) of ERS cable (blue color)	
H05	50 feet (15,2 m) of ERS cable (blue color)	
H10	100 feet (30,5 m) of ERS cable (blue color)	
H15	150 feet (45,7 m) of ERS cable (blue color)	
H20 ⁽¹⁴⁾	200 feet (60,96 m) of ERS cable (blue color)	
H22 ⁽¹⁵⁾	225 feet (68,58 m) of ERS cable (blue color)	
J02	25 feet (7,62 m) of armored ERS cable	
J05	50 feet (15,2 m) of armored ERS cable	
J07	75 feet (22,8 m) of armored ERS cable	
J10	100 feet (30,5 m) of armored ERS cable	
J12 ⁽¹⁵⁾	125 feet (38,1 m) of armored ERS cable	
Software configuration⁽¹⁶⁾		
C1	Custom software configuration (requires Configuration Data Sheet)	★
Gage pressure calibration		
C3	Gage pressure calibration on Rosemount 3051SAL__A4 only	★
Alarm limit⁽¹⁶⁾		
C4	NAMUR alarm and saturation levels, high alarm	★
C5	NAMUR alarm and saturation levels, low alarm	★
C6	Custom alarm and saturation levels, high alarm (requires C1 and Configuration Data Sheet)	★
C7	Custom alarm and saturation levels, low alarm (requires C1 and Configuration Data Sheet)	★

Table 8: Rosemount 3051SAL Transmitter for ERS Applications Ordering Information (continued)

C8	Low alarm (standard Rosemount alarm and saturation levels)	★
Ground screw⁽¹⁷⁾		
D4	External ground screw assembly	★
Conduit plug		
DO	316 SST conduit plug	★
Product certifications		
E1	ATEX Flameproof	★
I1	ATEX Intrinsic Safety	★
N1	ATEX Type n	★
K1	ATEX Flameproof and Intrinsically Safe, Type n, Dust	★
ND	ATEX Dust	★
E4	TIIS Flameproof	★
E5	FM Explosion-proof, Dust Ignition-proof	★
I5	FM Intrinsically Safe, Division 2	★
K5	FM Explosion-proof, Dust Ignition-proof, Intrinsically Safe, Division 2	★
E6 ⁽¹⁸⁾	CSA Explosion-proof, Dust Ignition-proof, Division 2	★
I6	CSA Intrinsically Safe	★
K6 ⁽¹⁸⁾	CSA Explosion-proof, Dust Ignition-proof, Intrinsically Safe, Division 2	★
E7	IECEX Flameproof	★
I7	IECEX Intrinsic Safety	★
N7	IECEX Type n	★
K7	IECEX Flameproof, Intrinsic Safety, Type n	★
E2	INMETRO Flameproof	★
I2	INMETRO Intrinsically Safe	★
K2	INMETRO Flameproof, Intrinsic Safety, Type n	★
EP	Korea Flameproof	★
E3	China Flameproof	★
I3	China Intrinsic Safety, Dust Ignition-proof	★
IP	Korea Intrinsic Safety	★
KP	Korea Flameproof, Intrinsic Safety	★
EM	Technical Regulations Customs Union (EAC) Flameproof	★
IM	Technical Regulations Customs Union (EAC) Intrinsic Safety	★
KM	Technical Regulations Customs Union (EAC) Flameproof, Intrinsic Safety	★
KA ⁽¹⁸⁾	ATEX and CSA Flameproof, Intrinsically Safe, Division 2	★
KB ⁽¹⁸⁾	FM and CSA Explosion-proof, Dust Ignition-proof, Intrinsically Safe, Division 2	★
KC	FM and ATEX Explosion-proof, Intrinsically Safe, Division 2	★
KD ⁽¹⁸⁾	FM, CSA, and ATEX Explosion-proof, Intrinsically Safe	★

Table 8: Rosemount 3051SAL Transmitter for ERS Applications Ordering Information (continued)

Shipboard approvals		
SBS	American Bureau of Shipping (ABS) Type Approval	★
SBV	Bureau Veritas (BV) Type Approval	★
SDN	Det Norske Veritas (DNV) Type Approval	★
SLL	Lloyds Register (LR) Type Approval	★
Sensor fill fluid⁽¹⁹⁾		
L1	Inert sensor fill fluid	★
O-ring		
L2	Graphite-filled PTFE O-ring	★
Bolting material		
L4	Austenitic 316 SST bolts	★
Display type (ERS primary only)⁽¹⁶⁾		
M5	Plantweb LCD display	★
M7 ⁽²⁰⁾	Remote mount LCD display and interface, Plantweb housing, no cable, SST bracket	★
M8	Remote mount LCD display and interface, Plantweb housing, 50 feet (15,2 m) cable, SST bracket	★
M9	Remote mount LCD display and interface, Plantweb housing, 100 feet (30,5 m) cable, SST bracket	★
Pressure testing		
P1	Hydrostatic testing with certificate	
Special cleaning		
P2	Cleaning for special services	
P3	Cleaning for Less than 1 PPM Chlorine/Fluorine	
Calibration certification		
Q4	Calibration certificate	★
QP	Calibration certificate with tamper evident seal	★
Material traceability certification		
Q8	Material traceability certification per EN 10204 3.1	★
Quality certification for safety		
QS	Prior-use certificate of FMEDA Data	★
QT	Safety certified to IEC 61508 with certificate of FMEDA data	★
Toolkit performance reports⁽²¹⁾		
QZ	Remote seal system performance calculation report	★
Transient protection⁽¹⁶⁾		
T1	Transient terminal block	★
NACE[®] certificate⁽²²⁾		
Q15	Certificate of compliance to NACE MR0175/ISO 15156 for wetted materials	★
Q25	Certificate of compliance to NACE MR0103 for wetted materials	★
Typical model number: 3051SAL 1 P G 4A A 1A 1 0 20 D FF 7 1 DA 0 0 M5		

- (1) See "Specifications" section for more detail. The Rosemount 3051S ERS System offer three performance class options; classic, ultra, and enhanced ERS system performance. The classic and ultra performance classes are suited to lower static pressure and stable temperature conditions. The enhanced ERS system performance class provides better performance across temperature (-40 to 185 °F) with improved performance at higher static pressure.
- (2) Not suitable for vacuum applications.
- (3) See "Seal system type in Rosemount DP Level [Product Data Sheet](#) for more detail.
- (4) Maximum working pressure (MWP) of the Thermal Optimizer is 4000 psi (275 bar).
- (5) Maximum working pressure (MWP) of the thermal range expander is 3750 psi (258,6 bar).
- (6) Thermal range expander with SYL THERM XLT secondary fill fluid is not recommended for use in vacuum applications below 6 psia (400 mbar-a).
- (7) At ambient pressure of 14.7 psia (1 bar-a) and ambient temperature of 70 °F (21 °C). Temperature limits are reduced in vacuum service and may be limited by seal selection.
- (8) Due to heat transfer to the transmitter, the maximum process temperature of the transmitter will be de-rated if ambient or process temperatures exceed 185 °F (85 °C). Consult Instrument Toolkit to verify the application.
- (9) For complete process and ambient temperature limits, see thermal range expander temperature operating range.
- (10) This is a food grade fill fluid.
- (11) Not suitable for vacuum applications.
- (12) Only available with Thermal Range Expander.
- (13) The pressure range should be specified based on the maximum static pressure, not differential pressure.
- (14) Maximum cable distance for SIS installations. See "Safety Instrumented Systems (SIS) Certification" section of Rosemount 3051S ERS [Reference Manual](#) for more information.
- (15) Maximum cable distance for IS (Intrinsically safe) installations. Other options may not be valid at longer distances.
- (16) Not available with configuration type code S.
- (17) This assembly is included with options EP, KP, E1, N1, K1, ND, E4, E7, N7, K7, E2, KA, KC, KD, K2, T1, E3, EM, KM.
- (18) Not available with M20 or G½ conduit entry size.
- (19) Silicone fill fluid is standard.
- (20) See the Rosemount 3051S [Reference Manual](#) for cable requirements. Contact an Emerson representative for additional information.
- (21) The QZ report quantifies the performance of the entire ERS system. One report is provided per ERS system. The QZ option is specified on the primary transmitter (configuration type code P).
- (22) Materials of construction comply with metallurgical requirements highlighted within NACE MR 0175/ISO 15156 for sour oil field production environments. Environmental limits apply to certain materials. Consult latest standard for details. Selected materials also conform to NACE MR 0103 for sour refining environments.

Rosemount™ 3051S Scalable™ Level Transmitter

Rosemount 3051S Scalable Level Transmitters combine the features and benefits of a high-performance Rosemount 3051S with the durability and reliability of diaphragm seals all in a single model number.



Rosemount 3051SAL In-line with “FF” Flanged Seal

Rosemount 3051SAL Coplanar™ with “SS” Hygienic Tank Spud Seal

Rosemount 3051SAL Tuned-System™ Assembly with Thermal Range Expander

Rosemount 3051SAL Balanced System

Product features and capabilities include:

- Variety of process connections including flanged, threaded, and hygienic seals
- Quantified performance for the entire transmitter/seal assembly (QZ option)
- HART®, FOUNDATION™ Fieldbus, and wireless protocols

Additional information: [Specifications](#), [Rosemount 3051S/3051SFx/3051S-ERS](#), [Dimensional drawings](#)

Rosemount 3051SAL Scalable Level Transmitter

Specification and selection of product materials, options, or components must be made by the purchaser of the equipment. See [Material selection](#) for more information.

A Rosemount 3051SAL Transmitter consists of three parts. First, specify the transmitter model codes found in [Table 9](#). Then, specify a direct mount seal found here: [Diaphragm seals for Rosemount 3051SAL](#). Finish the model number by specifying all desired options from the "Options" section of [Table 9](#).

The starred offerings (★) represent the most common options and should be selected for best delivery. The non-starred offerings are subject to additional delivery lead time.

Table 9: Rosemount 3051SAL Scalable Level Transmitter Ordering Information

Model	Transmitter type	
3051SAL	Scalable level transmitter	
Performance class⁽¹⁾		
1	Ultra: 0.055% span accuracy, 150:1 rangedown, 15-year limited warranty	★
2	Classic: 0.065% span accuracy, 150:1 rangedown	★

Table 9: Rosemount 3051SAL Scalable Level Transmitter Ordering Information (continued)

Configuration type						
C	Liquid level transmitter					★
Pressure module type						
D	Coplanar	Differential				★
G	Coplanar	Gage				★
T	In-line	Gage				★
E	In-line	Absolute				★
A	Coplanar	Absolute				
Pressure range						
	Coplanar DP	Coplanar Gage	In-line Gage	In-line Absolute	Coplanar Absolute	
1A	N/A	N/A	-14.7 to 30 psig (-1,01 to 2,06 bar)	0 to 30 psia (0 to 2,06 bar)	0 to 30 psia (0 to 2,06 bar)	★
2A	-250 to 250 inH ₂ O (-621,60 to 621,60 mbar)	-250 to 250 inH ₂ O (-621,60 to 621,60 mbar)	-14.7 to 150 psig (-1,01 to 10,34 bar)	0 to 150 psia (0 to 10,34 bar)	0 to 150 psia (0 to 10,34 bar)	★
3A	-1000 to 1000 inH ₂ O (-2,48 to 2,48 bar)	-393 to 1000 inH ₂ O (-0,97 to 2,48 bar)	-14.7 to 800 psig (-1,01 to 55,15 bar)	0 to 800 psia (0 to 55,15 bar)	0 to 800 psia (0 to 55,15 bar)	★
4A	-300 to 300 psi (-20,68 to 20,68 bar)	-14.2 to 300 psig (-0,97 to 20,68 bar)	-14.7 to 4000 psig (-1,01 to 275,79 bar)	0 to 4000 psia (0 to 275,79 bar)	0 to 4000 psia (0 to 275,79 bar)	★
5A	-2000 to 2000 psi (-137,89 to 137,89 bar)	-14.2 to 2000 psig (-0,97 to 137,89 bar)	-14.7 to 10000 psig (-1,01 to 689,47 bar)	0 to 10000 psia (0 to 689,47 bar)	N/A	★
Transmitter output						
A	4–20 mA with digital signal based on HART protocol					★
F ⁽²⁾	FOUNDATION Fieldbus protocol					★
X ⁽³⁾	Wireless (requires wireless options and wireless Plantweb housing)					★
Housing style		Material		Conduit entry		
1A	Plantweb housing	Aluminum		½–14 NPT		★
1B	Plantweb housing	Aluminum		M20 x 1.5		★
1J	Plantweb housing	SST		½–14 NPT		★
1K	Plantweb housing	SST		M20 x 1.5		★
2A	Junction box housing	Aluminum		½–14 NPT		★
2B	Junction box housing	Aluminum		M20 x 1.5		★

Table 9: Rosemount 3051SAL Scalable Level Transmitter Ordering Information (continued)

2E	Junction box with output for remote interface	Aluminum	½–14 NPT	★	
2F	Junction box with output for remote interface	Aluminum	M20 x 1.5	★	
2J	Junction box housing	SST	½–14 NPT	★	
5A ⁽⁴⁾	Wireless Plantweb housing	Aluminum	½–14 NPT	★	
5J ⁽⁴⁾	Wireless Plantweb housing	SST	½–14 NPT	★	
7J ⁽⁵⁾	Quick connect (a size mini, 4-pin male termination)	SST	N/A	★	
1C	Plantweb housing	Aluminum	G½		
1L	Plantweb housing	316L SST	G½		
2C	Junction box housing	Aluminum	G½		
2G	Junction box with output for remote interface	Aluminum	G½		
Seal system type					
Coplanar pressure module type			In-line pressure module type		
1	Direct mount single seal system	Welded-repairable	Direct mount single seal system	Welded-repairable	★
2	Direct mount single seal system	All welded	N/A	N/A	★
3 ⁽⁶⁾	Tuned-system assembly - one direct mount and one remote mount seal with capillary	Welded-repairable	N/A	N/A	★
4 ⁽⁶⁾	Tuned-system assembly - one direct mount and one remote mount seal with capillary	All welded	N/A	N/A	★
5 ⁽⁶⁾	Balanced system - two remote mount seals with equal lengths of capillary	Welded-repairable	N/A	N/A	★
6 ⁽⁶⁾	Balanced system - two remote mount seals with equal lengths of capillary	All welded	N/A	N/A	★
7	Remote mount single seal system with capillary - 316L low side transmitter isolator	Welded-repairable	Remote mount single seal system with capillary	All welded	★
8	Remote mount single seal system with capillary - 316L low side transmitter isolator	All welded	N/A	N/A	★
9	Remote mount single seal system with capillary - Alloy C-276 low side transmitter isolator	Welded-repairable	N/A	N/A	★
A	Remote mount single seal system with capillary - Alloy C-276 low side transmitter isolator	All welded	N/A	N/A	★

Table 9: Rosemount 3051SAL Scalable Level Transmitter Ordering Information (continued)

High side connection type (select based on seal system type chosen)							
	Single seal system			Dual seal system			
	Direct mount		Remote mount with capillary		Tuned-system assembly	Balanced system	
	Coplanar	In-line	Coplanar	In-line	Coplanar	Coplanar	
0	No extension		Standard	Standard	No extension/Standard	Standard	★
2	2-in. (50 mm) extension	N/A	N/A	N/A	2-in. (50 mm) extension	N/A	★
4	4-in. (100 mm) extension	4-in. (100 mm) extension ⁽⁷⁾	N/A	N/A	4-in. (100 mm) extension	N/A	★
6 ⁽⁸⁾	Thermal Range Expander - Silicone 200 secondary fill		Thermal Range Expander - Silicone 200 secondary fill fluid single capillary		Thermal Range Expander - Silicone 200 secondary fill with low side capillary		★
7 ⁽⁸⁾	Thermal Range Expander - SYLTHERM™ XLT secondary fill fluid		Thermal Range Expander - SYLTHERM XLT secondary fill fluid single capillary		Thermal Range Expander - SYLTHERM XLT secondary fill with low side capillary		★
Low side connection type or capillary I.D.							
	Material for low side reference connection		Capillary I.D.				
	Direct mount		Remote mount with capillary		Tuned-system assembly	Balanced system	
	Coplanar	In-line	Coplanar or In-line		Coplanar	Coplanar	
0	N/A	No reference connection	N/A		N/A	N/A	★
1 ⁽⁹⁾⁽¹⁰⁾	Assemble to one Rosemount 1199 remote seal	N/A	N/A		N/A	N/A	★
2	316L SST isolator and SST transmitter flange	N/A	N/A		N/A	N/A	★
3	Alloy C-276 isolator and SST transmitter flange	N/A	N/A		N/A	N/A	★
B	N/A	N/A	0.03-in. (0,711 mm) ID capillary		0.03-in. (0,711 mm) ID capillary	0.03-in. (0,711 mm) ID capillary	★

Table 9: Rosemount 3051SAL Scalable Level Transmitter Ordering Information (continued)

C	N/A	N/A	0.04-in. (1,092 mm) ID capillary	0.04-in. (1,092 mm) ID capillary	0.04-in. (1,092 mm) ID capillary	★
D	N/A	N/A	0.075-in. (1,905 mm) ID capillary	0.075-in. (1,905 mm) ID capillary	0.075-in. (1,905 mm) ID capillary	★
E ⁽¹¹⁾	N/A	N/A	0.03-in. (0,711 mm) ID capillary, PVC coated with closed end	0.03-in. (0,711 mm) ID capillary, PVC coated with closed end	0.03-in. (0,711 mm) ID capillary, PVC coated with closed end	★
F ⁽¹¹⁾	N/A	N/A	0.04-in. (1,092 mm) ID capillary, PVC coated with closed end	0.04-in. (1,092 mm) ID capillary, PVC coated with closed end	0.04-in. (1,092 mm) ID capillary, PVC coated with closed end	★
G ⁽¹¹⁾	N/A	N/A	0.075-in. (1,905 mm) ID capillary, PVC coated with closed end	0.075-in. (1,905 mm) ID capillary, PVC coated with closed end	0.075-in. (1,905 mm) ID capillary, PVC coated with closed end	★
Capillary length⁽¹²⁾						
0	No capillary (required for direct mount single seal system)					★
A	1 foot (0,3 m)					★
B	5 feet (1,5 m)					★
C	10 feet (3,0 m)					★
D	15 feet (4,5 m)					★
E	20 feet (6,1 m)					★
F	25 feet (7,6 m)					★
G	30 feet (9,1 m)					★
H	35 feet (10,7 m)					★
J	40 feet (12,2 m)					★
K	45 feet (13,7 m)					★
L	50 feet (15,2 m)					★
M	1.6 feet (0,5 m)					★
N	3.3 feet (1,0 m)					★
P	4.9 feet (1,5 m)					★
R	6.6 feet (2,0 m)					★
T	8.2 feet (2,5 m)					★

Table 9: Rosemount 3051SAL Scalable Level Transmitter Ordering Information (continued)

U	9.8 feet (3,0 m)							★	
V	11.5 feet (3,5 m)							★	
W	13.1 feet (4,0 m)							★	
Y	16.4 feet (5,0 m)							★	
Z	19.7 feet (6,0 m)							★	
1	23 feet (7,0 m)							★	
2	26.2 feet (8,0 m)							★	
3	29.5 feet (9,0 m)							★	
4	32.8 feet (10,0 m)							★	
5	36.1 feet (11,0 m)							★	
6	39.4 feet (12,0 m)							★	
7	42.6 feet (13,0 m)							★	
8	45.9 feet (14,0 m)							★	
9	49.2 feet (15,0 m)							★	
Seal fill fluid	Specific gravity at 77 °F (25 °C)	Temperature limits ⁽¹³⁾⁽¹⁴⁾					Thermal range expander ⁽¹⁵⁾	Capillary	
		No extension	2-in. (50 mm) extension	4-in. (100 mm) extension					
D	Silicone 200	0.934	-49 to 401 °F (-45 to 205 °C)			N/A	-49 to 401 °F (-45 to 205 °C)	★	
F	Silicone 200 for vacuum applications	0.934	For use in vacuum applications below 14.7 psia (1 bar-a), refer to vapor pressure curves in Rosemount DP Level Fill Fluid Specification Technical Note .					★	
J ⁽¹⁶⁾	Tri-Therm 300	0.795	-40 to 401 °F (-40 to 205 °C)	-40 to 464 °F (-40 to 240 °C)	-40 to 572 °F (-40 to 300 °C)	N/A	-40 to 572 °F (-40 to 300 °C)	★	
Q ⁽¹⁶⁾	Tri-Therm 300 for vacuum applications	0.795	For use in vacuum applications below 14.7 psia (1 bar-a), refer to vapor pressure curves in Rosemount DP Level Fill Fluid Specification Technical Note .					★	
L	Silicone 704	1.07	32 to 401 °F (0 to 205 °C)	32 to 464 °F (0 to 240 °C)	32 to 572 °F (0 to 300 °C)	Up to 599 °F (315 °C)	-32 to 599 °F (0 to 315 °C)	★	
C	Silicone 704 for vacuum applications	1.07	For use in vacuum applications below 14.7 psia (1 bar-a), refer to vapor pressure curves in Rosemount DP Level Fill Fluid Specification Technical Note .					★	
R	Silicone 705	1.09	68 to 401 °F (20 to 205 °C)	68 to 464 °F (20 to 240 °C)	68 to 572 °F (20 to 300 °C)	Up to 698 °F (370 °C)	68 to 698 °F (20 to 370 °C)	★	

Table 9: Rosemount 3051SAL Scalable Level Transmitter Ordering Information (continued)

V	Silicone 705 for vacuum applications	1.09	For use in vacuum applications below 14.7 psia (1 bar-a), refer to vapor pressure curves in Rosemount DP Level Fill Fluid Specification Technical Note .			★	
Y ⁽¹⁷⁾	UltraTherm™ 805	1.20	N/A	Up to 770 °F (410 °C)	N/A	★	
Z ⁽¹⁷⁾	UltraTherm 805 for vacuum applications	1.20	For use in vacuum applications below 14.7 psia (1 bar-a), refer to vapor pressure curves in Rosemount DP Level Fill Fluid Specification Technical Note .			★	
A	SYLTHERM XLT	0.85	-157 to 293 °F (-105 to 145 °C)	N/A	-157 to 293 °F (-105 to 145 °C)	★	
H	Inert (Halocarbon)	1.85	-49 to 320 °F (-45 to 160 °C)	N/A	-49 to 320 °F (-45 to 160 °C)	★	
N ⁽¹⁶⁾	Neobee® M-20	0.94	5 to 401 °F (-15 to 205 °C)	5 to 437 °F (-15 to 225 °C)	N/A	5 to 437 °F (-15 to 225 °C)	★
G ⁽¹⁰⁾⁽¹⁶⁾	Glycerin and water	1.13	5 to 203 °F (-15 to 95 °C)		N/A	5 to 437 °F (-15 to 225 °C)	★
P ⁽¹⁰⁾⁽¹⁶⁾	Propylene glycol and water	1.02	5 to 203 °F (-15 to 95 °C)		N/A	5 to 203 °F (-15 to 95 °C)	★

Continue specifying a completed model number by choosing a remote seal type below:





Seal style		Process connections
	FF Flush Flanged Seal	2-in./DN 50/50A 3-in./DN 80/80A 4 in./DN 100/100A
	EF Extended Flanged Seal	3-in./DN 80/80A 4-in./DN 100/100A
	PF Pancake Seal	½-in. ¾-in. 1-in./DN 25/25A 1½-in./DN 40/40A
	PF Pancake Seal	2-in./DN 50/50A 3-in./DN 80/80A

Table 9: Rosemount 3051SAL Scalable Level Transmitter Ordering Information (continued)





	<i>FC Flush Flanged Seal - Ring Type Joint (RTJ) gasket surface</i>	2-in. 3-in.
	<i>RC Remote Flanged Seal - Ring Type Joint (RTJ) gasket surface</i>	½-in. ¾-in. 1 in. 1½-in.
	<i>RT Remote Threaded Seal</i>	¼-18 NPT ½-14 NPT ¾-14 NPT 1-11.5 NPT 1¼-11.5 NPT
	<i>SC Hygienic Tri Clamp Seal</i>	1½-in. 2-in. 3-in.
	<i>SS Hygienic Tank Spud Seal</i>	4-in.
Wireless options (requires option code X and wireless Plantweb housing)		
Update rate⁽⁴⁾		
WA	User configurable update rate	★
Operating frequency and protocol		
3	2.4 GHz DSSS, IEC 62591 (<i>WirelessHART</i>)	★
Omni-directional wireless antenna		
WK ⁽⁴⁾	External antenna	★
WM ⁽⁴⁾	Extended range, external antenna	★
WN	High-gain, remote antenna	
SmartPower⁽¹⁸⁾⁽¹⁹⁾		
1	Adapter for Black Power Module (I.S. Power Module sold separately)	★
Other options (include with selected model number)		
HART Revision configuration (requires HART Protocol output code A)⁽²⁰⁾		
HR7	Configured for HART Revision 7	★

Table 9: Rosemount 3051SAL Scalable Level Transmitter Ordering Information (continued)

Extended product warranty		
WR3	3-year limited warranty	★
WR5	5-year limited warranty	★
Plantweb control functionality⁽¹⁹⁾⁽²¹⁾⁽²²⁾		
A01	FOUNDATION Fieldbus advanced control function block suite	★
Diagnostics suite		
D01 ⁽¹⁹⁾⁽²¹⁾	FOUNDATION Fieldbus diagnostics suite (Process Intelligence, Plugged Impulse Line diagnostic)	★
DA2 ⁽²³⁾	Advanced HART diagnostics suite (Process Intelligence, Loop Integrity, Plugged Impulse Line diagnostic, Process Alerts, Service Alerts, Variable Log, Event Log)	★
Mounting bracket		
B4	Bracket, all SST, 2-in. pipe panel	★
BE	Bracket, 316 SST, B4-style with 316 SST bolting	★
Software configuration⁽²⁴⁾		
C1	Custom software configuration (requires Configuration Data Sheet)	★
Gage pressure calibration		
C3	Gage pressure calibration on Rosemount 3051SAL_ _A4 only	★
Alarm limit⁽²¹⁾⁽²⁴⁾		
C4	NAMUR alarm and saturation levels, high alarm	★
C5	NAMUR alarm and saturation levels, low alarm	★
C6	Custom alarm and saturation signal levels, high alarm (requires C1 and Configuration Data Sheet)	★
C7	Custom alarm and saturation signal levels, low alarm (requires C1 and Configuration Data Sheet)	★
C8	Low alarm (standard Rosemount alarm and saturation levels)	★
Hardware adjustments⁽²⁴⁾⁽²⁵⁾⁽²⁶⁾		
D1	Hardware adjustments (zero, span, alarm, security)	★
Flange adapter		
D2	½–14 NPT flange adapter	★
D9	RC½ SST flange adapter	
Ground screw⁽²⁷⁾		
D4	External ground screw assembly	★
Drain/vent valve		
D5	Delete transmitter drain/vent valves (install plugs)	★
Conduit plug⁽²⁸⁾		
DO	316 SST conduit plug	★
Product certifications⁽²⁹⁾		
E1	ATEX Flameproof	★
I1	ATEX Intrinsic Safety	★
IA	ATEX FISCO Intrinsic Safety (FOUNDATION Fieldbus protocol only)	★

Table 9: Rosemount 3051SAL Scalable Level Transmitter Ordering Information (continued)

N1	ATEX Type n	★
K1	ATEX Flameproof, Intrinsic Safety, Type n, Dust	★
ND	ATEX Dust	★
E4	TIIS Flameproof	★
E5	FM Explosion-proof, Dust Ignition-proof	★
I5	FM Intrinsically Safe; Nonincendive	★
IE	FM FISCO Intrinsically Safe (FOUNDATION Fieldbus protocol only)	★
K5	FM Explosion-proof, Dust Ignition-proof, Intrinsically Safe, Division 2	★
E6 ⁽³⁰⁾	CSA Explosion-proof, Dust Ignition-proof, Division 2	★
I6	CSA Intrinsically Safe	★
IF	CSA FISCO Intrinsically Safe (FOUNDATION Fieldbus protocol only)	★
K6 ⁽³⁰⁾	CSA Explosion-proof, Dust Ignition-proof, Intrinsically Safe, Division 2	★
D3 ⁽³¹⁾	Measurement Canada Accuracy Approval	★
E7	IECEX Flameproof, Dust Ignition-proof	★
I7	IECEX Intrinsic Safety	★
IG	IECEX FISCO Intrinsic Safety (FOUNDATION Fieldbus protocol only)	★
N7	IECEX Type n	★
K7	IECEX Flameproof, Dust Ignition-proof, Intrinsic Safety, Type n	★
E2	INMETRO Flameproof	★
I2	INMETRO Intrinsic Safety	★
IB	INMETRO FISCO Intrinsic Safety	★
K2	INMETRO Flameproof, Intrinsic Safety	★
E3	China Flameproof	★
I3	China Intrinsic Safety, Dust Ignition-proof	★
EP	Korea Flameproof	★
IP	Korea Intrinsic Safety	★
KP	Korea Flameproof, Intrinsic Safety	★
EM	Technical Regulations Customs Union (EAC) Flameproof	★
IM	Technical Regulations Customs Union (EAC) Intrinsic Safety	★
KM	Technical Regulations Customs Union (EAC) Flameproof, Intrinsic Safety	★
KA ⁽³⁰⁾	ATEX and CSA Flameproof, Intrinsically Safe, Division 2	★
KB ⁽³⁰⁾	FM and CSA Explosion-proof, Dust Ignition-proof, Intrinsically Safe, Division 2	★
KC	FM and ATEX Explosion-proof, Intrinsically Safe, Division 2	★
KD ⁽³⁰⁾	FM, CSA, and ATEX Explosion-proof, Intrinsically Safe	★
Shipboard approvals		
SBS	American Bureau of Shipping (ABS) Type Approval	★
SBV	Bureau Veritas (BV) Type Approval	★

Table 9: Rosemount 3051SAL Scalable Level Transmitter Ordering Information (continued)

SDN	Det Norske Veritas (DNV) Type Approval	★
SLL	Lloyds Register (LR) Type Approval	★
Stainless steel tagging		
Y2	316 SST nameplate, top tag, wire-on tag(s), and fasteners	★
Sensor fill fluid⁽³²⁾		
L1	Inert sensor fill fluid	★
O-ring		
L2	Graphite-filled PTFE O-ring	★
Bolting material		
L4	Austenitic 316 SST bolts	★
L5 ⁽³³⁾	ASTM A193, Grade B7M bolts	★
L6	Alloy K-500 bolts	★
L7 ⁽³³⁾	ASTM A453, Class D, Grade 660 bolts	★
L8	ASTM A193, Class 2, Grade B8M bolts	★
Display type⁽²¹⁾⁽³⁴⁾⁽³⁵⁾		
M5 ⁽³⁵⁾	Plantweb LCD display	★
M7	Remote mount LCD display and interface, Plantweb housing, no cable, SST bracket	★
M8	Remote mount LCD display and interface, Plantweb housing, 50 feet (15 m) cable, SST bracket	★
M9	Remote mount LCD display and interface, Plantweb housing, 100 feet (31 m) cable, SST bracket	★
Pressure testing		
P1	Hydrostatic testing with certificate	
Special cleaning		
P2	Cleaning for special services	
P3	Cleaning for special services with testing for <1PPM chlorine/fluorine	
Calibration certification		
Q4	Calibration certificate	★
QP	Calibration certificate and tamper evident seal	★
Material traceability certification		
Q8	Material traceability certification per EN 10204 3.1	★
Quality certification for safety		
QS ⁽²¹⁾⁽²⁴⁾	Prior-use certificate of FMEDA Data	★
QT ⁽³⁶⁾	Safety-certified to IEC 61508 with certificate of FMEDA data	★
Toolkit performance reports		
QZ	Remote seal system performance calculation report	★
Transient protection⁽³⁷⁾⁽³⁸⁾		
T1	Transient terminal block	★

Table 9: Rosemount 3051SAL Scalable Level Transmitter Ordering Information (continued)

Conduit electrical connector ⁽³⁹⁾		
GE	M12, 4-pin, male connector (eurofast)	★
GM	A size mini, 4-pin, male connector (minifast)	★
NACE certificate ⁽³³⁾		
Q15	Certificate of compliance to NACE MR0175/ISO 15156 for wetted materials	★
Q25	Certificate of compliance to NACE MR0103 for wetted materials	★
Typical model number: 3051SAL 1 C G 2A A 1A 10 20 D FF G 1 DA 0 0		

- (1) For details, see [Specifications](#). The Rosemount 3051S ERS System offers three performance class options; Classic, Ultra, and Enhanced ERS System Performance. The Classic and Ultra performance classes are suited to lower static pressure and stable temperature conditions. The Enhanced ERS System Performance class provides better performance across temperature (–40 to 185 °F) with improved performance at higher static pressure.
- (2) Requires Plantweb housing.
- (3) Only intrinsically safe approval codes apply.
- (4) Only available with output code X.
- (5) Available with output code A only. Available approvals are FM Intrinsically Safe; Nonincendive (option code I5), CSA Intrinsically Safe (option code I6), ATEX Intrinsic Safety (option code I1), or IECEx Intrinsic Safety (option code I7). Contact an Emerson Process Management representative for additional information.
- (6) Low side seal identical to high side seal.
- (7) Maximum working pressure is 4000 psi (275 bar).
- (8) Maximum working pressure (MWP) of the Thermal Range Expander is 3750 psi (258,6 bar).
- (9) Requires separate Rosemount 1199 model number to be selected. With option code 1, user must select Seal Location Option code M (low side of transmitter) in the Rosemount 1199 Remote Mount Seal System Model.
- (10) Not suitable for vacuum applications.
- (11) PVC coating should not be exposed to temperatures above 212 °F (100 °C) to avoid possibility of thermal breakdown.
- (12) Capillary length applies to both high and low side for balanced systems. Applies to low side only for tuned-system assemblies. Applies to high side only for remote mount single seal systems with capillary.
- (13) At ambient pressure of 14.7 psia (1 bar-a) and ambient temperature of 70 °F (21 °C). Temperature limits are reduced in vacuum service and may be limited by seal selection.
- (14) Due to heat transfer to the transmitter, the maximum process temperature of the transmitter will be de-rated if ambient or process temperatures exceed 185 °F (85 °C). Consult Instrument Toolkit to verify the application.
- (15) For complete process and ambient temperature limits, see [Thermal Range Expander temperature operating range](#).
- (16) This is a food grade fill fluid.
- (17) Only available with Thermal Range Expander.
- (18) Long-life power module must be shipped separately, order power module 701PBKKF.
- (19) Not available with output code A.
- (20) Option HR7 configures the HART output to HART Revision 7. This option requires the selection of the Advanced Diagnostics (DA2) option. The device with this option can be field configured to HART Revision 5 or 7 if desired.
- (21) Not available with output code X.
- (22) With option code 10, user must select seal location option code M in Rosemount DP Level PDS.
- (23) Requires Plantweb housing and output code A. Includes hardware adjustments as standard.
- (24) Not available with output code F.
- (25) Not available with output code F, option code DA2, or option code QT.
- (26) Not available with housing style codes 2E, 2F, 2G, 2M, 5A, 5J, or 7J.
- (27) This assembly is included with options EP, KP, E1, N1, K1, ND, E4, E7, N7, K7, E2, E3, KA, KC, KD. IA, IB, IE. IF, IG, K2, T1, EM, and KM.
- (28) Transmitter is shipped with 316 SST conduit plug (uninstalled) in place of carbon steel conduit plug.
- (29) Valid when SuperModule™ Platform and housing have equivalent approvals.
- (30) Not available with M20 or G½ conduit entry size.
- (31) Requires Plantweb housing and hardware adjustments option code D1. Limited availability depending on transmitter type and range. Contact an Emerson representative for additional information.
- (32) Silicone fill fluid is standard.

- (33) Materials of construction comply with metallurgical requirements highlighted within NACE MR0175/ISO 15156 for sour oil field production environments. Environmental limits apply to certain materials. Consult latest standard for details. Selected materials also conform to NACE MR0103 for sour refining environments. Order with Q15 or Q25 to receive a NACE certificate.
- (34) Not available with housing code 01 or 7J.
- (35) See the Rosemount 3051S [Reference Manual](#) for cable requirements. Contact an Emerson representative for additional information.
- (36) Not available with output code F or X. Not available with housing code 7J.
- (37) Not available with Housing code 5A, 5J, or 7J.
- (38) The T1 option is not needed with FISCO Product Certifications; transient protection is included in the FISCO product certification codes IA, IB, IE, IF, and IG.
- (39) Not available with Housing code 5A, 5J, or 7J. Available with Intrinsically Safe approvals only. For FM Intrinsically Safe; Nonincendive (option code I5) or FM FISCO Intrinsically Safe (option code IE), install in accordance with Rosemount drawing 03151-1009.

Diaphragm seals for Rosemount 3051SAL

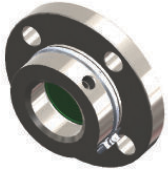

Flush Flanged (FF) Seal

- Most common seal
- Good for use in general applications
- Easy installation on flanged connections ranging from 2-in. (DN 50) to 4-in. (DN 100)

Specification and selection of product materials, options, or components must be made by the purchaser of the equipment. See [Material selection](#) for more information .

The starred offerings (★) represent the most common options and should be selected for best delivery. The non-starred offerings are subject to additional delivery lead time.

Table 10: Flush Flanged (FF) Seal Ordering Information

Model	Process connection			
FF	Flush flanged seal			
Process connection size				
	ANSI/ASME B16.5	EN 1092-1/GOST 33259-15	JIS B2238	
G	2-in.	DN 50	50 A	★
7	3-in.	N/A	80 A	★
J	N/A	DN 80	N/A	★
9	4-in.	DN 100	100 A	★
Flange/pressure rating				
1	ANSI/ASME B16.5 Class 150			★
2	ANSI/ASME B16.5 Class 300			★
4	ANSI/ASME B16.5 Class 600			★
G	PN 40 per EN 1092-1			★
5	ANSI/ASME B16.5 Class 900			
6	ANSI/ASME B16.5 Class 1500			

Table 10: Flush Flanged (FF) Seal Ordering Information (continued)

7	ANSI/ASME B16.5 Class 2500			
H	PN 63 per EN 1092-1			
J	PN 100 per EN 1092-1			
A	10K per JIS B2238			
B	20K per JIS B2238			
D	40K per JIS B2238			
E	PN 10/16 per EN 1092-1, available with DN 100 only			
Materials of construction				
	Isolating diaphragm	Upper housing	Flange	
CA	316L SST	316L SST	CS	★
DA	316L SST	316L SST	316 SST	★
CB ⁽¹⁾	Alloy C-276	316L SST	CS	★
DB ⁽¹⁾	Alloy C-276, seam-welded	316L SST	316 SST	★
CC	Tantalum	316L SST	CS	★
DC	Tantalum, seam-welded	316L SST	316 SST	★
Flushing connection ring (lower housing)				
0	None			★
A ⁽²⁾	316 SST			★
B ⁽²⁾	Alloy C-276			★
Flushing connection quantity and size				
0	None			★
1	One ¼–18 NPT flushing connection			★
3	Two ¼–18 NPT flushing connections			★
7	One ½–14 NPT flushing connection			★
9	Two ½–14 NPT flushing connections			★
Options (include with selected model number)				
Cold temperature remote seal applications				
RB	Extra fill fluid for cold temperature applications			
Remote seal diaphragm thickness⁽³⁾				
SC	0.006-in. (150 µm) available with 316L SST and Alloy C-276			
Flushing connection ring plugs				
SF	Alloy C-276 plug(s) for flushing connection(s)			★
SG	SST plug(s) for flushing connection(s)			★
SH	SST drain/vent(s) for flushing connection(s)			★
Lower housing alignment clamp				
SA	Lower housing alignment clamp			★

Table 10: Flush Flanged (FF) Seal Ordering Information (continued)

Intermediate gasket material		
S0	No gasket for flushing ring connection (lower housing)	★
SY	Thermo-tork® TN-9000	★
SJ	PTFE gasket	★
SK	Barium Sulfate-filled PTFE gasket	
SN	GRAFOIL® gasket	
Remote seal diaphragm coating		
SZ ⁽³⁾	0.0002-in. (5 µm) gold-plated diaphragm	
SV	PTFE coated diaphragm for non-stick purposes	
Complete the 3051SAL model number by specifying options as needed:		
Table 8	ERS Transmitter options	
Table 9	Scalable level transmitter options	

(1) Not available with option code SC.

(2) Supplied with Thermo-tork® TN-9000 gasket if no other flushing connection ring gasket option is selected.

(3) Not available with Tantalum diaphragms (Material of Construction codes CC and DC).



Extended Flanged (EF) Seal

- Good for use in viscous applications with plugging issues
- Seal diaphragm installed flush with inner tank wall to prevent process plugging
- Easy installation on 3-in. (DN 80) and 4-in. (DN 100) flanged connections

Specification and selection of product materials, options, or components must be made by the purchaser of the equipment. See [Material selection](#) for more information .

The starred offerings (★) represent the most common options and should be selected for best delivery. The non-starred offerings are subject to additional delivery lead time.

Table 11: Extended Flanged (EF) Seal Ordering Information

Model	Process connection				
EF	Extended flanged seal				
Process connection size					
	ANSI/ASME B16.5	EN 1092-1/GOST 33259-15	JIS B2238	Extension diameters	
7	3-in. schedule 80	DN 80	80A	2.58-in. (66 mm)	★
9	4-in. schedule 80	DN 100	100A	3.50-in. (89 mm)	★
Flange/pressure rating					
1	ANSI/ASME B16.5 Class 150				★
2	ANSI/ASME B16.5 Class 300				★
4	ANSI/ASME B16.5 Class 600				★
G	PN 40 per EN 1092-1				★

Table 11: Extended Flanged (EF) Seal Ordering Information (continued)

5	ANSI/ASME B16.5 Class 900			
6	ANSI/ASME B16.5 Class 1500			
7	ANSI/ASME B16.5 Class 2500			
H	PN 63 per EN 1092-1			
J	PN 100 per EN 1092-1			
A	10K per JIS B2238			
B	20K per JIS B2238			
D	40K per JIS B2238			
E	PN 10/16 per EN 1092-1, available with DN 100 only			
Materials of construction				
	Isolating diaphragm	Extension/gasket surface	Mounting flange	
CA	316L SST	316L SST	CS	★
DA	316L SST	316L SST	316 SST	★
CB	Alloy C-276	Alloy C-276	CS	★
DB	Alloy C-276	Alloy C-276	316 SST	★
Seal extension length				
20	2-in. (50 mm)			★
40	4-in. (100 mm)			★
60	6-in. (150 mm)			★
Options (include with selected model number)				
Cold temperature remote seal applications				
RB	Extra fill fluid for cold temperature applications			★
Remote seal diaphragm thickness				
SC	0.006-in. (150 μm) diaphragm thickness			
Remote seal diaphragm coating				
SZ	0.0002-in. (5 μm) gold-plated diaphragm			
SV	PTFE coated diaphragm for non-stick purposes			
Complete the 3051SAL model number by specifying options as needed:				
Table 8	ERS Transmitter options			
Table 9	Scalable level transmitter options			



Remote Flanged (RF) Seal

- Designed to improve performance on smaller process connections
- Easy installation on flanged connections ranging from ½- to 1½-in. (DN 25– DN 40)
- Lower housing/flushing ring required

Specification and selection of product materials, options, or components must be made by the purchaser of the equipment. See [Material selection](#) for more information .

The starred offerings (★) represent the most common options and should be selected for best delivery. The non-starred offerings are subject to additional delivery lead time.

Table 12: Remote Flanged (RF) Seal Ordering Information

Model	Process connection			
RF	Remote flanged seal			
Process connection size				
	ANSI/ASME B16.5	EN 1092-1/GOST 33259-15	JIS B2238	
2	1-in.	N/A	25A	★
4	1½-in.	N/A	40A	★
D	N/A	DN 25	N/A	★
F	N/A	DN 40	N/A	★
1	½-in.	N/A	N/A	
A	¾-in.	N/A	N/A	
Flange/pressure rating				
1	ANSI/ASME B16.5 Class 150			★
2	ANSI/ASME B16.5 Class 300			★
4	ANSI/ASME B16.5 Class 600			★
G	PN 40 per EN 1092-1			★
5	ANSI/ASME B16.5 Class 900			
6	ANSI/ASME B16.5 Class 1500			
7	ANSI/ASME B16.5 Class 2500			
A	10K per JIS B2238			
B	20K per JIS B2238			
D	40K per JIS B2238			
Materials of construction				
	Isolating diaphragm	Upper housing	Flange	
CA	316L SST	316L SST	CS	★
DA	316L SST	316L SST	316 SST	★
CB	Alloy C-276	316L SST	CS	★
DB	Alloy C-276	316L SST	316 SST	★
CC	Tantalum	316L SST	CS	★
DC	Tantalum	316L SST	316 SST	★
Flushing connection ring material (lower housing)⁽¹⁾				
A	316L SST			★
B	Alloy C-276			★
Flushing connection quantity and size				
5	None			★
1	One ¼–18 NPT flushing connection			★

Table 12: Remote Flanged (RF) Seal Ordering Information (continued)

3	Two ¼–18 NPT flushing connections	★
7	One ½–14 NPT flushing connection	
9	Two ½–14 NPT flushing connections	
Options (include with selected model number)		
Cold temperature remote seal application		
RB	Extra fill fluid for cold temperature applications	★
Remote seal diaphragm thickness		
SC ⁽²⁾	0.006-in. (150 µm) diaphragm thickness	
Large diaphragm size		
S9	4.1-in. (104 mm) diaphragm diameter	
Flushing connection ring plugs		
SF	Alloy C-276 plug(s) for flushing connection(s)	★
SG	316 SST plug(s) for flushing connection(s)	★
SH	316 SST drain/vent(s) for flushing connection(s)	★
Flushing ring connection gaskets		
SY	C-4401 gasket	★
SJ	PTFE gasket	★
SR	Ethylene Propylene gasket	
SN	GRAFOIL gasket	
S6	TopChem 2000	
SK	Barium Sulfate-filled PTFE gasket	
Remote seal bolt material		
S3	304 SST bolts	★
S4	316 SST bolts	
Remote seal diaphragm coating		
SZ ⁽²⁾	0.0002-in. (5 µm) gold-plated diaphragm	
SV	PTFE coated diaphragm for non-stick purposes	
Complete the 3051SAL model number by specifying options as needed:		
Table 8	ERS Transmitter options	
Table 9	Scalable level transmitter options	

(1) Supplied with C-4401 Aramid fiber gasket if no other remote seal gasket material is selected.

(2) Not available with Tantalum diaphragms (Material of Construction codes CC and DC).



PF Pancake Seal

- Remote mount connection with capillary on the side of the seal

- Support tube used to facilitate installation
- Can be ordered with or without flange

The starred offerings (★) represent the most common options and should be selected for best delivery. The non-starred offerings are subject to additional delivery lead time.

Table 13: PF Pancake Seal Ordering Information

Model	Process connection			
PF	Pancake seal			★
Process connection size				
	ANSI	EN 1092-1/GOST 33259-15		
G	2-in.	DN 50		★
7	3-in.	N/A		★
J	N/A	DN 80		★
Flange/pressure rating				
	ANSI	EN 1092-1/GOST 33259-15		
0	No flanged supplied, seal maximum working pressure (MWP) based on customer supplied flange		N/A	★
9	N/A		No flanged supplied, seal MWP based on customer supplied flange	★
1	Class 150		N/A	★
2	Class 300		N/A	★
4	Class 600		N/A	★
G	N/A		PN40	★
5	Class 900		N/A	
6	Class 1500		N/A	
7	Class 2500		N/A	
H	N/A		PN63	
J	N/A		PN100	
Diaphragm and wetted, upper housing, flange material				
	Diaphragm and wetted	Upper housing	Flange	
LA ⁽¹⁾	316L SST	316L SST	None	★
CA ⁽¹⁾	316L SST	316L SST	CS	★
DA ⁽¹⁾	316L SST	316L SST	316 SST	★
LB	Alloy C-276, seam welded	316L SST	None	★
CB	Alloy C-276, seam welded	316L SST	CS	★
DB	Alloy C-276, seam welded	316L SST	316 SST	★
LC	Tantalum, seam welded	316L SST	None	★
CC	Tantalum, seam welded	316L SST	CS	★
DC	Tantalum, seam welded	316L SST	316 SST	★
Flushing connection ring (lower housing)				
0	None			★
A ⁽²⁾	316 SST			★

Table 13: PF Pancake Seal Ordering Information (continued)

B ⁽²⁾	Alloy C-276	★
Flushing connection quantity and size		
0	None	★
1	One ¼–18 NPT flushing connection	★
3	Two ¼–18 NPT flushing connections	★
7	One ½–14 NPT flushing connection	★
9	Two ½–14 NPT flushing connections	★
Options (include with selected model number)		
Lower housing alignment clamp		
SA	Lower housing alignment clamp	★
Flushing connection ring gaskets⁽²⁾		
S0	No gasket for lower housing	★
SY	Thermo-tork TN-9000	★
SJ	PTFE gasket	★
SK	Barium Sulfate-filled PTFE gasket	
SN	GRAFOIL gasket	
Flushing connection ring plugs		
SF	Alloy C-276 plug(s) for flushing connection(s)	★
SG	SST plug(s) for flushing connection(s)	★
SH	SST drain/vent(s) for flushing connection(s)	★
Remote seal diaphragm thickness⁽³⁾		
SC	0.006-in. (150 µm) diaphragm thickness	
Cold temperature remote seal applications		
RB	Extra fill fluid for cold temperature applications	
Remote seal diaphragm coating		
SZ ⁽³⁾	0.0002-in. (5 µm) gold-plated diaphragm	
SV	PTFE coated diaphragm for non-stick purposes	
Complete the 3051SAL model number by specifying options as needed:		
Table 9	Scalable level transmitter options	

(1) For use with customer supplied spiral metallic gaskets.

(2) Supplied with Thermo-tork TN-9000 gasket if no other flushing connection ring gasket option is selected.

(3) Not available with Tantalum diaphragms (Material of Construction codes CC and DC).



FC Flush Flanged Seal - Ring Type Joint (RTJ) gasket surface

- RTJ gaskets are metallic sealing rings, often used in high pressure/high temperature applications
- Gasket surface on seal contains groove for RTJ gasket (user supplied)

The starred offerings (★) represent the most common options and should be selected for best delivery. The non-starred offerings are subject to additional delivery lead time.

Table 14: FC Flush Flanged Seal - Ring Type Joint (RTJ) Gasket Surface Ordering Information

Model	Process connection		
FC	Flush flanged seal - Ring Type Joint (RTJ) gasket surface		
Process connection size			
G	2-in.		
7	3-in.		
9	4-in.		
Flange/pressure rating			
1	Class 150		
2	Class 300		
4	Class 600		
5	Class 900		
6	Class 1500		
7	Class 2500		
Diaphragm and wetted, upper housing, flange material			
	Diaphragm and wetted	Upper housing	Flange
DA	316L SST	316L SST	316 SST
KB	Alloy C-276	316L SST	316 SST
MB	Alloy C-276	316L SST	CS
CA	316L SST	316L SST	CS
Flushing connection ring material (lower housing)			
0	None		
A	316 SST		
B	Alloy C-276		
Flushing connection quantity and size			
0	None		
1	One ¼–18 NPT flushing connection		
3	Two ¼–18 NPT flushing connection		
7	One ½–14 NPT flushing connection		
9	Two ½–14 NPT flushing connection		
Options (include with selected model number)			
Flushing ring connection plugs			
SF	Alloy C-276 plug(s) for flushing connection(s)		
SG	316 SST plug(s) for flushing connection(s)		
SH	316 SST vent/drain for flushing connection(s)		
Remote seal diaphragm thickness			
SC	0.006-in. (150 µm) available with 316L SST, Alloy C-276, and duplex 2205 SST for abrasive applications		

Table 14: FC Flush Flanged Seal - Ring Type Joint (RTJ) Gasket Surface Ordering Information (continued)

Cold temperature remote seal application	
RB	Extra fill for cold temp application
Remote seal diaphragm coating ⁽¹⁾	
SZ	0.002-in. (5 μm) gold-plated diaphragm
SV	PTFE coated diaphragm for nonstick purposes only
Complete the 3051SAL model number by specifying options as needed:	
Table 8	ERS Transmitter options
Table 9	Scalable level transmitter options

(1) Only available on 316LSST and Alloy C-276.

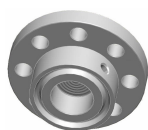

RC Remote Flanged Seal - Ring Type Joint (RTJ) gasket surface

- Remote mounted with capillary
- RTJ gaskets are metallic sealing rings, often used in high pressure/high temperature applications
- Gasket surface on seal contains groove for RTJ gasket (user supplied)

The starred offerings (★) represent the most common options and should be selected for best delivery. The non-starred offerings are subject to additional delivery lead time.

Table 15: RC Remote Flanged Seal - Ring Type Joint (RTJ) Gasket Surface Ordering Information

Model	Process connection		
RC	Remote flanged seal - Ring Type Joint (RTJ) gasket surface		
Process connection sizes			
1	½-in. (Class 150 to 1500 includes mounting ring bolts and mounting studs)		
A	¾-in. (Class 150 includes mounting ring bolts and mounting studs)		
2	1-in.		
4	1½-in.		
Flange/pressure rating			
1	Class 150		
2	Class 300		
4	Class 600		
5	Class 900		
6	Class 1500		
7	Class 2500		
Diaphragm and wetted, upper housing, flange material			
	Diaphragm and wetted	Upper housing	Flange
DA	316L SST	316L SST	316 SST
DB	Alloy C-276	316L SST	316 SST
DC	Tantalum	316L SST	316 SST

Table 15: RC Remote Flanged Seal - Ring Type Joint (RTJ) Gasket Surface Ordering Information (continued)

Flushing connection ring material (lower housing) ⁽¹⁾		
A	316L SST	
B	Alloy C-276	
Flushing ring connection and size		
0	None	
1	One ¼–18 NPT flushing connections	
3	Two ¼–18 NPT flushing connection	
7	One ½–14 NPT flushing connection	
9	Two ½–14 NPT flushing connection	
Options (include with selected model number)		
Flushing connection ring gaskets		
SY	C-4401 gasket	★
SJ	PTFE gasket	★
SR	Ethylene Propylene gasket	
SN	GRAFOIL gasket	
S6	TopChem 2000	
SK	Barium Sulfate-filled PTFE gasket	
Flushing connection ring plugs		
SF	Alloy C-276 plug(s) for flushing connection(s)	
SG	316 SST plug(s) for flushing connection(s)	
SH	316 SST vent/drain for flushing connection(s)	
Remote seal diaphragm thickness		
SC	0.006-in. (150 µm) available with 316L SST, Alloy C-276, and duplex 2205 SST for abrasive applications	
Remote seal bolt material		
S3 ⁽²⁾	304 SST bolts (only available for stud bolt design)	
S4	316 SST bolts (only available for stud bolt design)	★
Large diaphragm size		
S9	4.1 in. (104 mm) diaphragm diameter	
Cold temperature remote seal application		
RB	Extra fill for cold temp application	
Remote seal diaphragm coating ⁽³⁾		
SZ	0.002-in. (5 µm) gold-plated diaphragm	
SV	PTFE coated diaphragm for nonstick purposes only	
Complete the 3051SAL model number by specifying options as needed:		
Table 8	ERS Transmitter options	
Table 9	Scalable level transmitter options	

(1) Supplied with C-4401 aramid fiber gasket if no other remote seal gasket material is selected.

- (2) Standard stud bolts are carbon steel.
 (3) Only available on 316L SST and Alloy C-276.



Remote Threaded (RT) Seal

- For use with threaded process connections (¼-18 to 1-11.5 NPT)
- Rated for use in high-pressure applications (up to 2500 PSI)
- Optional flushing connections available

The starred offerings (★) represent the most common options and should be selected for best delivery. The non-starred offerings are subject to additional delivery lead time.

Table 16: RT Threaded Seal Ordering Information

Model	Process connection			
RT	Remote threaded seal			★
Process connection size				
3	½-14 NPT			★
4	¾-14 NPT			★
5	1-11.5 NPT			★
1	¼-18 NPT			
6	1¼ - 11.5 NPT			
Pressure rating				
0	2500 psi			★
8 ⁽¹⁾	1500 psi			★
Isolating diaphragm material		Upper housing material	Flange	
CA	316L SST	316L SST	CS	★
DA	316L SST	316L SST	316 SST	★
CB	Alloy C-276	316L SST	CS	★
DB	Alloy C-276	316L SST	316 SST	★
CC	Tantalum	316L SST	CS	★
DC	Tantalum	316L SST	316 SST	★
Flushing connection ring material (lower housing)⁽²⁾⁽³⁾				
A	316L SST			★
B	Alloy C-276			★
Flushing ring connection quantity and size				
1	One ¼-in. flushing connection			★
3	Two ¼-in. flushing connections			★
5	None			★
7	One ½-14 NPT flushing connection			★
9	Two ½-14 NPT flushing connection			★

Table 16: RT Threaded Seal Ordering Information (continued)

Options (include with selected model number)		
Cold temperature remote seal application		
RB	Extra fill fluid for cold temperature applications	★
Remote seal diaphragm thickness		
SC ⁽⁴⁾	0.006-in. (150 μm) diaphragm thickness	
Remote seal flushing plug, drain/vent		
SF	Alloy C-276 plug(s) for flushing connection(s)	★
SG	316 SST plug(s) for flushing connection(s)	★
SH	316 SST drain/vent(s) for flushing connection(s)	★
Remote seal gasket material		
SY	C-4401 gasket (for use with flushing connection ring)	★
SJ	PTFE gasket (for use with flushing connection ring)	★
SR	Ethylene Propylene gasket (for use with flushing connection ring)	★
SN	GRAFOIL gasket (for use with flushing connection ring)	★
S6	TopChem 2000 (for use with flushing connection ring)	
SK	Barium Sulfate-filled PTFE gasket (for use with flushing connection ring)	
Remote seal bolt		
S3	304 SST bolts	★
S4	316 SST bolts	
Large diaphragm size		
S9 ⁽⁵⁾	4.1-in. (104 mm) diaphragm diameter	
Remote seal diaphragm coating		
SZ ⁽⁴⁾	0.0002-in. (5 μm) gold-plated diaphragm	
SV	PTFE coated diaphragm for non-stick purposes	
Special threads in lower housing		
R9	Male lower housing threads	
Complete the 3051SAL model number by specifying options as needed:		
Table 8	ERS transmitter options	
Table 9	Scalable level transmitter options	

- (1) Only available with 4.1 in. (104 mm) diaphragm (large diaphragm side code S9).
- (2) Supplied with C4401 aramid fiber gasket if no other remote seal gasket material is selected.
- (3) Flushing connection ring/lower housing assembly bolts provided as standard are carbon steel.
- (4) Not available with Tantalum diaphragms (Material of Construction codes CC and DC).
- (5) Only available with Pressure Rating code 8.

SC Hygienic Tri Clamp Seal



- Good for use in hygienic applications
- Easy installation on Tri-Clover style Tri Clamp connections (1.5-in. to 3-in.)
- Conforms to 3-A[®] standard 74-03

The starred offerings (★) represent the most common options and should be selected for best delivery. The non-starred offerings are subject to additional delivery lead time.

Table 17: SC Hygienic Tri-Clover Style Tri Clamp Seal Ordering Information

Process connection		
SC ⁽¹⁾	Tri-Clover style Tri Clamp seal	★
Process connection size		
3 ⁽²⁾	1 ½-in.	★
5 ⁽³⁾	2-in.	★
7	3-in.	★
Maximum working pressure		
0	1000 PSI	★
Isolating diaphragm material		Upper housing material
LA00	316L SST	316L SST
LB00	Alloy C-276	316L SST
Options (include with selected model number)		
Remote seal diaphragm polishing		
RE	Electropolishing	
Remote seal diaphragm surface finish		
RD	10 µin. (0.25 µm) R _a diaphragm surface finish	
RG	15 µin. (0.375 µm) R _a diaphragm surface finish	
RH	20 µin. (0.5 µm) R _a diaphragm surface finish	
Surface finish certification ⁽⁴⁾		
Q16	Surface finish certification for hygienic remote seals	★
Complete the Rosemount 3051SAL model number by specifying options as needed:		
Table 8	ERS Transmitter options	
Table 9	Scalable level transmitter options	

(1) Clamp and gasket furnished by user. The maximum working pressure is dependent upon the clamp pressure rating.

(2) Min-span is 1000 inH₂O or 2490 mbar for 1 ½-in. Tri Clamp seal.

(3) Min-span is 150 inH₂O or 373 mbar for 2-in. Tri Clamp seal.

(4) Q16 is only available when the diaphragm seal has surface finish options (RD, RG, and RH).

SS Hygienic Tank Spud Seal



- Commonly used in hygienic level applications
- Seal diaphragm installed flush with inner tank wall

- Conforms to 3-A standard 74-03

The starred offerings (★) represent the most common options and should be selected for best delivery. The non-starred offerings are subject to additional delivery lead time.

Table 18: SS Hygienic Tank Spud Seal Ordering Information

Process connection			
SS ⁽¹⁾	Hygienic Tank Spud Seal		★
Process connection size			
A	4-in. Sch. 5 Tri Clamp		★
Maximum working pressure (clamp rating)			
0	600 psi (41,37 bar)		★
Upper housing			
A	316L SST		★
Diaphragm and wetted, extension material			
	Diaphragm and wetted	Extension	
AL ⁽²⁾	316L SST	316L SST	★
BB	Alloy C-276	316L SST	
Extension length			
2	2-in. (50 mm) extension		★
6	6-in. (150 mm) extension		★
Options (include with selected model number)			
Remote seal diaphragm thickness			
SC	0.006-in. (150 μm) diaphragm thickness		
Tank spud included with shipment			
S1	Tank spud included with shipment		★
Remote seal diaphragm polishing			
RE	Electropolishing		
Remote seal diaphragm surface finish			
RH	20 μin. (0.5 μm) R _a diaphragm surface finish		
RG ⁽³⁾	15 μin. (0.375 μm) R _a diaphragm surface finish		
Surface finish certification ⁽⁴⁾			
Q16	Surface finishing certification for hygienic remote seals		★
Complete the 3051SAL model number by specifying options as needed:			
Table 8	ERS Transmitter options		
Table 9	Scalable level transmitter options		

(1) Clamp and Ethylene Propylene O-ring (conforms to 3-A standard 74 and USP Class VI) supplied.

(2) Diaphragm brazed and TIG-welded to extension.

(3) Requires option code RE (Electropolishing).

(4) Q16 is only available when the diaphragm seal has surface finish options (RG and RH).

Specifications

Performance specifications

Conformance to specification ($\pm 3\sigma$ [Sigma])

Technology leadership, advanced manufacturing techniques, and statistical process control ensure pressure measurement specification conformance to $\pm 3\sigma$ or better.

Reference accuracy

Stated reference accuracy equations include terminal based linearity, hysteresis, and repeatability. For FOUNDATION Fieldbus and wireless devices, use calibrated range in place of span.

For Rosemount 3051S assembled to Rosemount 1199 Remote Seals, use 3051SAL specifications.

Table 19: Transmitter with Coplanar Sensor Module (Single Variable)

Differential pressure (3051S_CD, 3051SMV__ 3 or 4)			
Gage pressure (3051S_CG, 3051SAM__G⁽¹⁾)			
	Ultra	Classic	Ultra for flow ⁽²⁾
Ranges 2–4	$\pm 0.025\%$ of span; For spans less than 10:1, $\pm(0.005 + 0.0035[\text{URL}/\text{Span}])\%$ of span	$\pm 0.035\%$ of span; For spans less than 10:1, $\pm(0.015 + 0.005[\text{URL}/\text{Span}])\%$ of span	$\pm 0.04\%$ of reading up to 8:1 DP turndown from URL; $\pm(0.04 + 0.0023[\text{URL}/\text{Reading}])\%$ of reading to 200:1 DP turndown from URL
Range 5	$\pm 0.05\%$ of span; For spans less than 10:1, $\pm(0.005 + 0.0045[\text{URL}/\text{Span}])\%$ of span	$\pm 0.065\%$ of span; For spans less than 10:1, $\pm(0.015 + 0.005[\text{URL}/\text{Span}])\%$ of span	N/A
Range 1	$\pm 0.09\%$ of span; For spans less than 15:1, $\pm(0.015 + 0.005[\text{URL}/\text{Span}])\%$ of span	$\pm 0.10\%$ of span; For spans less than 15:1, $\pm(0.025 + 0.005[\text{URL}/\text{Span}])\%$ of span	N/A
Range 0	$\pm 0.09\%$ of span; For spans less than 2:1, $\pm 0.045\%$ of URL	$\pm 0.10\%$ of span; For spans less than 2:1, $\pm 0.05\%$ of URL	N/A
Absolute pressure (3051S_CA, 3051SAM__A⁽¹⁾)			
	Ultra	Classic	
Ranges 1–4	$\pm 0.025\%$ of span; For spans less than 10:1, $\pm(0.004[\text{URL}/\text{Span}])\%$ of span	$\pm 0.035\%$ of span; For spans less than 10:1, $\pm(0.0065[\text{URL}/\text{Span}])\%$ of span	
Range 0	$\pm 0.075\%$ of span; For spans less than 5:1, $\pm(0.025 + 0.01[\text{URL}/\text{Span}])\%$ of span	$\pm 0.075\%$ of span; For spans less than 5:1, $\pm(0.025 + 0.01[\text{URL}/\text{Span}])\%$ of span	

(1) Specifications are for each gage/absolute pressure sensor of the ERS system and are not reflective of the DP calculation.

(2) Ultra for Flow is only available for 3051S_CD ranges 2-3. For calibrated spans from 1:1 to 2:1 of URL, add $\pm 0.005\%$ of span analog output error.

For Rosemount 3051S assembled to Rosemount 1199 Remote Seals, use 3051SAL specifications.

Table 20: Transmitter with In-Line Sensor Module

Absolute pressure (3051S_TA, 3051SAM_E ⁽¹⁾)		
Gage pressure (3051S_TG, 3051SAM_T ⁽¹⁾)		
	Ultra	Classic
Ranges 1–4	±0.025% of span For spans less than 10:1, ±(0.004[URL/ Span])% of span	±0.035% of span For spans less than 10:1, ±(0.0065[URL/ Span])% of span
Range 5	±0.04% of span For spans less than 10:1 ±0.004% of URL	±0.065% of span For spans less than 10:1 ±0.0065% of URL

(1) Specifications are for each gage/absolute pressure sensor of the ERS system and are not reflective of the DP calculation.

For Rosemount 3051S assembled to Rosemount 1199 Remote Seals, use 3051SAL specifications.

Table 21: Transmitter with Multivariable Sensor Module

Differential pressure and Static pressure (3051SMV_1 or 2)		
	Classic MV	Ultra for flow ⁽¹⁾
DP Ranges 2–3	±0.04% of span For spans less than 10:1, ±(0.01 + 0.004[URL/ Span])% of span	±0.04% of reading up to 8:1 DP turndown from URL ±(0.04 + 0.0023[URL/ Reading])% of reading to 200:1 DP turndown from URL
DP Range 4	±0.055% of span For spans less than 10:1, ±(0.015 + 0.005[URL/ Span])% of span	±0.05% of reading up to 3:1 DP turndown from URL ±(0.05 + 0.0145[URL/ RDG])% of reading to 100:1 DP turndown from URL
DP Range 5	±0.065% of span For spans less than 10:1, ±(0.015 + 0.005[URL/ Span])% of span	N/A
DP Range 1	±0.10% of span For spans less than 15:1, ±(0.025 + 0.005[URL/ Span])% of span	N/A
AP and GP Ranges 3–4 ⁽²⁾	±0.055% of span For spans less than 10:1, ±(0.0065[URL/ Span])% of span	±0.025% of span For spans less than 10:1, ±(0.004[URL/ Span])% of span

(1) Ultra for Flow is only available for Rosemount 3051SMV DP ranges 2-4. For calibrated DP spans from 1:1 to 2:1 of URL, add ±0.005% of span analog output error with transmitter output code A.

(2) For DP range 1, 4 or 5, Classic MV and Ultra for Flow static pressure accuracy is ±0.055% of span on SP Range 4 only. For spans less than 5:1, ±(0.013[URL/ Span])% of span.

Table 22: Liquid Level Transmitter

Rosemount 3051SAL		
	Ultra	Classic
Ranges 2–5	±0.055% of span For spans less than 10:1, ±(0.015 + 0.005[URL/ Span])% of span	±0.065% of span For spans less than 10:1, ±(0.015 + 0.005[URL/ Span])% of span

Reference Accuracy specifications for ERS system assume that the configuration contains two transmitters with identical sensor ranges, each transmitter sensor is calibrated 0 – URL, and the DP Span = 10% of transmitter URL.

Table 23: DP Reference Accuracy of Rosemount 3051S ERS System

2 Coplanar gage transmitters (3051SAM__G)		
	Ultra	Classic
Ranges 2–4	±0.035% of DP span	±0.049% of DP span
Range 5	±0.071% of DP span	±0.092% of DP span
2 Coplanar absolute transmitters (3051SAM__A)		
	Ultra	Classic
Ranges 1–4	±0.035% of DP span	±0.049% of DP span
2 In-line gage transmitters (3051SAM__T)		
	Ultra	Classic
Ranges 1–4	±0.035% of DP span	±0.049% of DP span
2 Liquid level transmitters (3051SAL)		
	Ultra	Classic
Ranges 1–5	±0.092% of DP span	±0.092% of DP span

Process temperature RTD interface

Specifications for process temperature are for the transmitter portion only. The transmitter is compatible with any Pt 100 (100 ohm platinum) RTD. Examples of compatible RTDs include Rosemount series 68 and 78 RTD Temperature Sensors.

Process temperature (3051SMV__1 or 3)
±0.67 °F (0.37 °C)

DP total accuracy for Enhanced ERS System performance

Includes full ambient and temperature range from –40 to 85 °C (–40 to 185 °F) requires two transmitters with identical sensor ranges. Specification are only applicable for spans down to 10:1.

Sensor type	3051SAM__G2, 3051SAL__G2 250 inH₂O (622,1 mbar)	3051SAM__G3, 3051SAL__G3 1000 inH₂O (2488,4 mbar)	3051SAM__T1, 3051SAL__T1 30 psi (2,1 bar)	3051SAM__T2, 3051SAL__T2 150 psi (10,34 bar)	3051SAM__G4, 3051SAL__G4 300 psi (20,7 bar)	3051SAM__T3, 3051SAL__T3 800 psi (55,2 bar)
Rosemount 3051SAM ⁽¹⁾	0.2 inH ₂ O (0,5 mbar)	0.6 inH ₂ O (1,4 mbar)	0.9 inH ₂ O (2,2 mbar)	1.5 inH ₂ O (4,0 mbar)	6.2 inH ₂ O (15 mbar)	7.8 inH ₂ O (19 mbar)
Rosemount 3051SAL with direct mount seal types and sizes below ⁽²⁾ : <ul style="list-style-type: none"> ■ FF, FC, PF ≥ 2-in./DN50 ■ EF ≥ 3-in./DN80 ■ All RT, RF, RC, SS ■ SC ≥ 2.5-in. 	2.2 inH ₂ O (5,5 mbar)	2.3 inH ₂ O (5,8 mbar)	3.0 inH ₂ O (7,5 mbar)	3.2 inH ₂ O (8,0 mbar)	6.5 inH ₂ O (16 mbar)	8.3 inH ₂ O (21 mbar)

Sensor type	3051SAM_G2, 3051SAL_G2 250 inH ₂ O (622,1 mbar)	3051SAM_G3, 3051SAL_G3 1000 inH ₂ O (2488,4 mbar)	3051SAM_T1, 3051SAL_T1 30 psi (2,1 bar)	3051SAM_T2, 3051SAL_T2 150 psi (10,34 bar)	3051SAM_G4, 3051SAL_G4 300 psi (20,7 bar)	3051SAM_T3, 3051SAL_T3 800 psi (55,2 bar)
Rosemount 3051SAL with other seal types and sizes	Consult Instrument Toolkit™ for performance.					

- (1) For Rosemount 3051SAM assembled to a Rosemount 1199 Diaphragm Seal, use Rosemount 3051SAL specification for identical seal types and sizes.
- (2) For Rosemount 3051SAL with direct mount seals, specification applies to process temperatures from -45 to 205 °C and excludes diaphragm option code SC, 6-mil diaphragm thickness. Seal types outside these parameters will require a Toolkit calculation for performance.

Transmitter total performance

Total performance is based on combined errors of reference accuracy, ambient temperature effect, and line pressure effect at normal operating conditions (70% of span typical reading, 740 psi [51 bar] line pressure).

Models	Ultra	Classic and classic MV	Ultra for flow ⁽¹⁾
3051S_CD	Ranges 2–3	For ±50 °F (28 °C) temperature changes, 0–100% relative humidity, from 1:1 to 5:1 rangedown	For ±50 °F (28 °C) temperature changes, 0–100% relative humidity, over 8:1 DP turn-down from URL
3051S_CG	Ranges 2–5		
3051S_CA	Ranges 2–4		
3051S_T	Ranges 2–4		
3051SMV ⁽²⁾	DP Ranges 2–3		
3051SAM_G ⁽³⁾	Ranges 2–5		
3051SAM_A ⁽³⁾	Ranges 2–4		
3051SAM_T ⁽³⁾	Ranges 2–4		
3051SAM_E ⁽³⁾	Ranges 2–4		
3051SAL	Use Instrument Toolkit or the QZ Option to quantify the total performance of a remote seal assembly under operating conditions.		

- (1) Ultra for Flow is only available for 3051S_CD Ranges 2–3 and 3051SMV DP Ranges 2–4.
- (2) For Rosemount 3051SMV, Transmitter Total Performance specification applies to differential pressure measurement only.
- (3) Specifications are for each gage/absolute pressure sensor of the ERS system and are not reflective of the DP calculation.

Multivariable flow performance

Note

Flow performance specifications assume device is configured for full compensation of static pressure, process temperature, density, viscosity, gas expansion, discharge coefficient, and thermal correction variances over the specified process operating range using multivariable type M or flow meter measurement types 1 through 4.

Mass, Energy, Actual Volumetric, and Totalized Flow Reference Accuracy ⁽¹⁾		
Models	Ultra for flow	Classic MV ⁽²⁾
3051SMV ⁽³⁾		
DP Ranges 2–3	±0.65% of Flow Rate over a 14:1 flow range (200:1 DP range)	±0.70% of Flow Rate over 8:1 flow range (64:1 DP range)
DP Range 1	N/A	±0.90% of Flow Rate over 8:1 flow range (64:1 DP range)

Mass, Energy, Actual Volumetric, and Totalized Flow Reference Accuracy ⁽¹⁾		
Models	Ultra for flow	Classic MV ⁽²⁾
Annubar flow meter (3051SFA)		
Ranges 2–3	±0.80% of flow rate at 14:1 flow turndown	±1.15% of flow rate at 8:1 flow turndown
Compact Annubar flow meter (3051SFC_A)		
Ranges 2–3		
Standard	±1.55% of flow rate at 14:1 flow turndown	±1.60% of flow rate at 8:1 flow turndown
Calibrated	±0.80% of flow rate at 14:1 flow turndown	±1.00% of flow rate at 8:1 flow turndown
Compact Conditioning Orifice flow meter (3051SFC_C)		
Ranges 2–3		
$\beta = 0.4$	±0.75% of flow rate at 14:1 flow turndown	±1.10% of flow rate at 8:1 flow turndown
$\beta = 0.50, 0.65$	±1.15% of flow rate at 14:1 flow turndown	±1.45% of flow rate at 8:1 flow turndown
Compact Orifice flow meter(3051SFC_P) ⁽⁴⁾		
Ranges 2-3		
$\beta = 0.4$	±1.30% of flow rate at 14:1 flow turndown	±1.45% of flow rate at 8:1 flow turndown
$\beta = 0.50, 0.65$	±1.30% of flow rate at 14:1 flow turndown	±1.45% of flow rate at 8:1 flow turndown
Integral Orifice flow meter (3051SFP)		
Ranges 2–3		
Bore < 0.160	±2.55% of flow rate at 14:1 flow turndown	±2.65% of flow rate at 8:1 flow turndown
$0.160 \leq \text{Bore} < 0.500$	±1.55% of flow rate at 14:1 flow turndown	±1.70% of flow rate at 8:1 flow turndown
$0.500 \leq \text{Bore} \leq 1.000$	±1.05% of flow rate at 14:1 flow turndown	±1.25% of flow rate at 8:1 flow turndown
$1.000 < \text{Bore}$	±1.55% of flow rate at 14:1 flow turndown	±1.70% of flow rate at 8:1 flow turndown

(1) Energy, actual volumetric, and totalized flow not available with transmitter output code F.

(2) Differential pressure calibrated at up to 1/10th full scale for optimum flow accuracy/rangeability.

(3) Uncalibrated differential producer (0.2 < β < 0.6 Orifice) installed per ASME MFC 3M or ISO 5167-1. Uncertainties for discharge coefficient, producer bore, tube diameter, and gas expansion factor as defined in ASME MFC 3M or ISO 5167-1. Reference accuracy does not include RTD sensor accuracy.

(4) For line sizes less than 2-in. (50mm) or greater than 8-in. (200 mm), see the Rosemount DP flow meters and Primary Elements [Product Data Sheet](#).

Uncompensated flow performance

Flow performance specifications assume the device only uses DP readings without pressure and temperature compensation.

Models	Ultra	Classic	Ultra for flow
Annubar flow meter (3051SFA)			
Ranges 2–3	±0.95% of flow rate at 8:1 flow turndown	±1.25% of flow rate at 8:1 flow turndown	±0.80% of flow rate at 14:1 flow turndown
Compact conditioning orifice flow meter (3051SFC_C)			
Ranges 2–3			
$\beta = 0.4$	±0.90% of flow rate at 8:1 flow turndown	±1.10% of flow rate at 8:1 flow turndown	±0.75% of flow rate at 14:1 flow turndown
$\beta = 0.50, 0.65$	±1.25% of flow rate at 8:1 flow turndown	±1.40% of flow rate at 8:1 flow turndown	±1.15% of flow rate at 14:1 flow turndown

Compact annubar flow meter (3051SFC_A)			
Ranges 2–3			
Uncalibrated	±1.65% of flow rate at 8:1 flow turndown	±1.70% of flow rate at 8:1 flow turndown	±1.55% of flow rate at 14:1 flow turndown
Calibrated	±0.95% of flow rate at 8:1 flow turndown	±1.25% of flow rate at 8:1 flow turndown	±0.80% of flow rate at 14:1 flow turndown
Models	Ultra	Classic	Ultra for flow
Compact orifice flow meter(3051SFC_P)⁽¹⁾			
Ranges 2–3			
β = 0.4	±1.35% of flow rate at 8:1 flow turndown	±1.80% of flow rate at 8:1 flow turndown	±1.30% of flow rate at 14:1 flow turndown
β = 0.50, 0.65	±1.35% of flow rate at 8:1 flow turndown	±1.80% of flow rate at 8:1 flow turndown	±1.30% of flow rate at 14:1 flow turndown
Integral orifice flow meter (3051SFP)			
Ranges 2–3			
Bore < 0.160	±2.65% of flow rate at 8:1 flow turndown	±2.70% of flow rate at 8:1 flow turndown	±2.60% of flow rate at 14:1 flow turndown
0.160 ≤ Bore < 0.500	±1.70% of flow rate at 8:1 flow turndown	±1.80% of flow rate at 8:1 flow turndown	±1.60% of flow rate at 14:1 flow turndown
0.500 ≤ Bore ≤ 1.000	±1.25% of flow rate at 8:1 flow turndown	±1.35% of flow rate at 8:1 flow turndown	±1.15% of flow rate at 14:1 flow turndown
1.000 < Bore	±1.70% of flow rate at 8:1 flow turndown	±1.80% of flow rate at 8:1 flow turndown	±1.60% of flow rate at 14:1 flow turndown

(1) For line sizes less than 2-in. (50 mm) or greater than 8-in. (200 mm), see the Rosemount DP flow meters and Primary Elements Product Data Sheet.

Long term stability

Table 24: Pressure

Models		Ultra, Enhanced, and Ultra for flow⁽¹⁾	Classic and Classic MV
3051S_CD	Ranges 2–5	±0.15% of URL for 15 years; for ±50 °F (28 °C) temperature changes, up to 1000 psi (68,95 bar) line pressure	±0.20% of URL for 15 years; for ±50 °F (28 °C) temperature changes, up to 1000 psi (68,95 bar) line pressure
3051S_CG	Ranges 2–5		
3051S_CA	Ranges 1–4		
3051S_T	Ranges 1–5		
3051SAM__G ⁽²⁾	Ranges 2–5		
3051SAM__A ⁽²⁾	Ranges 1–4		
3051SAM__T ⁽²⁾	Ranges 1–5		
3051SAM__E ⁽²⁾	Ranges 1–5		
3051SMV__3,4	Ranges 2–5		
3051SF__D,3,4	Ranges 2–5		
3051SMV__1,2	DP Ranges 2–5	±0.15% of URL for 15 years;	±0.20% of URL for 15 years;
3051SF_1,2	AP and GP Ranges 3–4	for ±50 °F (28 °C) temperature changes, up to 1000 psi (68,95 bar) line pressure	for ±50 °F (28 °C) temperature changes, up to 1000 psi (68,95 bar) line pressure

- (1) Ultra is only available for 3051S, 3051SMV__3 and 4, 3051SF_3, 4, 7, and D. Ultra for Flow is only available on 3051S_CD ranges 2–3, 3051SMV DP ranges 2–4, and 3051SF DP ranges 2–3.
- (2) Specifications are for each gage/absolute pressure sensor of the ERS system and are not reflective of the DP calculation.

Specifications for process temperature are for the transmitter portion only. The transmitter is compatible with any Pt 100 (100 ohm platinum) RTD. Examples of compatible RTDs include the Rosemount Series 68 and 78 RTD Temperature Sensors.

Table 25: Process Temperature

Models		
3051SMV 3051SF	RTD Interface	The greater of ± 0.185 °F (0.103 °C) or 0.1% of reading per 5 years (excludes RTD sensor stability).

Warranty

Note

Warranty details can be found in Emerson Terms and Conditions of Sale, Document 63445, Rev G (10/06).

Models	Ultra, Enhanced, and Ultra for flow ⁽¹⁾	Classic and Classic MV ⁽²⁾	Optional extended warranty ⁽³⁾
All Rosemount 3051S Products	15-year limited warranty	1-year limited warranty	WR3: 3-year limited warranty WR5: 5-year limited warranty

- (1) Rosemount Ultra and Ultra for Flow transmitters have a limited warranty of 15 years from date of shipment. All other provisions of Emerson standard limited warranty remain the same.
- (2) Goods are warranted for 12 months from the date of initial installation or 18 months from the date of shipment by seller, whichever period expires first.
- (3) Rosemount extended warranties have a limited warranty of three or five years from date of shipment.

Dynamic performance

For FOUNDATION Fieldbus (output code F), add 52 ms to stated values (not including segment macro-cycle). For option code DA2, add 45 ms (nominal) to stated values.

Consult Instrument Toolkit for transmitter configurations with remote seals including 3051SAL.

Table 26: Total Time Response at 75 °F (24 °C), Includes Dead Time

3051S_C 3051SF_D	3051S_T	3051SMV__1 or 2 3051SF_1, 2, 5, or 6	3051SMV__3 or 4 3051SF_3, 4, or 7	ERS System (3051SAM)
DP Ranges 2–5: 100 ms Range 1: 255 ms Range 0: 700 ms	100 ms	DP Range 1: 310 ms DP Range 2: 170 ms DP Range 3: 155 ms AP and GP: 240 ms	DP Ranges 2–5: 145 ms DP Range 1: 300 ms DP Range 0: 745 ms	360 ms

For option code DA2, dead time is 90 milliseconds (nominal).

Table 27: Dead Time

3051S_C 3051S_T 3051SF_D 3051SAL_C	3051SMV 3051SF_1-7	ERS System (includes 3051SAM, 3051SAL_P, and 3051SAL_S models)
45 ms (nominal)	DP: 100 ms AP and GP: 140 ms RTD Interface: 1 s	220 ms

Does not apply to Wireless (output code X). See [IEC 62591 \(WirelessHART® protocol\)](#) for wireless update rate.

Table 28: Sensor Update Rate

3051S_C or T			ERS System (includes 3051SAM, 3051SAL_P, and 3051SAL_S models)
3051SF_D	3051SMV		
3051SAL_C	3051SF_1-7		
22 updates per second	DP: 22 updates per sec. AP and GP: 11 updates per second RTD Interface: 1 update per second	Calculated variables ⁽¹⁾ : Mass/volumetric flow rate: 22 updates per second Energy flow rate: 22 updates per second Totalized flow: 1 update per second	11 updates per second

(1) Energy, Volumetric, and Totalized flow not available with transmitter output code F.

Ambient temperature effect

Table 29: Transmitter with Coplanar Sensor Module (Single Variable)

Differential Pressure: (3051S_CD, 3051SMV__3 or 4)			
Gage Pressure: (3051S_CG, 3051SAM__G ⁽¹⁾)			
	Ultra per 50 °F (28 °C)	Classic per 50 °F (28 °C)	Ultra for flow ⁽²⁾ -40 to 185 °F (-40 to 85 °C)
Ranges 2–5 ⁽³⁾	±(0.009% URL + 0.025% span) from 1:1 to 10:1; ±(0.018% URL + 0.08% span) from >10:1 to 200:1	±(0.0125% URL + 0.0625% span) from 1:1 to 5:1; ±(0.025% URL + 0.125% span) from >5:1 to 150:1	±0.13% of reading up to 8:1 DP turndown from URL; ±(0.0187% URL + 0.13% reading) > 8:1 and ≤ 100:1 DP turndown from URL
Range 0	±(0.25% URL + 0.05% span) from 1:1 to 30:1	±(0.25% URL + 0.05% span) from 1:1 to 30:1	N/A
Range 1	±(0.1% URL + 0.25% span) from 1:1 to 50:1	±(0.1% URL + 0.25% span) from 1:1 to 50:1	N/A
Absolute Pressure: (3051S_CA, 3051SAM__A ⁽¹⁾)			
	Ultra per 50 °F (28 °C)	Classic per 50 °F (28 °C)	
Ranges 2–4	±(0.0125% URL + 0.0625% span) from 1:1 to 5:1; ±(0.025% URL + 0.125% span) from >5:1 to 200:1	±(0.0125% URL + 0.0625% span) from 1:1 to 5:1; ±(0.025% URL + 0.125% span) from >5:1 to 150:1	
Range 0	±(0.1% URL + 0.25% span) from 1:1 to 30:1	±(0.1% URL + 0.25% span) from 1:1 to 30:1	
Range 1	±(0.0125% URL + 0.0625% span) from 1:1 to 5:1; ±(0.025% URL + 0.125% span) from >5:1 to 100:1	±(0.0125% URL + 0.0625% span) from 1:1 to 5:1; ±(0.025% URL + 0.125% span) from >5:1 to 100:1	

(1) Specifications are for each gage/absolute pressure sensor of the ERS system and are not reflective of the DP calculation.

(2) Ultra for Flow is only available for 3051S_CD Ranges 2–3 and 3051SMV DP Ranges 2–3.

(3) Use Classic specification for 3051SMV DP Range 5 Ultra and 3051S_CD Range 5 Ultra.

Table 30: Transmitter with In-line Sensor Module

Absolute Pressure: (3051S_TA, 3051SAM__E ⁽¹⁾)		
Gage Pressure: (3051S_TG, 3051SAM__T ⁽¹⁾)		
	Ultra per 50 °F (28 °C)	Classic per 50 °F (28 °C)
Ranges 2–4	±(0.009% URL + 0.025% span) from 1:1 to 10:1; ±(0.018% URL + 0.08% span) from >10:1 to 200:1	±(0.0125% URL + 0.0625% span) from 1:1 to 5:1; ±(0.025% URL + 0.125% span) from >5:1 to 150:1
Range 5	±(0.05% URL + 0.075% span) from 1:1 to 10:1	±(0.05% URL + 0.075% span) from 1:1 to 5:1
Range 1	±(0.0125% URL + 0.0625% span) from 1:1 to 5:1; ±(0.025% URL + 0.125% span) from >5:1 to 100:1	±(0.0125% URL + 0.0625% span) from 1:1 to 5:1; ±(0.025% URL + 0.125% span) from >5:1 to 100:1

(1) Specifications are for each gage/absolute pressure sensor of the ERS system and are not reflective of the DP calculation.

Table 31: Transmitter with Multivariable Sensor Module

Differential Pressure and Static Pressure (3051SMV__1 or 2)		
Models	Classic MV Per 50 °F (28 °C)	Ultra for flow -40 to 185 °F (-40 to 85 °C)
DP Ranges 2–3	±(0.0125% URL + 0.0625% span) from 1:1 to 5:1; ±(0.025% URL + 0.125% span) for >5:1 to 100:1	±0.13 reading up to 8:1 DP turndown from URL; ±(0.13 + 0.0187[URL/Reading])% reading to 100:1 DP turndown from URL
DP Range 4	±(0.025% URL + 0.125% span) from 1:1 to 30:1 ±(0.035% URL + 0.125% span) from 30:1 to 100:1	±0.130% of reading less than or equal to 3:1 ±(0.050 + 0.065 [URL/RDG])% of reading greater than 3:1
DP Range 5	±(0.025% URL + 0.125% span) from 1:1 to 30:1 ±(0.035% URL + 0.125% span) from 30:1 to 100:1	N/A
DP Range 1	±(0.1% URL + 0.25% span) from 1:1 to 50:1	Not available
AP and GP	±(0.0125% URL + 0.0625% span) from 1:1 to 10:1; ±(0.025% URL + 0.125% span) for >10:1 to 100:1	±(0.009% URL + 0.025% span) from 1:1 to 10:1; ±(0.018% URL + 0.08% span) for >10:1 ⁽¹⁾

(1) For DP range 4 or 5, Ultra for Flow ambient temperature effect on static pressure is ±(0.0125% URL + 0.0625% Span) from 1:1 to 10:1; ±(0.025% URL + 0.125% Span) for >10:1.

Table 32: Liquid Level Transmitter

Rosemount 3051SAL	
Ultra	Classic
See Instrument Toolkit.	See Instrument Toolkit.

Process temperature RTD interface

Specifications for process temperature are for the transmitter portion only. The transmitter is compatible with any Pt 100 (100 ohm platinum) RTD. Examples of compatible RTDs include Rosemount series 68 and 78 RTD Temperature Sensors.

Table 33: Process Temperature (3051SMV__1 or 3)

Classic MV Per 50 °F (28 °C)	Ultra for flow -40 to 185 °F (-40 to 85 °C)
±0.39 °F (0,216 °C) per 50 °F (28 °C)	±0.39 °F (0,216 °C) per 50 °F (28 °C)

Line pressure effect

Note

The line pressure effect specifications also apply to option code P9, where applicable.

3051S_CD 3051SMV (DP measurement only)	Ultra and Ultra for flow	Classic and classic MV
Zero error ⁽¹⁾		
Range 2–3	± 0.025% URL per 1000 psi (68,95 bar)	± 0.05% URL per 1000 psi (68,95 bar)
Range 0	± 0.125% URL per 100 psi (6,89 bar)	± 0.125% URL per 100 psi (6,89 bar)
Range 1	± 0.25% URL per 1000 psi (68,95 bar)	± 0.25% URL per 1000 psi (68,95 bar)
Span error ⁽²⁾		
Range 2–3	± 0.1% of reading per 1000 psi (68,95 bar)	± 0.1% of reading per 1000 psi (68,95 bar)
Range 0	± 0.15% of reading per 100 psi (6,89 bar)	± 0.15% of reading per 100 psi (6,89 bar)
Range 1	± 0.4% of reading per 1000 psi (68,95 bar)	± 0.4% of reading per 1000 psi (68,95 bar)

(1) Zero error can be removed by performing a zero trim at line pressure.

(2) Specifications for option code P0 are 2 times those shown above.

Mounting position effects

Models	Ultra, Ultra for flow, Classic and Classic MV	
3051S_CD or CG 3051SMV__3 or 4 3051SF_3, 4, 7, or D 3051SAM__G	Zero shifts up to ±1.25 inH ₂ O (3,11 mbar), which can be zeroed span: no effect	
3051S_CA 3051S_T 3051SAM__A, T, or E	Zero shifts to ±2.5 inH ₂ O (6,22 mbar), which can be zeroed span: no effect	
3051SMV__1 or 2 3051SF_1, 2, 5, or 6	DP Sensor	Zero shifts up to ±1.25 inH ₂ O (3,11 mbar), which can be zeroed span: no effect
	GP/AP Sensor	Zero shifts to ±2.5 inH ₂ O (6,22 mbar), which can be zeroed span: no effect
3051SAL	With liquid level diaphragm in vertical plane, zero shift of up to ±1 inH ₂ O (2,49 mbar). With diaphragm in vertical plane, zero shift of up to ±5 inH ₂ O (12,43 mbar) plus extension length on extended units. All zero shifts can be zeroed. Span: no effect	

Vibration effect

Less than ±0.1% of URL when tested per the requirements of IEC60770-1 field or pipeline with high vibration level (10–60 Hz 0.21 mm displacement peak amplitude/60–2000 Hz 3g).

For Housing Style codes 1J, 1K, 1L, 2J, and 2M: Less than $\pm 0.1\%$ of URL when tested per the requirements of IEC60770-1 field with general application or pipeline with low vibration level (10–60 Hz 0.15 mm displacement peak amplitude/60–500 Hz 2g).

Power supply effect

Less than $\pm 0.005\%$ of calibrated span per volt change in voltage at the transmitter terminals

Electromagnetic compatibility (EMC)

Meets all industrial environment requirements of EN61326 and NAMUR NE-21.

Note

NAMUR NE-21 is met on Rosemount 3051SMV output type A if no external temperature sensor is attached. NAMUR NE-21 does not apply to wireless output code X or ERS configurations.

Maximum deviation < 1% Span during EMC disturbance.

Note

During surge event device may exceed maximum EMC deviation limit or reset; however, device will self-recover and return to normal operation within specified start-up time. For devices with Junction Box housing or Remote Display (housing styles: 2A-2C, 2E-2G, 2J, 2M) testing performed with shielded cable. Rosemount 3051SMV Measurement Type 1, 3, 5, 6 and Rosemount 3051SF Measurement Type 1, 3, 5, 7 require shielded cable for the process temperature connection.

Transient protection (option T1)

Tested in accordance with IEEE C62.41.2-2002, Location Category B

- 6 kV crest (0.5 μ s – 100 kHz)
- 3 kA crest (8 \times 20 microseconds)
- 6 kV crest (1.2 \times 50 microseconds)

Functional specifications

Range and sensor limits

Table 34: Transmitter with Coplanar Sensor Module (Single Variable)

Range	DP Sensor ⁽¹⁾ (3051S_CD, 3051SMV__3, 4, or D 3051SF_3, 4, or 7, 3051SAL_CD)		GP Sensor (3051S_CG, 3051SAM__G, 3051SAL__G)		AP Sensor ⁽²⁾ (3051S_CA, 3051SAM__A, 3051SAL__A)	
	Lower (LRL) ⁽³⁾	Upper (URL)	Lower (LRL) ⁽⁴⁾	Upper (URL)	Lower (LRL)	Upper (URL)
0	-3.00 inH ₂ O (-7,46 mbar)	3.00 inH ₂ O (7,46 mbar)	N/A	N/A	0 psia (0 bar)	5.00 psia (0,34 bar)
1	-25.00 inH ₂ O (-62,16 mbar)	25.00 inH ₂ O (62,16 mbar)	-25.00 inH ₂ O (-62,16 mbar)	25.00 inH ₂ O (62,16 mbar)	0 psia (0 bar)	30.00 psia (2,07 bar)
2	-250.00 inH ₂ O (-621,60 mbar)	250.00 inH ₂ O (621,60 mbar)	-250.00 inH ₂ O (-621,60 mbar)	250.00 inH ₂ O (621,60 mbar)	0 psia (0 bar)	150.00 psia (10,34 bar)

Table 34: Transmitter with Coplanar Sensor Module (Single Variable) (continued)

Range	DP Sensor ⁽¹⁾ (3051S_CD, 3051SMV__3, 4, or D 3051SF_3, 4, or 7, 3051SAL_CD)		GP Sensor (3051S_CG, 3051SAM__G, 3051SAL__G)		AP Sensor ⁽²⁾ (3051S_CA, 3051SAM__A, 3051SAL__A)	
	Lower (LRL) ⁽³⁾	Upper (URL)	Lower (LRL) ⁽⁴⁾	Upper (URL)	Lower (LRL)	Upper (URL)
3	-1000.00 inH ₂ O (-2,49 bar)	1000.00 inH ₂ O (2,49 bar)	0.5 psia (34,47 mbar)	1000.00 inH ₂ O (2,49 bar)	0 psia (0 bar)	800.00 psia (55,16 bar)
4	-300.00 psi (-20,68 bar)	300.00 psi (20,68 bar)	0.5 psia (34,47 mbar)	300.00 psi (20,68 bar)	0 psia (0 bar)	4000.00 psia (275,79 bar)
5	-2000.00 psi (-137,90 bar)	2000.00 psi (137,90 bar)	0.5 psia (34,47 mbar)	2000.00 psi (137,90 bar)	N/A	N/A

- (1) Rosemount 3051SF flow meters only available with ranges 1, 2, and 3.
- (2) Range 0 is not available for 3051SAL__A.
- (3) The Lower Range Limit (LRL) is 0 inH₂O (0 mbar) for Ultra for Flow Performance Class and Rosemount 3051SF flow meters.
- (4) Assumes atmospheric pressure of 14.7 psia (1 bar).

Table 35: Transmitter with In-Line Sensor Module

Range	GP Sensor (3051S_TG, 3051SAM__T, 3051SAL__T)		AP Sensor (3051S_TA, 3051SAM__E, 3051SAL__E)	
	Lower (LRL) ⁽¹⁾	Upper (URL)	Lower (LRL)	Upper (URL)
1	-14.70 psig (-1,01 bar)	30.00 psig (2,07 bar)	0 psia (0 bar)	30.00 psia (2,07 bar)
2	-14.70 psig (-1,01 bar)	150.00 psig (10,34 bar)	0 psia (0 bar)	150.00 psia (10,34 bar)
3	-14.70 psig (-1,01 bar)	800.00 psig (55,16 bar)	0 psia (0 bar)	800.00 psia (55,16 bar)
4	-14.70 psig (-1,01 bar)	4000.00 psig (275,79 bar)	0 psia (0 bar)	4000.00 psia (275,79 bar)
5	-14.70 psig (-1,01 bar)	10000.00 psig (689,48 bar)	0 psia (0 bar)	10000.00 psia (689,48 bar)

- (1) Assumes atmospheric pressure of 14.7 psia (1 bar-a).

Table 36: Transmitter with Multivariable Sensor Module (3051SMV__1, 3051SMV__2, 3051SF_1, 3051SF_2, 3051SF_5, and 3051SF_6)

Range	DP Sensor	
	Lower (LRL) ⁽¹⁾	Upper (URL)
1	-25.00 inH ₂ O (-62,3 mbar)	25.00 inH ₂ O (62,3 mbar)
2	-250.00 inH ₂ O (62,0 bar)	250.00 inH ₂ O (0,62 bar)
3	-1000.00 inH ₂ O (-2,49 bar)	1000.00 inH ₂ O (2,49 bar)
4	-300.0 psi (20,7 bar)	300.0 psi (20,7 bar)
5	-2000.00 psi (137,9 bar)	2000.00 psi (137,9 bar)

- (1) Lower (LRL) is 0 inH₂O (0 mbar) for Ultra for Flow and Rosemount 3051SF_flow meters.

Table 37: Static Pressure Sensor (GP/AP)

Range	Lower (LRL)	Upper (URL) ⁽¹⁾
3	GP ⁽²⁾⁽³⁾ : -14.20 psig (-0,98 bar) AP: 0.50 psia (34,5 mbar)	GP: 800 psig (55,16 bar) AP: 800 psia (55,16 bar)

Table 37: Static Pressure Sensor (GP/AP) (continued)

4	GP ⁽²⁾⁽³⁾ : -14.20 psig (-0,98 bar) AP: 0.50 psia (34,5 mbar)	GP: 3626 psig (250,0 bar) AP: 3626 psia (250,0 bar)
---	---	--

(1) For SP Range 4 with DP Range 1, the URL is 2000 psi (137,9 bar).

(2) Inert fill: minimum pressure = 1.5 psia (0,10 bar) or -13.2 psig (-0,91 bar).

(3) Assumes atmospheric pressure of 14.7 psia (1 bar-a).

Transmitter is compatible with any Pt 100 RTD sensor. Examples of compatible RTDs include Rosemount Series 68 and 78 RTD Temperature Sensors.

Table 38: Process Temperature RTD Interface (3051SMV__1 or 3, 3051SF_1, 3, 5 or 7)

Lower (LRL)	Upper (URL)
-328 °F (-200 °C)	1562 °F (850 °C)

Minimum span limits

Table 39: Transmitter with Coplanar Sensor Module (Single Variable)

Range	DP Sensor ⁽¹⁾ (3051S_CD, 3051SMV__3 or 4, 3051SF_D, 3, 4 or 7, 3051SAL__CD ⁽²⁾)		GP Sensor (3051S_CG, 3051SAM__G ⁽³⁾ , 3051SAL__G ⁽²⁾⁽³⁾)		AP Sensor (3051S_CA, 3051SAM__A ⁽³⁾ , 3051SAL__A ⁽²⁾⁽³⁾)	
	Ultra and Ultra for Flow	Classic	Ultra	Classic	Ultra	Classic
0	0.10 inH ₂ O (0,25 mbar)	0.10 inH ₂ O (0,25 mbar)	N/A	N/A	0.167 psia (11,49 mbar)	0.167 psia (11,49 mbar)
1	0.50 inH ₂ O (1,24 mbar)	0.50 inH ₂ O (1,24 mbar)	0.50 inH ₂ O (1,24 mbar)	0.50 inH ₂ O (1,24 mbar)	0.30 psia (20,68 mbar)	0.30 psia (20,68 mbar)
2	1.25 inH ₂ O (3,11 mbar)	1.67 inH ₂ O (4,14 mbar)	1.25 inH ₂ O (3,11 mbar)	1.67 inH ₂ O (4,14 mbar)	0.75 psia (51,71 mbar)	1.00 psia (68,95 mbar)
3	1.0 inH ₂ O (2,49 mbar)	6.67 inH ₂ O (16,58 mbar)	1.0 inH ₂ O (2,49 mbar)	6.67 inH ₂ O (16,58 mbar)	4.00 psia (275,79 mbar)	5.33 psia (367,72 mbar)
4	1.50 psi (103,42 mbar)	2.00 psi (137,90 mbar)	1.50 psig (103,42 mbar)	2.00 psig (137,90 mbar)	20.00 psia (1,38 bar)	26.67 psia (1,84 bar)
5	10.00 psi (689,48 mbar)	13.33 psi (919,30 mbar)	10.00 psig (689,48 mbar)	13.33 psig (919,30 mbar)	N/A	N/A

(1) Rosemount 3051SF flow meters only available with ranges 1, 2, and 3.

(2) For Rosemount 3051SAL models, use Classic minimum span limits.

(3) Specifications are for each gage/absolute pressure sensor of the ERS system and are not reflective of the DP calculation.

Table 40: Transmitter with In-Line Sensor Module

Range	GP Sensor (3051S_TG, 3051SAM__T ⁽¹⁾ , 3051SAL__T ⁽²⁾)		AP Sensor (3051S_TA, 3051SAM__E ⁽¹⁾ , 3051SAL__E ⁽²⁾)	
	Ultra	Classic	Ultra	Classic
1	0.30 psig (20,68 mbar)	0.30 psig (20,68 mbar)	0.30 psia (20,68 mbar)	0.30 psia (20,68 mbar)
2	0.75 psig (51,71 mbar)	1.00 psig (68,95 mbar)	0.75 psia (51,71 mbar)	1.00 psia (68,95 mbar)
3	4.00 psig (275,79 mbar)	5.33 psig (367,72 mbar)	4.00 psia (275,79 mbar)	5.33 psia (367,72 mbar)

Table 40: Transmitter with In-Line Sensor Module (continued)

Range	GP Sensor (3051S_TG, 3051SAM__T ⁽¹⁾ , 3051SAL__T ⁽²⁾)		AP Sensor (3051S_TA, 3051SAM__E ⁽¹⁾ , 3051SAL__E ⁽²⁾)	
	Ultra	Classic	Ultra	Classic
4	20.00 psig (1,38 bar)	26.67 psig (1,84 bar)	20.00 psia (1,38 bar)	26.67 psia (1,84 bar)
5	1000.00 psig (68,95 bar)	2000.00 psig (137,90 bar)	1000.00 psia (68,95 bar)	2000.00 psia (137,90 bar)

(1) Specifications are for each gage/absolute pressure sensor of the ERS system and are not reflective of the DP calculation.

(2) For Rosemount 3051SAL models, use Classic minimum span limits.

Table 41: Transmitter with Multivariable Sensor Module (3051SMV__1 or 2, 3051SF_1, 2, 5, or 6)

Range	DP Sensor	
	Ultra for Flow	Classic MV
1	N/A	0.5 inH ₂ O (1,24 mbar)
2	1.3 inH ₂ O (3,23 mbar)	2.5 inH ₂ O (6,22 mbar)
3	5.0 inH ₂ O (12,43 mbar)	10.0 inH ₂ O (24,86 mbar)
4	1.5 psi (103,42 mbar)	3.0 psi (206,84 mbar)
5	N/A	20.0 psi (1,38 bar)
Range	Static Pressure Sensor (GP/AP)	
	Ultra for Flow	Classic MV
3	4.0 psi (275,79 mbar)	8.0 psi (551,58 mbar)
4	18.13 psi (1,25 bar)	36.26 psi (2,50 bar)

Process temperature RTD interface (3051SMV__1 or 3, 3051SF_1, 3, 5 or 7)

Minimum span = 50 °F (28 °C)

DP span considerations for ERS applications

It is recommended that the DP rangedown (operating pressure/DP span) for ERS applications not exceed 100:1. Consult with Emerson sales representative when considering a Rosemount 3051S ERS System for applications beyond 100:1 rangedown.

Service**Rosemount 3051S, 3051SMV_P, 3051SAM, and 3051SF_5, 6, 7, or D (Direct Process Variable Output)**

Liquid, gas, and vapor applications

Rosemount 3051SAL

Liquid level applications

Rosemount 3051SMV_M and 3051SF_1, 2, 3, or 4 (Mass and Energy Flow Output)**Note**

For option code A: 4-20mA HART only.

Some fluid types are only supported by certain measurement types.

Table 42: Fluid Compatibility with Pressure and Temperature Compensation

		Fluid types			
Ordering code	Measurement type	Liquids	Saturated steam	Superheated steam	Gas and natural gas
		1	DP/P/T (full compensation)	•	•
2	DP/P	•	•	•	•
3	DP/T	•	•	—	—
4	DP only	•	•	—	—

4–20 mA HART® protocol

Zero and span adjustment

Zero and span values can be set anywhere within the range. Span must be greater than or equal to the minimum span.

Output

The 2-wire 4–20 mA is user-selectable for linear or square root output. Digital process variable superimposed on 4–20 mA signal is available to any host that conforms to the HART protocol.

Power supply

External power supply required.

- Rosemount™ 3051S and 3051SF_D: 10.5 to 42.4 Vdc with no load
- Rosemount 3051S and 3051SF_D with Advanced HART Diagnostics Suite: 12 to 42.4 Vdc with no load
- Rosemount 3051SMV™ and 3051SF_1-7: 12 to 42.4 Vdc with no load
- Rosemount 3051S ERS™ System: 16.0 to 42.4 Vdc with no load

Load limitations

Maximum loop resistance is determined by the voltage level of the external power supply, as described by:

Figure 1: Rosemount 3051S and 3051SF_D

Maximum Loop Resistance = $43.5 \times (\text{Power Supply Voltage} - 10.5)$

The Field Communicator requires a minimum loop resistance of 250 Ω for communication.

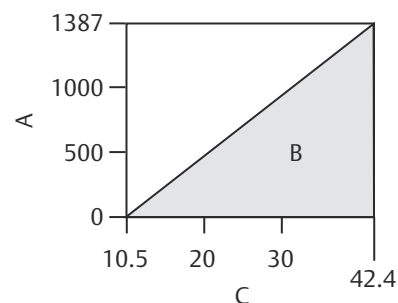

- A. Load (Ohms)
- B. Operating region
- C. Voltage (Vdc)

Figure 2: Rosemount 3051SMV and 3051SF_1-7, 3051S and 3051SF_D with HART Diagnostics (option code DA2)

Maximum Loop Resistance = $43.5 \times (\text{Power Supply Voltage} - 12.0)$

The Field Communicator requires a minimum loop resistance of 250 Ω for communication.

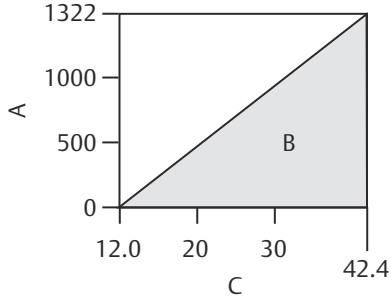

- A. Load (Ohms)
- B. Operating region
- C. Voltage (Vdc)

Figure 3: Rosemount 3051S ERS System

If supply voltage ≤ 16.74 Vdc: Maximum Loop Resistance = $277 \times (\text{Power Supply Voltage} - 16.0)$
 If supply voltage > 16.74 Vdc: Maximum Loop Resistance = $43.5 \times (\text{Power Supply Voltage} - 12.0)$

The Field Communicator requires a minimum loop resistance of 250 Ω for communication.

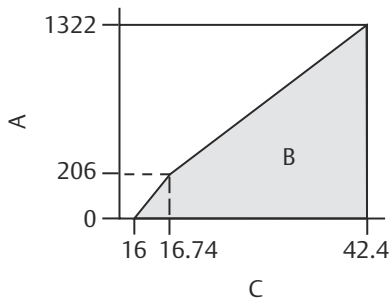

- A. Load (Ohms)
- B. Operating region
- C. Voltage (Vdc)

Selectable HART revisions (option code HR7)

The 2-wire 4–20 mA is user-selectable for linear or square root output. Digital process variable superimposed on 4–20 mA signal is available to any host that conforms to HART protocol. The Rosemount 3051S with Advanced HART Diagnostics (DA2) comes with Selectable HART revisions. Digital communications based on HART Revision 7 (with option code HR7 selected) or Revision 5 (default) protocol can be selected. The HART revision can be switched in the field using any HART-based configuration. See the Rosemount 3051S [Reference Manual](#) for instructions on how to switch HART revision.

Advanced HART diagnostics suite (Option Code DA2)

The Process Integrity diagnostic provides statistical data (standard deviation, mean, coefficient of variation) that can be used to detect process and process equipment anomalies including but not limited to:

- furnace flame instability
- pump cavitation
- distillation column flooding
- fluid composition change

- entrained air
- agitation loss
- process leak

This diagnostic allows you to take preventative measures before abnormal process situations result in unscheduled downtime or rework.

The Loop Integrity diagnostic pro-actively detects and notifies you of changes in the electrical loop before they affect your process operation. Example loop problems that can be detected include water in the terminal compartment, corrosion of terminals, improper grounding, and unstable power supplies.

The Plugged Impulse Line diagnostic uses the same statistical processing technology as Process Integrity to detect plugging in impulse piping that may prevent the transmitter from obtaining an accurate process reading. It can also detect and alert you to other process connection issues, such as plugged Annubar or orifice plate process taps.

The Device Dashboard presents the diagnostics in a graphical, task-based interface that provides single click access to critical process/device information and descriptive graphical troubleshooting.

Suite includes: Process Intelligence, Loop Integrity, Plugged Impulse Line, Status Log, Variable Log, Advanced Process Alerts, Service Alerts, and Time Stamp capability.

FOUNDATION™ Fieldbus protocol

Power supply

External power supply required; transmitters operate on 9.0–32.0 Vdc (9.0–17.5 Vdc for FISCO) transmitter terminal voltage.

Current draw

17.5 mA for all configurations (including LCD display option)

Parameters:

- Schedule entries: 22 (max.)
- Links: 25 (max.)
- Virtual Communications Relationships (VCR): 20 (max.)

Standard function blocks

Resource Block	Contains hardware, electronics, and diagnostic information.
Transducer Block	Contains actual sensor measurement data including the sensor diagnostics and the ability to trim the pressure sensor or recall factory defaults.
LCD display Block	Configures the local display.
Analog Input Blocks	Processes the measurements for input into other function blocks. The output value is in engineering or custom units and contains a status indicating measurement quality.
PID Block with Auto-tune	Contains all logic to perform PID control in the field including cascade and feedforward. Auto-tune capability allows for superior tuning for optimized control performance.

Backup Link Active Scheduler (LAS)

The transmitter can function as a Link Active Scheduler if the current link master device fails or is removed from the segment.

Software upgrade in the field

Software for the Rosemount™ 3051S with FOUNDATION Fieldbus is easy to upgrade in the field using the FOUNDATION Fieldbus Common Device Software Download procedure.

Plantweb alerts

Enable the full power of the Plantweb™ digital architecture by diagnosing instrumentation issues, communicating advisory, maintenance, and failure details, and recommending a solution.

Advanced control function block suite (option code A01)

- Input selector block** Selects between inputs and generates an output using specific selection strategies such as minimum, maximum, midpoint, average, or first “good.”
- Arithmetic block** Provides pre-defined application-based equations including flow with partial density compensation, electronic remote sensors, hydrostatic tank gauging, ratio control and others.
- Signal characterizer block** Characterizes or approximates any function that defines an input/output relationship by configuring up to twenty X, Y coordinates. The block interpolates an output value for a given input value using the curve defined by the configured coordinates.
- Integrator block** Compares the integrated or accumulated value from one or two variables to pre-trip and trip limits and generates discrete output signals when the limits are reached. This block is useful for calculating total flow, total mass, or volume over time.
- Output splitter block** Splits the output of one PID or other control block so that the PID will control two valves or other actuators.
- Control selector block** Selects one of up to three inputs (highest, middle, or lowest) that are normally connected to the outputs of PID or other control function blocks.

Block	Execution time
Resource	N/A
Transducer	N/A
LCD Display Block	N/A
Analog Input 1	20 milliseconds
PID with Auto-tune	35 milliseconds
Input Selector	20 milliseconds
Arithmetic	20 milliseconds
Signal Characterizer	20 milliseconds
Integrator	20 milliseconds
Output Splitter	20 milliseconds
Control Selector	20 milliseconds

FOUNDATION Fieldbus diagnostics suite (option code D01)

Note

Only applies to Rosemount 3051S with transmitter output code F.

Process Intelligence provides statistical data (standard deviation and mean) that can be used to detect process and process equipment anomalies, including:

- furnace flame instability
- pump cavitation
- distillation column flooding
- fluid composition change

- entrained air
- agitation loss
- process leak

This diagnostic allows you to take preventative measures before abnormal process situations result in unscheduled downtime or rework.

The Plugged Impulse Line diagnostic uses the same statistical processing technology as Process Intelligence to detect plugging in impulse piping that may prevent the transmitter from obtaining an accurate process reading. It can also detect and alert you to other process connection issues, such as plugged Annubar or orifice plate process taps.

The Device Dashboard presents the diagnostics in a graphical, task-based interface that provides single click access to critical process/device information and descriptive graphical troubleshooting.

Suite includes: Process Intelligence and Plugged Impulse Line diagnostics.

IEC 62591 (*WirelessHART*[®] protocol)

Output

IEC 62591 (*WirelessHART*), 2.4 GHz DSSS

Radio frequency power output from antenna

- External antenna (WK option): Maximum of 10 mW (10 dBm) EIRP
- Extended range, external antenna (WM option): Maximum of 18 mW (12.5 dBm) EIRP
- Remote (WJ option) antenna: Maximum of 17 mW (12.3 dBm) EIRP
- High-gain, remote antenna (WN option): Maximum of 40 mW (16 dBm) EIRP

Local display

The optional seven-digit LCD display can display user-selectable information such as primary variable in engineering units, percent of range, sensor module temperature, and electronics temperature. The display updates based on the wireless update rate.

Update rate

User selectable 1 second to 60 minutes.

Power module

Field replaceable, keyed connection eliminates the risk of incorrect installation, Intrinsically Safe Lithium-thionyl chloride Power Module with polybutadine terephthalate (PBT) enclosure. Ten-year life at one minute update rate.⁽¹⁾⁽²⁾

Overpressure limits

Transmitters withstand the following limits without damage:

(1) Reference conditions are 70 °F (21 °C), and routing data for three additional network devices. Note: Continuous exposure to ambient temperature limits of -40 °F or 185 °F (-40 °C or 85 °C) may reduce specified life by less than 20 percent.

(2) 6.5-year life at one minute update rates when used with 3051SMV.

Table 43: Coplanar Sensor Module (Single Variable)

Range	DP ⁽¹⁾ and GP	AP
	3051S_CD, 3051S_CG 3051SMV__3 or 4 3051SF_3, 4, 7, or D 3051SAM__G	3051S_CA 3051SAM__A
0	750 psi (51,71 bar)	60 psia (4,14 bar)
1	2000 psi (137,90 bar)	750 psia (51,71 bar)
2	3626 psi (250,00 bar)	1500 psia (103,42 bar)
3	3626 psi (250,00 bar)	1600 psia (110,32 bar)
4	3626 psi (250,00 bar)	6000 psia (413,69 bar)
5	3626 psi (250,00 bar)	N/A

(1) The overpressure limit of a DP Sensor with the P9 option is 4500 psig (310,3 bar). The overpressure limit of a DP Sensor with the P0 option is 6092 psig (420 bar).

Table 44: In-Line Sensor Module

Range	GP	AP
	3051S_TG 3051SAM__T	3051S_TA 3051SAM__E
1	750 psi (51,71 bar)	
2	1500 psi (103,42 bar)	
3	1600 psi (110,32 bar)	
4	6000 psi (413,69 bar)	
5	15000 psi (1034,21 bar)	

Coplanar multivariable sensor module (3051SMV__1 or 2, 3051SF_1, 2, 5, or 6)

DP Range	Static Pressure Range (GP/AP)	
	3	4
1	1600 psi (110,32 bar)	2000 psi (137,90 bar)
2	1600 psi (110,32 bar)	3626 psi (250,00 bar)
3	1600 psi (110,32 bar)	3626 psi (250,00 bar)
4	N/A	3626 psi (250,00 bar)
5	N/A	3626 psi (250,00 bar)

Liquid level transmitter (Rosemount 3051SAL)

Overpressure limit is dependent on the flange rating or sensor rating (whichever is lower). Use Instrument Toolkit to ensure the seal system meets all pressure and temperature limits.

Static pressure limits**Coplanar sensor module (single variable)**

Operates within specifications between static line pressures of:

Range	DP Sensor ⁽¹⁾
	3051S_CD
	3051SMV__3 or 4 3051SF_3, 4, 7, or D
0	0.5 psia to 750 psig (0,03 to 51,71 bar)
1	0.5 psia to 2000 psig (0,03 to 137,90 bar)
2	0.5 psia to 3626 psig (0,03 to 250,00 bar)
3	0.5 psia to 3626 psig (0,03 to 250,00 bar)
4	0.5 psia to 3626 psig (0,03 to 250,00 bar)
5	0.5 psia to 3626 psig (0,03 to 250,00 bar)

(1) The static pressure limit of a DP Sensor with the P9 option is 4500 psig (310,26 bar). The static pressure limit of a DP Sensor with the P0 option is 6092 psig (420,00 bar).

Coplanar multivariable sensor module

(3051SMV__1 or 2, 3051SF_1, 2, 5, or 6)

Operates within specifications between static line pressures of 0.5 psia (0,03 bar) and the values in the table below:

DP Range	Static Pressure Range (GP/AP)	
	3	4
1	800 psi (55,15 bar)	2000 psi (137,90 bar)
2	800 psi (55,15 bar)	3626 psi (250,00 bar)
3	800 psi (55,15 bar)	3626 psi (250,00 bar)
4	N/A	3626 psi (250,00 bar)
5	N/A	3626 psi (250,00 bar)

Maximum working pressure limits

Maximum working pressure is the maximum pressure allowed for normal transmitter operation. For a differential pressure transmitter, the maximum working pressure is the static line pressure under which the transmitter can safely operate. If one side of the transmitter is exposed to the full static line pressure due to mis-valving, the transmitter will experience an output shift and must be re-zeroed. For a gage or absolute pressure transmitter, the maximum working pressure is the same as the Upper Range Limit (URL). The maximum working pressure of transmitters with assemble-to options is limited by the lowest maximum pressure rating of the individual components.

Table 45: Rosemount 3051S Maximum Working Pressure

Range	3051S_CD 3051SAL__D 3051SAM__D	3051S_CG 3051SAL__G 3051SAM__G	3051S_CA 3051SAL__A 3051SAM__A	3051S_TA 3051SAL__E 3051SAM__E	3051S_TG 3051SAL__T 3051SAM__T
0	750 psi 51.7 bar 5.17 mpa	N/A	5 psia 0.35 bar-a .035 mpa	N/A	N/A
1	2000 psi 138 bar 13.8 mpa	0.9 psi 0.062 bar 0.0062 mpa	30 psia 2.07 bar-a 0.207 mpa	30 psia 2.07 bar-a 0.207 mpa	30 psi 2.07 bar-a 0.207 mpa

Table 45: Rosemount 3051S Maximum Working Pressure (continued)

Range	3051S_CD 3051SAL__D 3051SAM__D	3051S_CG 3051SAL__G 3051SAM__G	3051S_CA 3051SAL__A 3051SAM__A	3051S_TA 3051SAL__E 3051SAM__E	3051S_TG 3051SAL__T 3051SAM__T
2	3626 psi 250 bar 25 mpa	9 psi 0.62 bar 0.062 mpa	150 psia 10.3 bar-a 1.03 mpa	150 psia 10.3 bar-a 1.03 mpa	150 psi 10.3 bar-a 1.03 mpa
3	3626 psi 250 bar 25 mpa	36 psi 2.48 bar 0.248 mpa	800 psia 55.2 bar-a 5.52 mpa	800 psia 55.2 bar-a 5.52 mpa	800 psi 55.2 bar-a 5.52 mpa
4	3626 psi 250 bar 25 mpa	300 psi 20.7 bar 2.07 mpa	4000 psia 276 bar-a 27.6 mpa	4000 psia 276 bar-a 27.6 mpa	4000 psi 276 bar-a 27.6 mpa
5	3626 psi 250 bar 25 mpa	2000 psi 138 bar 13.8 mpa	N/A	10000psia 690 bar-a 69.0 mpa	10000 psi 690 bar-a 69.0 mpa

Note

The maximum working pressure limit of a DP Sensor with the P9 option is 4500 psig (310,26 bar). The maximum working pressure limit of a DP Sensor with the P0 option is 6092 psig (420,00 bar).

Table 46: Rosemount 3051SMV Maximum Working Pressure (3051SMV1M1[X]G[Y]R2E12A1A)

X = DP Range	Y = 3 (GP/AP Range)	Y = 4 (GP/AP Range)
1	800 psi 55.2 bar 5.52 mpa	2000 psi 138 bar 13.8 mpa
2	800 psi 55.2 bar 5.52 mpa	3626 psi 250 bar 25 mpa
3	800 psi 55.2 bar 5.52 mpa	3626 psi 250 bar 25 mpa
4 and 5	N/A	3626 psi 250 bar 25 mpa

Burst pressure limits

Coplanar sensor module (3051S_C, 3051SMV, 3051SF, 3051SAM__G or A)

10000 psig (689,47 bar)

In-line sensor module (3051S_T, 3051SAM_T or E)

- Ranges 1-4: 11000 psi (758,42 bar)
- Range 5: 26000 psi (1792,64 bar)

Temperature limits**Ambient**

-40 to 185 °F (-40 to 85 °C)

With LCD display⁽³⁾: -40 to 176 °F (-40 to 80 °C)

With option code P0: -20 to 185 °F (-28 to 85 °C)

With option code BR6: -76 to 185 °F (-60 to 85 °C)

Storage

-50 to 185 °F (-46 to 85 °C)

With LCD display: -40 to 185 °F (-40 to 85 °C)

With wireless output: -40 to 185 °F (-40 to 85 °C)

With option code BR6: -76 to 185 °F (-60 to 85 °C)

Process temperature limits

At atmospheric pressures and above:

Coplanar sensor module	
3051S_C, 3051SMV, 3051SF, 3051SAM_G or A	
Silicone fill sensor	N/A
with coplanar flange ⁽¹⁾	-40 to 250 °F (-40 to 121 °C) ⁽²⁾
with traditional flange ⁽³⁾	-40 to 300 °F (-40 to 149 °C) ⁽²⁾⁽⁴⁾
with level flange ⁽³⁾	-40 to 300 °F (-40 to 149 °C) ⁽²⁾
with Rosemount™ 305 integral manifold ⁽¹⁾	-40 to 300 °F (-40 to 149 °C) ⁽²⁾⁽⁴⁾
Inert fill sensor ⁽¹⁾	-40 to 185 °F (-40 to 85 °C) ⁽⁵⁾⁽⁶⁾
with Option Code BR6, coplanar flange	-76 to 250 °F (-60 to 121 °C) ⁽²⁾
with Option Code BR6, traditional flange	-75 to 300 °F (-60 to 149 °C) ⁽²⁾
In-line sensor module	
3051S_T, 3051SAM_T or E	
Silicone fill sensor ⁽¹⁾	-40 to 250 °F (-40 to 121 °C) ⁽²⁾
with Option Code BR6	-76 to 250 °F (-60 to 121 °C) ⁽²⁾
Inert fill sensor ⁽¹⁾	-22 to 250 °F (-30 to 121 °C) ⁽²⁾
Rosemount™ 3051SAL Level Transmitter	
SYL THERM™ XLT	-157 to 293 °F (-105 to 145 °C)

⁽³⁾ LCD display may not be readable and LCD display updates will be slower at temperatures below -4 °F (-20 °C).

Silicone 704 ⁽⁷⁾	32 to 599 °F (0 to 315 °C)
Silicone 705 ⁽⁷⁾	68 to 698 °F (20 to 370 °C)
UltraTherm™ 805	770 °F (410 °C) with 850 °F (454 °C) design ⁽⁸⁾
Silicone 200	-49 to 401 °F (-45 to 205 °C)
Tri-Therm 300	-40 to 401 °F (-40 to 205 °C)
Inert (Halocarbon)	-49 to 320 °F (-45 to 160 °C)
Glycerin and water ⁽⁹⁾⁽¹⁰⁾	5 to 203 °F (-15 to 95 °C)
Neobee® M-20 ⁽⁹⁾	5 to 437 °F (-15 to 225 °C)
Propylene glycol and water ⁽⁹⁾⁽¹⁰⁾	5 to 203 °F (-15 to 95 °C)

- (1) The maximum ambient temperature is reduced by 1.5° for every degree by which the process fluid temperature exceeds 185 °F (85 °C).
- (2) 220 °F (104 °C) limit in vacuum service; 130 °F (54 °C) for pressures below 0.5 psia.
- (3) The maximum ambient temperature is reduced by 1.0° for every degree by which the process fluid temperature exceeds 185 °F (85 °C) for all traditional flanges and vertical mount level flanges.
- (4) -20 °F (-29 °C) is the lower process temperature limit with option code P0.
- (5) 160 °F (71 °C) limit in vacuum service.
- (6) Not available for 3051S_CA.
- (7) Only available with Seal Connection Type/Capillary ID, Description Codes C, D, F, G, J, K, N, and P.
- (8) UltraTherm 805 supports maximum design temperature of 850 °F (454 °C). Design temperature rating is for non-continuous use with a cumulative exposure time less of than 12 hours. Continuous use temperature is rated to 770 °F (410 °C).
- (9) This is a food grade fill fluid.
- (10) Not suitable for vacuum applications.

Thermal Range Expander temperature operating range

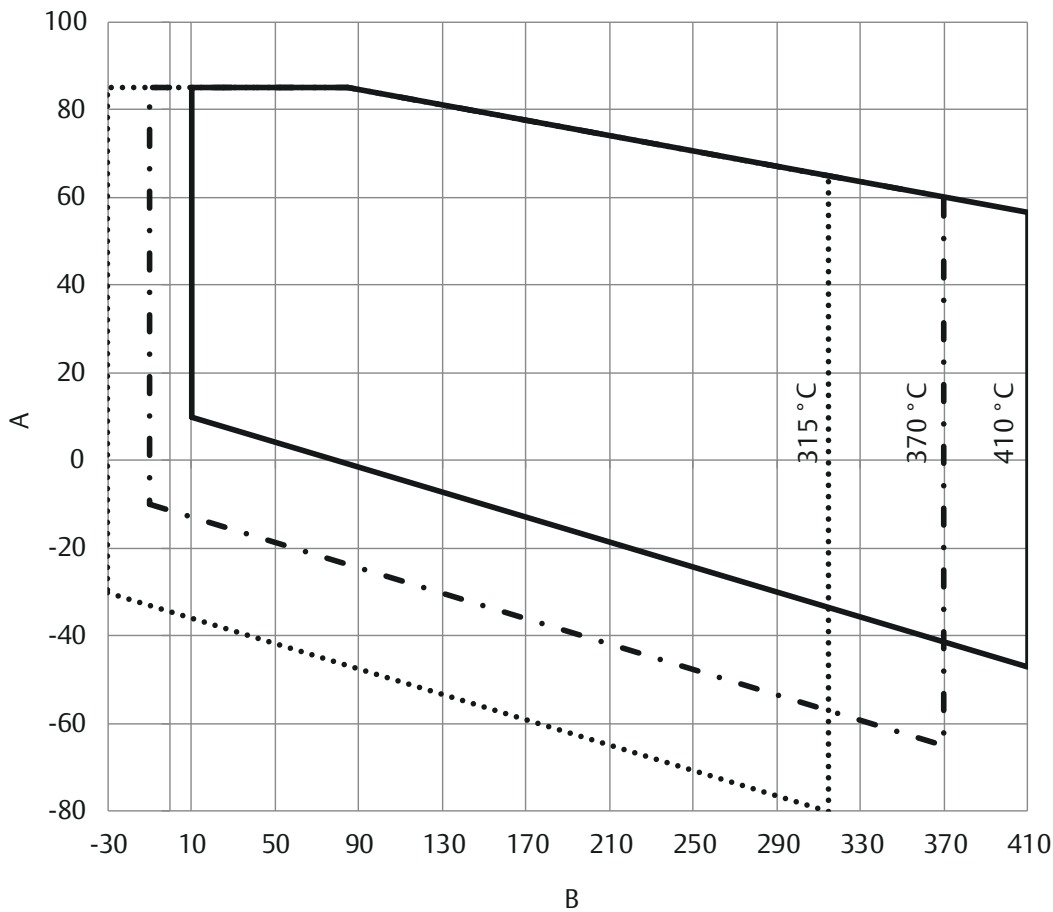

- Silicone 704
- Silicone 705
- UltraTherm 805
- A. Ambient temperature (°C)
- B. Process temperature (°C)

Humidity limits

0–100% relative humidity

Turn-on time

When power is applied to the transmitter during startup, performance will be within specifications per the time period described below:

Note

Does not apply to wireless option code X.

For option code F, device will communicate on a segment in less than 20 seconds.

Transmitter	Turn-on time (typical)
3051S, 3051SF_D, 3051SAL__C	2 seconds
Diagnostics	5 seconds
3051SMV, 3051SF_1-7	5 seconds
3051S ERS System	6 seconds

Volumetric displacement

Less than 0.005 in³ (0,08 cm³)

Damping

Note

Does not apply to wireless option code X.

Analog output response time to a step change is user-selectable from 0 to 60 seconds for one time constant. For Rosemount 3051SMV, 3051SF_1-7, each variable can be individually adjusted. Software damping is in addition to sensor module response time.

Failure mode alarm

4–20 mA HART (output option code A)

If self-diagnostics detect a gross transmitter failure, the analog signal will be driven offscale to alert the user. Rosemount standard (default), NAMUR, and custom alarm levels are available (see [Alarm configuration](#)).

High or low alarm signal is software-selectable or hardware-selectable via the optional switch (option D1).

Alarm configuration

Configuration	High alarm	Low alarm
Default	≥ 21.75 mA	≤ 3.75 mA
NAMUR compliant ⁽¹⁾	≥ 22.5 mA	≤ 3.6 mA
Custom levels ⁽²⁾⁽³⁾	20.2 - 23.0 mA	3.4 - 3.8 mA

(1) Analog output levels are compliant with NAMUR recommendation NE 43, see option codes C4 or C5.

(2) Low alarm must be 0.1 mA less than low saturation and high alarm must be 0.1 mA greater than high saturation.

(3) For Rosemount 3051SMV and option code DA2, low alarm custom values are 3.57 - 3.8 mA.

Physical specifications

Material selection

Emerson™ provides a variety of Rosemount™ products with various product options and configurations including materials of construction that can be expected to perform well in a wide range of applications. The Rosemount product information presented is intended as a guide for the purchaser to make an appropriate selection for the application. It is the purchaser's sole responsibility to make a careful analysis of all process parameters (such as all chemical components, temperature, pressure, flow rate, abrasives, contaminants, etc.), when specifying product, materials, options and components for the particular application. Emerson is not in a position to evaluate or guarantee the compatibility of the process fluid or other process parameters with the product, options, configuration or materials of construction selected.

Electrical connections

½–14 NPT, G½, and M20 × 1½ conduit. HART® interface connections fixed to terminal block for Output code A and X.

Process connections

Coplanar sensor module (3051S_C, 3051SMV, 3051SF, 3051SAM__G or A)	
Standard	¼–18 NPT on 2½-in. centers
Flange Adapters	½–14 NPT and RC½ on 2-in. (50.8 mm), 2⅛-in. (54.0 mm), or 2¼-in. (57.2 mm) centers
In-line sensor module (3051S_T, 3051SAM__T or E)	
Standard	½–14 NPT Female
F11 Code	Non-threaded instrument flange (available in SST for sensor ranges 1–4 only)
G11 Code	G½ A DIN 16288 male (available in SST for sensor ranges 1–4 only)
H11 Code	Autoclave type F-250C (Pressure relieved 9/16–18 gland thread; ¼ OD high pressure tube 60° cone; available in SST for sensor range 5 only)
Level transmitter (Rosemount 3051SAL)	
FF Seal	2-in. (DN 50), 3-in. (DN 80), or 4-in. (DN 100); ANSI Class 150, 300, 600, 900, 1500, and 2500 flange; JIS 10K, 20K, or 40K flange; PN 10/16 or PN 40 flange
PF Seal	
EF Seal	
RF Seal	1-in. (DN 25) or 1½-in. (DN 40); ANSI Class 150, 300, or 600 flange; JIS 10K, 20K, or 40K flange; PN 40 flange
RT Seal	¼–18, ½–14, ¾–14, or 1–11.5 NPT Female
FC Seal	2-in. or 3-in.; ANSI Class 150, 300, 600, 900, 1500, 2500 flange; PN 63 or PN 100 flange
RC Seal	½-in., ¾-in., 1-in., or 1½-in.; ANSI Class 150, 300, 600, 900, 1500, 2500 flange; PN 63 or PN 100 flange
SC Seal	1½-in, 2-in, or 3-in. Hygienic Tri-Clover Style Tri Clamp
SS Seal	4-in. Hygienic Tank Spud

Process-wetted parts

Process isolating diaphragms

Coplanar sensor module (3051S_C, 3051SMV)	
316L SST (UNS S31603), Alloy C-276 (UNS N10276), Alloy 400 (UNS N04400), Tantalum (UNS R05440), Gold-Plated Alloy 400, Gold-plated 316L SST	
B11 Code	Low side process connection is SST
In-line sensor module (3051S_T)	
316L SST (UNS S31603), Alloy C-276 (UNS N10276)	
Level transmitter (Rosemount 3051SAL)	
FF Seal	316L SST, Alloy C-276, Tantalum
EF Seal	
RF Seal	
RT Seal	
PF Seal	

FC Seal	316L SST, Alloy C-276
RC Seal	
SC Seal	
SS Seal	

Drain/vent valves

316 SST, Alloy C-276, or Alloy 400/K-500⁽⁴⁾ material

(Drain vent seat: Alloy 400, Drain vent stem: Alloy K-500)

Process flanges and flange adapters

Plated carbon steel

SST: CF-8M (Cast 316 SST) per ASTM A743

Cast C-276: CW-12MW per ASTM A494

Cast Alloy 400: M-30C per ASTM A494

Wetted O-rings

Glass-filled PTFE (Graphite-filled PTFE with isolating diaphragm code 6)

Rosemount 3051SAL mounting flange

Zinc-cobalt plated CS or 316 SST

Rosemount 3051SAL seal extension

CF-3M (Cast 316L SST, material per ASTM A743) or CW-12MW (Cast C-276, material per ASTM A494)

Non-wetted parts

Electronics housing

Low-copper aluminum alloy or CF-8M (Cast 316 SST)

Enclosures meet NEMA[®] Type 4X, IP66, and IP68 [66 ft (20 m) for 168 hours] when properly installed.

Note

IP 68 not available with Wireless output.

Coplanar sensor module housing

SST: CF-3M (Cast 316L SST)

Bolts

Plated carbon steel per ASTM A449, Type 1

Austenitic 316 SST per ASTM F593

ASTM A453, Class D, Grade 660 SST

⁽⁴⁾ Alloy 400/K-500 is not available with Rosemount 3051SAL.

ASTM A193, Grade B7M alloy steel

ASTM A193, Class 2, Grade B8M SST

Alloy K-500

Sensor module fill fluid

Silicone is standard.

Inert is available as option code (L1).⁽⁵⁾

Inert for in-line series uses Fluorinert™ FC-43.

Inert for coplanar series uses Halocarbon

Seal fill fluid (liquid level only)

Rosemount 3051SAL: Silicone 200, Tri-Therm 300, Silicone 704, Silicone 705, UltraTherm 805, inert, SYLTHERM™ XLT, Neobee® M-20, glycerin and water, propylene glycol and water.

Paint for aluminum housing

Polyurethane

Cover O-rings

Buna-N

Wireless antenna

External antenna (WK/WM): PBT/PC integrated omni-directional antenna

Remote antenna (WN): Fiberglass omni-directional antenna

Power module

Field replaceable, keyed connection eliminates the risk of incorrect installation, Intrinsically Safe Lithium-thionyl chloride Power module with PBT enclosure

Shipping weights

Table 47: Sensor modules

Coplanar sensor module⁽¹⁾	
3.1 lb (1,4 kg)	
In-line sensor module	
1.4 lb (0,6 kg)	

(1) Flange and bolts not included.

Fully functional transmitter with module, terminal block, standard covers, and connector board, if applicable.

Table 48: Transmitters

Transmitter with coplanar sensor module (3051S_C, 3051SMV, 3051SAM__G or A)	
Junction Box housing, SST Flange	6.3 lb (2,8 kg)

(5) Inert is not available with Rosemount™ 3051S_CA.

Table 48: Transmitters (continued)

Transmitter with coplanar sensor module (3051S_C, 3051SMV, 3051SAM__G or A)	
Plantweb™ housing, SST Flange	6.7 lb (3,1 kg)
Wireless Plantweb housing, SST Flange	7.3 lb (3,3 kg)
Transmitter with in-line sensor module (3051S_T, 3051SAM__T or E)	
Junction Box housing	3.2 lb (1,4 kg)
Plantweb housing	3.7 lb (1,7 kg)
Wireless Plantweb housing	4.2 lb (1,9 kg)

Table 49: Transmitter options

Option code	Option	Add lb (kg)
1J, 1K, 1L	SST Plantweb housing	3.5 (1,6)
2J	SST junction box housing	3.4 (1,5)
7J	SST quick connect	0.4 (0,2)
2A, 2B, 2C	Aluminum junction box housing	1.1 (0,5)
1A, 1B, 1C	Aluminum Plantweb housing	1.1 (0,5)
M5 ⁽¹⁾	LCD display for aluminum Plantweb housing	0.8 (0,4)
	LCD display for SST Plantweb housing	1.6 (0,7)
B4	SST mounting bracket for coplanar flange	1.2 (0,5)
B1, B2, B3	Mounting bracket for traditional flange	1.7 (0,8)
B7, B8, B9	Mounting bracket for traditional flange with SST Bolts	1.7 (0,8)
BA, BC	SST bracket for traditional flange	1.6 (0,7)
B4	SST mounting Bracket for in-line	1.3 (0,6)
F12, F22 ⁽²⁾	SST traditional flange with SST Drain Vents	3.2 (1,5)
F13, F23 ⁽²⁾	Cast C-276 traditional flange with Alloy C-276 Drain Vents	3.6 (1,6)
E12, E22 ⁽²⁾	SST coplanar Flange with SST Drain Vents	1.9 (0,9)
F14, F24 ⁽²⁾	Cast Alloy 400 traditional flange with Alloy 400/K-500 Drain Vents	3.6 (1,6)
F15, F25 ⁽²⁾	SST traditional flange with Alloy C-276 Drain Vents	3.2 (1,5)
G21	Level flange (3-in., Class 150)	12.6 (5,7)
G22	Level flange (3-in., Class 300)	15.9 (7,2)
G11	Level flange (2-in., Class 150)	6.8 (3,1)
G12	Level flange (2-in., Class 300)	8.2 (3,7)
G31	DIN level flange, SST, DN 50, PN 40	7.8 (3,5)
G41	DIN level flange, SST, DN 80, PN 40	13.0 (5,9)

(1) Includes LCD display and display cover.

(2) Includes mounting bolts.

Table 50: Transmitter components

Item	Weight in lb. (kg)
Aluminum standard cover	0.4 (0,2)
SST standard cover	1.3 (0,6)
Aluminum display cover	0.7 (0,3)
SST display cover	1.5 (0,7)
Wireless extended cover	0.7 (0,3)
LCD display ⁽¹⁾	0.1 (0,04)
Junction box terminal block	0.2 (0,1)
Plantweb terminal block	0.2 (0,1)
Power module	0.5 (0,2)

(1) Display only.

Table 51: Rosemount 3051SAL without SuperModule™ platform, housing, or transmitter options

Flange	Flush lb. (kg)	2-in. Ext. lb (kg)	4-in. Ext. lb (kg)	6-in. Ext. lb (kg)
2-in., Class 150	9.5 (4,3)	N/A	N/A	N/A
3-in., Class 150	15.7 (7,1)	16.4 (7,4)	17.6 (8,0)	18.9 (8,6)
4-in., Class 150	21.2 (9,6)	20.9 (9,5)	22.1 (10,0)	23.4 (10,6)
2-in., Class 300	11.3 (5,1)	N/A	N/A	N/A
3-in., Class 300	19.6 (8,9)	20.3 (9,2)	21.5 (9,8)	22.8 (10,3)
4-in., Class 300	30.4 (13,8)	30.3 (13,7)	31.5 (14,3)	32.8 (14,9)
2-in., Class 600	12.8 (5,8)	N/A	N/A	N/A
3-in., Class 600	22.1 (10,0)	22.8 (10,3)	24.0 (10,9)	25.3 (11,5)
DN 50/PN 40	11.3 (5,1)	N/A	N/A	N/A
DN 80/PN 40	16.0 (7,3)	16.7 (7,6)	17.9 (8,1)	19.2 (8,7)
DN 100/PN 10/16	11.2 (5,1)	11.9 (5,4)	13.1 (5,9)	14.4 (6,5)
DN 100/PN 40	12.6 (5,7)	13.3 (6,0)	14.5 (6,6)	15.8 (7,1)

Product Certifications

Rosemount 3051S/3051SFx/3051S-ERS

Rev 1.18

European Directive Information

A copy of the EU Declaration of Conformity can be found at the end of the Quick Start Guide. The most recent revision of the EU Declaration of Conformity can be found at Emerson.com/Rosemount.

Ordinary Location Certification

As standard, the transmitter has been examined and tested to determine that the design meets the basic electrical, mechanical, and fire protection requirements by a nationally recognized test laboratory (NRTL) as accredited by the Federal Occupational Safety and Health Administration (OSHA).

Installing Equipment in North America

The US National Electrical Code (NEC[®]) and the Canadian Electrical Code (CEC) permit the use of Division marked equipment in Zones and Zone marked equipment in Divisions. The markings must be suitable for the area classification, gas, and temperature class. This information is clearly defined in the respective codes.

USA

E5 US Explosionproof (XP) and Dust-Ignitionproof (DIP)

Certificate FM16US0090

Standards FM Class 3600 - 2011, FM Class 3615 - 2006, FM Class 3616 - 2011, FM Class 3810 - 2005, ANSI/NEMA 250 - 2003

Markings XP CL I, DIV 1, GP B, C, D; DIP CL II, DIV 1, GP E, F, G; CL III; T5(-50 °C ≤ T_a ≤ +85 °C); Factory Sealed; Type 4X

I5 US Intrinsic Safety (IS) and Nonincendive (NI)

Certificate FM16US0089X

Standards FM Class 3600 - 2011, FM Class 3610 - 2010, FM Class 3611 - 2004, FM Class 3810 - 2005, NEMA[®] 250 - 2003

Markings IS CL I, DIV 1, GP A, B, C, D; CL II, DIV 1, GP E, F, G; Class III; Class 1, Zone 0 AEx ia IIC T4; NI CL 1, DIV 2, GP A, B, C, D; T4(-50 °C ≤ T_a ≤ +70 °C) [HART]; T4(-50 °C ≤ T_a ≤ +60 °C) [Fieldbus]; when connected per Rosemount drawing 03151-1006; Type 4X

Special Condition for Safe Use:

1. The Model 3051S/3051S-ERS Pressure Transmitter contains aluminum and is considered to constitute a potential risk of ignition by impact or friction. Care must be taken into account during installation and use to prevent impact and friction.

Note

Transmitters marked with NI CL 1, DIV 2 can be installed in Division 2 locations using general Division 2 wiring methods or Nonincendive Field Wiring (NIFW). See Drawing 03151-1006.

IE US FISCO Intrinsically Safe

Certificate FM16US0089X

Standards FM Class 3600 - 2011, FM Class 3610 - 2010, FM Class 3611 - 2004, FM Class 3810 - 2005, NEMA 250 - 2003

Markings IS CL I, DIV 1, GP A, B, C, D; T4(-50 °C ≤ T_a ≤ +60 °C); when connected per Rosemount drawing 03151-1006; Type 4X

Special Condition for Safe Use:

1. The Rosemount 3051S/3051S-ERS Pressure Transmitter contains aluminum and is considered to constitute a potential risk of ignition by impact or friction. Care must be taken into account during installation and use to prevent impact and friction.

Canada

E6 Canada Explosionproof, Dust-Ignitionproof, and Division 2

Certificate 1143113

Standards CAN/CSA C22.2 No. 0-10, CSA Std C22.2 No. 25-1966, CSA Std C22.2 No. 30-M1986, CAN/CSA C22.2 No. 94-M91, CSA Std C22.2 No. 142-M1987, CSA Std C22.2 No. 213-M1987, ANSI/ISA 12.27.01-2003, CSA Std C22.2 No. 60529:05

Markings Explosionproof Class I, Division 1, Groups B, C, D; Dust-Ignitionproof Class II, Division 1, Groups E, F, G; Class III; suitable for Class I, Zone 1, Group IIB+H2, T5; suitable for Class I, Division 2, Groups A, B, C, D; suitable for Class I, Zone 2, Group IIC, T5; when connected per Rosemount drawing 03151-1013; Type 4X

I6 Canada Intrinsically Safe

Certificate 1143113

Standards CAN/CSA C22.2 No. 0-10, CSA Std C22.2 No. 25-1966, CSA Std C22.2 No. 30-M1986, CAN/CSA C22.2 No. 94-M91, CSA Std C22.2 No. 142-M1987, CSA Std C22.2 No. 157-92, ANSI/ISA 12.27.01-2003, CSA Std C22.2 No. 60529:05

Markings Intrinsically Safe Class I, Division 1; Groups A, B, C, D; suitable for Class 1, Zone 0, IIC, T3C; when connected per Rosemount drawing 03151-1016 [3051S] 03151-1313 [ERS]; Type 4X

IF Canada FISCO

Certificate 1143113

Standards CAN/CSA C22.2 No. 0-10, CSA Std C22.2 No. 30-M1986, CAN/CSA C22.2 No. 94-M91, CSA Std C22.2 No. 142-M1987, CSA Std C22.2 No. 157-92, ANSI/ISA 12.27.01-2003, CSA Std C22.2 No. 60529:05

Markings FISCO Intrinsically Safe Class I, Division 1; Groups A, B, C, D; suitable for Class 1, Zone 0, IIC, T3C; when connected per Rosemount drawing 03151-1016 [3051S] 03151-1313 [ERS]; Type 4X

Europe

E1 ATEX Flameproof

Certificate KEMA 00ATEX2143X

Standards EN 60079-0:2012+A11:2013, EN 60079-1:2014, EN 60079-26:2015

Markings 

II 1/2 G Ex db IIC T6...T4 Ga/Gb, T6(-60 °C ≤ T_a ≤ +70 °C), T5/T4(-60 °C ≤ T_a ≤ +80 °C)

Table 52: Process Temperature

Temperature class	Process temperature
T6	-60 °C to +70 °C
T5	-60 °C to +80 °C
T4	-60 °C to +120 °C

Special Conditions for Safe Use (X):

1. This device contains a thin wall diaphragm less than 1 mm thickness that forms a boundary between Category 1 (process connection) and Category 2 (all other parts of the equipment). The model code and datasheet are to be consulted for details of the diaphragm material. Installation, maintenance and use shall take into account the environmental conditions to which the diaphragm will be subjected. The manufacturer's instructions for installation and maintenance shall be followed in detail to assure safety during its expected lifetime.
2. Flameproof joints are not intended for repair.
3. Non-standard paint options may cause risk from electrostatic discharge. Avoid installations that could cause electrostatic build-up on painted surfaces, and only clean the painted surfaces with a damp cloth. If paint is ordered through a special option code, contact the manufacturer for more information.
4. Appropriate cable, glands and plugs need to be suitable for a temperature of 5 °C greater than maximum specified temperature for location where installed.

I1 ATEX Intrinsic Safety

Certificate BAS01ATEX1303X

Standards EN 60079-0: 2012+A11:2013, EN 60079-11: 2012

Markings 

II 1 G Ex ia IIC T4 Ga, T4(-60 °C ≤ T_a ≤ +70 °C)

Table 53: Input Parameters

	U _i	I _i	P _i	C _i	L _i
SuperModule	30 V	300 mA	1.0 W	30 nF	0
3051S...A; 3051SF...A; 3051SAL...C	30 V	300 mA	1.0 W	12 nF	0
3051S...F; 3051SF...F	30 V	300 mA	1.3 W	0	0
3051S ...A...M7, M8, or M9; 3051SF ...A...M7, M8, or M9; 3051SAL...C... M7, M8, or M9	30 V	300 mA	1.0 W	12 nF	60 μH
3051SAL or 3051SAM	30 V	300 mA	1.0 W	12 nF	33 μH
3051SAL...M7, M8, or M9 3051SAM...M7, M8, or M9	30 V	300 mA	1.0 W	12 nF	93 μH
RTD Option for 3051SF	5 V	500 mA	0.63 W	N/A	N/A

Special Conditions for Safe Use (X):

1. The Model 3051S Transmitters fitted with transient protection are not capable of withstanding the 500V test as defined in Clause 6.3.13 f EN 60079-11:2012. This must be taken into account during installation.

- The terminal pins of the Model 3051S SuperModule must be provided with a degree of protection of at least IP20 in accordance with IEC/EN 60529.
- The Model 3051S enclosure may be made of aluminum alloy and given a protective polyurethane paint finish; however, care should be taken to protect it from impact or abrasion if located in a zone 0 area.

IA ATEX FISCO

Certificate BAS01ATEX1303X

Standards EN 60079-0: 2012+A11:2013, EN 60079-11: 2012

Markings  II 1 G Ex ia IIC T4 Ga, T4(-60 °C ≤ T_a ≤ +70 °C)

Table 54: Input Parameters

Parameter	FISCO
Voltage U _i	17.5 V
Current I _i	380 mA
Power P _i	5.32 W
Capacitance C _i	0
Inductance L _i	0

Special Conditions for Safe Use (X):

- The Model 3051S Transmitters fitted with transient protection are not capable of withstanding the 500 V test as defined in Clause 6.3.13 of EN 60079-11:2012. This must be taken into account during installation.
- The terminal pins of the Model 3051S SuperModule must be provided with a degree of protection of at least IP20 in accordance with IEC/EN 60529.
- The Model 3051S enclosure may be made of aluminum alloy and given a protective polyurethane paint finish; however, care should be taken to protect it from impact or abrasion if located in a zone 0 area.

ND ATEX Dust

Certificate BAS01ATEX1374X

Standards EN 60079-0: 2012+A11:2013, EN 60079-31: 2009

Markings  II 1 D Ex ta IIIC T105 °C T₅₀₀ 95 °C Da, (-20 °C ≤ T_a ≤ +85 °C), V_{max} = 42.4 V

Special Conditions for Safe Use (X):

- Cable entries must be used which maintain the ingress protection of the enclosure to at least IP66.
- Unused cable entries must be filled with suitable blanking plugs which maintain the ingress protection of the enclosure to at least IP66.
- Cable entries and blanking plugs must be suitable for the ambient temperature range of the apparatus and capable of withstanding a 7J impact test.
- The SuperModule(s) must be securely screwed in place to maintain the ingress protection of the enclosure(s).

N1 ATEX Type n

Certificate BAS01ATEX3304X

Standards EN 60079-0: 2012+A11:2013, EN 60079-15: 2010

Markings  II 3 G Ex nA IIC T5 Gc, (-40 °C ≤ T_a ≤ +85 °C), V_{max} = 45 V

Special Condition for Safe Use (X):

1. The equipment is not capable of withstanding the 500 V insulation test required by clause 6.5 of EN 60079-15:2010. This must be taken into account when installing the equipment.

Note

RTD Assembly is not included with the 3051Sfx Type n Approval.

International

E7 IECEx Flameproof and Dust

Certificate IECEx KEM 08.0010X (Flameproof)

Standards IEC 60079-0:2011, IEC 60079-1:2014, IEC 60079-26:2014

Markings Ex db IIC T6...T4 Ga/Gb, T6(-60 °C ≤ T_a ≤ +70 °C), T5/T4(-60 °C ≤ T_a ≤ +80 °C)

Table 55: Process Temperature

Temperature class	Process temperature
T6	-60 °C to +70 °C
T5	-60 °C to +80 °C
T4	-60 °C to +120 °C

Special Conditions for Safe Use (X):

1. This device contains a thin wall diaphragm less than 1 mm thickness that forms a boundary between EPL Ga (process connection) and EPL Gb (all other parts of the equipment). The model code and datasheet are to be consulted for details of the diaphragm material. Installation, maintenance and use shall take into account the environmental conditions to which the diaphragm will be subjected. The manufacturer's instructions for installation and maintenance shall be followed in detail to assure safety during its expected lifetime.
2. Flameproof joints are not intended for repair.
3. Non-standard paint options may cause risk from electrostatic discharge. Avoid installations that could cause electrostatic buildup on painted surfaces, and only clean the painted surfaces with a damp cloth. If paint is ordered through a special option code, contact the manufacturer for more information.
4. Appropriate cable, glands and plugs need to be suitable for a temperature of 5 °C greater than maximum specified temperature for location where installed.

Certificate IECEx BAS 09.0014X (Dust)

Standards IEC 60079-0:2011, IEC 60079-31:2008

Markings Ex ta IIIC T105 °C T50095 °C Da, (-20 °C ≤ T_a ≤ +85 °C), V_{max} = 42.4 V

Special Conditions for Safe Use (X):

1. Cable entries must be used which maintain the ingress protection of the enclosure to at least IP66.
2. Unused cable entries must be filled with suitable blanking plugs which maintain the ingress protection of the enclosure to at least IP66.
3. Cable entries and blanking plugs must be suitable for the ambient temperature range of the apparatus and capable of withstanding a 7J impact test.
4. The 3051S- SuperModule must be securely screwed in place to maintain the ingress protection of the enclosure.

I7 IECEx Intrinsic Safety

Certificate	IECEX BAS 04.0017X
Standards	IEC 60079-0: 2011, IEC 60079-11: 2011
Markings	Ex ia IIC T4 Ga, T4(-60 °C ≤ T _a ≤ +70 °C)

Table 56: Input Parameters

	U _i	I _i	P _i	C _i	L _i
SuperModule	30 V	300 mA	1.0 W	30 nF	0
3051S...A; 3051SF...A; 3051SAL...C	30 V	300 mA	1.0 W	12 nF	0
3051S...F; 3051SF...F	30 V	300 mA	1.3 W	0	0
3051S ...A...M7, M8, or M9; 3051SF ...A...M7, M8, or M9; 3051SAL...C... M7, M8, or M9	30 V	300 mA	1.0 W	12 nF	60 μH
3051SAL or 3051SAM	30 V	300 mA	1.0 W	12 nF	33 μH
3051SAL...M7, M8, or M9 3051SAM...M7, M8, or M9	30 V	300 mA	1.0 W	12 nF	93 μH
RTD Option for 3051SF	5 V	500 mA	0.63 W	N/A	N/A

Special Conditions for Safe Use (X):

1. The Model 3051S Transmitters fitted with transient protection are not capable of withstanding the 500 V test as defined in Clause 6.3.13 of EN 60079-11:2012. This must be taken into account during installation.
2. The terminal pins of the Model 3051S SuperModule must be provided with a degree of protection of at least IP20 in accordance with IEC/EN 60529.
3. The Model 3051S enclosure may be made of aluminum alloy and given a protective polyurethane paint finish; however, care should be taken to protect it from impact or abrasion if located in a zone 0 area.

I7 IECEx Intrinsic Safety - Group I - Mining (I7 with Special A0259)

Certificate	IECEX TSA 14.0019X
Standards	IEC 60079-0: 2011, IEC 60079-11: 2011
Markings	Ex ia I Ma (-60 °C ≤ T _a ≤ +70 °C)

Table 57: Input Parameters

	U _i	I _i	P _i	C _i	L _i
SuperModule	30 V	300 mA	1.0 W	30 nF	0
3051S...A; 3051SF...A; 3051SAL...C	30 V	300 mA	1.0 W	12 nF	0

Table 57: Input Parameters (continued)

	U_i	I_i	P_i	C_i	L_i
3051S...F; 3051SF...F	30 V	300 mA	1.3 W	0	0
3051S ...A...M7, M8, or M9; 3051SF ...A...M7, M8, or M9; 3051SAL...C... M7, M8, or M9	30 V	300 mA	1.0 W	12 nF	60 μ H
3051SAL or 3051SAM	30 V	300 mA	1.0 W	12 nF	33 μ H
3051SAL...M7, M8, or M9 3051SAM...M7, M8, or M9	30 V	300 mA	1.0 W	12 nF	93 μ H
RTD Option for 3051SF	5 V	500 mA	0.63 W	N/A	N/A

Special Conditions for Safe Use (X):

1. If the apparatus is fitted with optional 90 V transient suppressor, it is not capable of withstanding the 500 V insulation test required by Clause 6.3.13 of IEC60079-11. This must be taken into account when installing the apparatus.
2. It is a condition of safe use that the above input parameters shall be taken into account during installation.
3. It is a condition of manufacture that only the apparatus fitted with housing, covers and sensor module housing made out of stainless steel are used in Group I applications.

IG IECEX FISCO

Certificate	IECEX BAS 04.0017X
Standards	IEC 60079-0: 2011, IEC 60079-11: 2011
Markings	Ex ia IIC T4 Ga, T4(-60 °C ≤ T _a ≤ +70 °C)

Table 58: Input Parameters

Parameter	FISCO
Voltage U_i	17.5 V
Current I_i	380 mA
Power P_i	5.32 W
Capacitance C_i	0
Inductance L_i	0

Special Conditions for Safe Use (X):

1. The Model 3051S Transmitters fitted with transient protection are not capable of withstanding the 500 V test as defined in Clause 6.3.13 of EN 60079-11:2012. This must be taken into account during installation.
2. The terminal pins of the Model 3051S SuperModule must be provided with a degree of protection of at least IP20 in accordance with IEC/EN 60529.
3. The Model 3051S enclosure may be made of aluminum alloy and given a protective polyurethane paint finish; however, care should be taken to protect it from impact or abrasion if located in a zone 0 area.

IG IECEX Intrinsic Safety - Group I - Mining (IG with Special A0259)

Certificate	IECEX TSA 04.0019X
Standards	IEC 60079-0: 2011, IEC 60079-11: 2011

Markings FISCO FIELD DEVICE Ex ia I Ma , ($-60\text{ °C} \leq T_a \leq +70\text{ °C}$)

Table 59: Input Parameters

Parameter	FISCO
Voltage U_i	17.5 V
Current I_i	380 mA
Power P_i	5.32 W
Capacitance C_i	0
Inductance L_i	0

Special Conditions for Safe Use (X):

1. If the apparatus is fitted with optional 90 V transient suppressor, it is not capable of withstanding the 500 V insulation test required by Clause 6.3.13 of IEC60079-11. This must be taken into account when installing the apparatus.
2. It is a condition of safe use that the above input parameters shall be taken into account during installation.
3. It is a condition of manufacture that only the apparatus fitted with housing, covers and sensor module housing made out of stainless steel are used in Group I applications.

N7 IECEx Type n

Certificate IECEx BAS 04.0018X
Standards IEC 60079-0: 2011, IEC 60079-15: 2010
Markings Ex nA IIC T5 Gc, ($-40\text{ °C} \leq T_a \leq +85\text{ °C}$)

Special Condition for Safe Use (X):

1. The equipment is not capable of withstanding the 500 V insulation test required by clause 6.5 of EN 60079-15:2010. This must be taken into account when installing the equipment.

Brazil

E2 INMETRO Flameproof

Certificate UL-BR15.0393X
Standards ABNT NBR IEC 60079-0:2008 + Corrigendum 1:2011, ABNT NBR IEC 60079-1:2009 + Corrigendum 1:2011, ABNT NBR IEC 60079-26:2008 + Corrigendum 1: 2008
Markings Ex db IIC T* Ga/Gb, T6($-60\text{ °C} \leq T_a \leq +70\text{ °C}$), T5/T4($-60\text{ °C} \leq T_a \leq +80\text{ °C}$), IP66

Special Conditions for Safe Use (X):

1. The device contains a thin wall diaphragm less than 1mm thick that forms a boundary between zone 0 (process connection) and zone 1 (all other parts of the equipment). The model code and datasheet are to be consulted for details of the diaphragm material. Installation, maintenance, and use shall take into account the environmental conditions to which the diaphragm will be subjected. The manufacturer's instructions for maintenance shall be followed in detail to assure safety during its expected lifetime.
2. Flameproof joints are not intended for repair.

- Non-standard paint options may cause risk from electrostatic discharge. Avoid installations that could cause electrostatic buildup on painted surfaces, and only clean the painted surfaces with a damp cloth. If paint is ordered through a special option code, contact the manufacturer for more information.

I2/IB INMETRO Intrinsic Safety/FISCO

Certificate	UL-BR 15.0392X
Standards	ABNT NBR IEC 60079-0:2013, ABNT NBR IEC 60079-11:2013
Markings	Ex ia IIC T4 Ga (-60 °C ≤ T _a ≤ +70 °C), IP66

Special Conditions for Safe Use (X):

- The surface resistivity of the antenna is greater than 1 GΩ. To avoid electrostatic charge buildup, it must not be rubbed or cleaned with solvents or a dry cloth.
- The Model 701PBKKF Power Module may be replaced in a hazardous area. The Power Module has a surface resistivity greater than 1 GΩ and must be properly installed in the wireless device enclosure. Care must be taken during transportation to and from the point of installation to prevent electrostatic charge buildup.
- The 3051S enclosure may be made of aluminium alloy and given a protective polyurethane paint finish; however, care should be taken to protect it from impact or abrasion if located in areas that requires EPL Ga.

Table 60: Input Parameters

	U _i	I _i	P _i	C _i	L _i
SuperModule	30 V	300 mA	1.0 W	30 nF	0
3051S...A; 3051SF...A; 3051SAL...C	30 V	300 mA	1.0 W	12 nF	0
3051S...F; 3051SF...F	30 V	300 mA	1.3 W	0	0
3051S...F...IB; 3051SF...F...IB	17.5 V	380mA	5.32W	0	0
3051S ...A...M7, M8, or M9; 3051SF ...A...M7, M8, or M9; 3051SAL...C... M7, M8, or M9	30 V	300 mA	1.0 W	12 nF	60 μH
3051SAL or 3051SAM	30 V	300 mA	1.0 W	12 nF	33 μH
3051SAL... M7, M8, or M9 3051SAM... M7, M8, or M9	30 V	300 mA	1.0 W	12 nF	93 μH
RTD Option for 3051SF	5 V	500 mA	0.63 W	N/A	N/A

China

E3 China Flameproof and Dust Ignition-proof

Certificate	3051S: GYJ16.1249X 3051SFx: GYJ16.1466X 3051S-ERS: GJY15.1406X
Standards	3051S: GB3836.1-2010, GB3836.2-2010, GB3836.20-2010, GB12476.1-2013, GB12476.5-2013 3051SFx: GB3836.1-2010, GB3836.2-2010, GB3836.20-2010, GB12476.1-2013, GB 12476.5-2013 3051S-ERS: GB3836.1-2010, GB3836.2-2010, GB3836.20-2010

Markings 3051S: Ex d IIC T6...T4; Ex tD A20 T105 °C T50095 °C; IP66
 3051SFx: Ex d IIC T5/T6 Ga/Gb; DIP A20 TA105 °C; IP66
 3051S-ERS: Ex d IIC T4~T6 Ga/Gb

Special Conditions for Safe Use (X):

1. Only the pressure transmitters, consisting of 3051SC Series, 3051ST Series, 3051SL Series and 300S Series, are certified.
2. Flameproof joints are not intended for repair.
3. The ambient temperature range for the 3051S and 3051SFx in a dust environment is $-20\text{ °C} \leq T_a \leq 85\text{ °C}$.
4. The relation between temperature class and maximum temperature of process medium is as follows:

Temperature class	Ambient temperature (°C)	Process temperature (°C)
T6	$-60\text{ °C} \leq T_a \leq +70\text{ °C}$	$-60\text{ °C} \leq T_a \leq +70\text{ °C}$
T5	$-60\text{ °C} \leq T_a \leq +80\text{ °C}$	$-60\text{ °C} \leq T_a \leq +80\text{ °C}$
T4	$-60\text{ °C} \leq T_a \leq +80\text{ °C}$	$-60\text{ °C} \leq T_a \leq +120\text{ °C}$

5. The earth connection facility in the enclosure should be connected reliably.
6. During installation, use and maintenance of transmitter, observe the warning "Don't open the cover when the circuit is alive."
7. During installation, there should be no mixture harm to flameproof housing.
8. Cable entry, certified by NEPSI with type of protection Ex d IIC in accordance with GB3836.1-2000 and GB3836.2-2000, should be applied when installation in hazardous location. 5 full threads should be in engagement when the cable entry is assembled onto the transmitter. When pressure transmitter is used in the presence of combustible dust, the ingress of protection of the cable entry should be IP66.
9. The diameter of cable should observe the instruction manual of cable entry. The compressing nut should be fastened. The aging of seal ring should be changed in time.
10. Maintenance should be done in non-hazardous location.
11. End users are not permitted to change any components inside.
12. When installation, use and maintenance of transmitter, observe following standards:
 - GB3836.13-2013 "Electrical apparatus for explosive gas atmospheres Part 13: Repair and overhaul for apparatus used in explosive gas atmospheres"
 - GB3836.15-2000 "Electrical apparatus for explosive gas atmospheres Part 15: Electrical installations in hazardous area (other than mines)"
 - GB3836.16-2006 "Electrical apparatus for explosive gas atmospheres Part 16: Inspection and maintenance of electrical installation (other than mines)"
 - GB50257-2014 "Code for construction and acceptance of electric device for explosion atmospheres and fire hazard electrical equipment installation engineering"
 - GB15577-2007/1995 "Safe regulation for explosive dust atmospheres"
 - GB12476.2-2010 "Electrical apparatus for use in the presence of combustible dust - Part 1-2: Electrical apparatus protected by enclosures and surface temperature limitation - Selection, installation and maintenance"

I3 China Intrinsic Safety

Certificate 3051S: GYJ16.1250X [Mfg USA, China, Singapore]
 3051SFx: GYJ16.1465X [Mfg USA, China, Singapore]
 3051S-ERS: GYJ16.1248X [Mfg USA, China, Singapore]

Standards 3051S: GB3836.1-2010, GB3836.4-2010, GB3836.20-2010
 3051SFx: GB3836.1/4-2010, GB3836.20-2010, GB12476.1-2013, GB12476.5-2013

3051S-ERS: GB3836.1-2010, GB3836.4-2010, GB3836.20-2010

Markings 3051S, 3051SFx: Ex ia IIC T4 Ga
 3051S-ERS: Ex ia IIC T4

Special Conditions for Safe Use (X):

1. Symbol "X" is used to denote specific conditions of use: For output code A and F: This apparatus is not capable of withstanding the 500V r.m.s. insulation test required by Clause 6.4.12 of GB3836.4-2000.
2. The ambient temperature range is:

Output code	Ambient temperature
A	-50 °C ≤ T _a ≤ +70 °C
F	-50 °C ≤ T _a ≤ +60 °C

3. Intrinsically safe parameters:

Output code	Housing code	Display code	Maximum input voltage: U _i (V)	Maximum input current: I _i (mA)	Maximum input power: P _i (W)	Maximum internal parameter: C _i (nF)	Maximum internal parameter: L _i (uH)
A	≠00	/	30	300	1	38	0
A	≠00	/	30	300	1	11.4	2.4
A	≠00	M7/M8/M9	30	300	1	0	58.2
F	≠00	/	30	300	1.3	0	0
F	≠00	/	17.5	500	5.5	0	0
FISCO							

4. The product should be used with Ex-certified associated apparatus to establish explosion protection system that can be used in explosive gas atmospheres. Wiring and terminals should comply with the instruction manual of the product and associated apparatus.
5. The cable between this product and associated apparatus should be shielded cables (the cables must have insulated shield). The shield has to be grounded reliably in non-hazardous area.
6. The product complies to the requirements for FISCO field devices specified in IEC60079-27:2008. For the connection of an intrinsically safe circuit in accordance FISCO model, FISCO parameters of this product are as above.
7. End users are not permitted to change any components inside, but to settle the problem in conjunction with manufacturer to avoid damage to the product.
8. When installation, use and maintenance of this product, observe the following standards:
 - GB3836.13-2013 "Electrical apparatus for explosive gas atmospheres Part 13: Repair and overhaul for apparatus used in explosive gas atmospheres"
 - GB3836.15-2000 "Electrical apparatus for explosive gas atmospheres Part 15: Electrical installations in hazardous area (other than mines)"
 - GB3836.16-2006 "Electrical apparatus for explosive gas atmospheres Part 16: Inspection and maintenance of electrical installation (other than mines)"
 - GB3836.18-2010 "Intrinsically Safe System"
 - GB50257-20141996 "Code for construction and acceptance of electric device for explosion atmospheres and fire hazard electrical equipment installation engineering"

N3 China Type n

Certificate 3051S: GYJ17.1354X

3051SFX: GYJ17.1355X

Markings

Ex nA IIC T5 Gc

Special Condition for Safe Use (X):

1. When transient protection board is chosen (Option Code T1), this apparatus is not capable of withstanding the 500V r.m.s insulation test, this must be taken into account when installing the component.

EAC - Belarus, Kazakhstan, Russia**EM Technical Regulation Customs Union (EAC) Flameproof and Dust Ignition-proof****Certificate** RU C-US.AA87.B.00378**Markings**

Ga/Gb Ex d IIC T6...T4 X

Ex tb IIIC T105 °C T₅₀₀95 °C Db XEx ta IIIC T105 °C T₅₀₀95 °C Da X**IM Technical Regulation Customs Union (EAC) Intrinsic Safety****Certificate** RU C-US.AA87.B.00094**Markings**

0Ex ia IIC T4 Ga X

Japan**E4 Japan Flameproof****Certificate** TC15682, TC15683, TC15684, TC15685, TC15686, TC15687, TC15688, TC15689, TC15690, TC17099, TC17100, TC17101, TC17102, TC18876

3051ERS: TC20215, TC20216, TC20217, TC20218, TC20219, TC20220, TC20221

Markings Ex d IIC T6**Republic of Korea****EP Republic of Korea Flameproof****Certificate** 12-KB4BO-0180X [Mfg USA], 11-KB4BO-0068X [Mfg Singapore]**Markings**

Ex d IIC T6...T4

IP Republic of Korea Intrinsic Safety**Certificate** 12-KB4BO-0202X [HART - Mfg USA], 12-KB4BO-0204X [Fieldbus - Mfg USA], 12-KB4BO-0203X [HART - Mfg Singapore], 13-KB4BO-0296X [Fieldbus - Mfg Singapore]

Markings Ex ia IIC T4

Combinations

K1	Combination of E1, I1, N1, and ND
K2	Combination of E2 and I2
K5	Combination of E5 and I5
K6	Combination of E6 and I6
K7	Combination of E7, I7, and N7
KA	Combination of E1, I1, E6, and I6
KB	Combination of E5, I5, E6, and I6
KC	Combination of E1, I1, E5, and I5
KD	Combination of E1, I1, E5, I5, E6, and I6
KG	Combination of IA, IE, IF, and IG
KM	Combination of EM and IM
KP	Combination of EP and IP

Additional Certifications

SBS American Bureau of Shipping (ABS) Type Approval

Certificate 00-HS145383-6-PDA

Intended Use Measure gauge or absolute pressure of liquid, gas or vapor applications on ABS classed vessels, marine, and offshore installations.

SBV Bureau Veritas (BV) Type Approval

Certificate 31910 BV

Requirements Bureau Veritas Rules for the Classification of Steel Ships

Application Class Notations: AUT-UMS, AUT-CCS, AUT-PORT and AUT-IMS.

SDN Det Norske Veritas (DNV) Type Approval

Certificate A-14186

Intended Use Det Norske Veritas' Rules for Classification of Ships, High Speed & Light Craft, and Det Norske Veritas' Offshore Standards.

Application

Location classes	
Type	3051S

Temperature	D
Humidity	B
Vibration	A
EMC	A
Enclosure	D/IP66/IP68

SLL Lloyds Register (LR) Type Approval

Certificate	11/60002
Application	Environmental categories ENV1, ENV2, ENV3, and ENV5

D3 Custody Transfer - Measurement Canada Accuracy Approval [3051S Only]

Certificate	AG-0501, AV-2380C
--------------------	-------------------

Rosemount 3051S and 3051SMV Wireless

Rev 2.4

European Directive Information

A copy of the EC Declaration of Conformity can be found at the end of the Quick Start Guide. The most recent revision of the EC Declaration of Conformity can be found at Emerson.com/Rosemount.

Telecommunication Compliance

All wireless devices require certification to ensure that they adhere to regulations regarding the use of the RF spectrum. Nearly every country requires this type of product certification.

Emerson is working with governmental agencies around the world to supply fully compliant products and remove the risk of violating country directives or laws governing wireless device usage.

FCC and IC

This device complies with Part 15 of the FCC Rules. Operation is subject to the following conditions: This device may not cause harmful interference. This device must accept any interference received, including interference that may cause undesired operation. This device must be installed to ensure a minimum antenna separation distance of 20 cm from all persons.

Ordinary Location Certification

As standard, the transmitter has been examined and tested to determine that the design meets the basic electrical, mechanical, and fire protection requirements by a nationally recognized test laboratory (NRTL) as accredited by the Federal Occupational Safety and Health Administration (OSHA).

Installing Equipment in North America

The US National Electrical Code (NEC) and the Canadian Electrical Code (CEC) permit the use of Division marked equipment in Zones and Zone marked equipment in Divisions. The markings must be suitable for the area classification, gas, and temperature class. This information is clearly defined in the respective codes.

USA

I5 USA Intrinsically Safe (IS), Nonincendive (NI), and Dust-Ignitionproof (DIP)

Certificate FM18US0009X

Standards FM Class 3600 – 2011, FM Class 3610 – 2010, FM Class 3611 – 2004, FM Class 3810 – 2005, NEMA[®] 250 – 2003

Markings IS CL I, DIV 1, GP A, B, C, D; CL II, DIV 1, GP E, F, G; CL III T4; CL 1, Zone 0 AEx ia IIC T4; NI CL 1, DIV 2, GP A, B, C, D T4; DIP CL II, DIV 1, GP E, F, G; CL III, T5; T4(-50 °C ≤ T_a ≤ +70 °C)/ T5(-50 °C ≤ T_a ≤ +85 °C); when connected per Rosemount drawing 03151-1000; Type 4X

Special Conditions for Safe Use (X):

1. The Rosemount 3051S and SMV Wireless Transmitters shall only be used with the 701PBKKF Rosemount SmartPower Battery Pack (P/N 00753-9220-0001), Computational Systems Inc Battery Pack (P/N MHM-89004) or alternatively the Perpetuum Intelligent Power Module Vibration Harvester (P/N IPM71008).
2. The transmitter may contain more than 10% aluminum and is considered a potential risk of ignition by impact or friction. Care must be taken into account during installation and use to prevent impact and friction.
3. The surface resistivity of the antenna is greater than 1 GΩ. To avoid electrostatic charge build-up, it must not be rubbed or cleaned with solvents or a dry cloth.

Canada

I6 Canada Intrinsically Safe

Certificate CSA 1143113

Standards CAN/CSA C22.2 No. 0-10, CSA Std C22.2 No. 30-M1986, CAN/CSA C22.2 No. 94-M91, CSA Std C22.2 No. 142-M1987, CSA Std C22.2 No. 157-92, ANSI/ISA 12.27.01-2003, CSA Std C22.2 No. 60529:05

Markings Intrinsically Safe Class I, Division 1; suitable for Class 1, Zone 0, IIC, T3C; when connected per Rosemount drawing 03151-1010; Type 4X

Europe

I1 ATEX Intrinsic Safety

Certificate Baseefa13ATEX0127X

Standards EN 60079-0: 2012, EN 60079-11: 2012

Markings  II 1 G Ex ia IIC T4 Ga, T4(-60 °C ≤ T_a ≤ +70 °C)

Special Conditions for Safe Use (X):

1. The Rosemount 3051S Wireless and Rosemount 3051SMV Wireless enclosure may be made of aluminum alloy and given a protective polyurethane paint finish; however, care should be taken to protect it from impact or abrasion if located in a zone 0 area.
2. The surface resistivity of the antenna is greater than 1 GΩ. To avoid electrostatic charge build-up, it must not be rubbed or cleaned with solvents or dry cloth.

International

I7 IECEx Intrinsic Safety

Certificate	IECEx BAS 13.0068X
Standards	IEC 60079-0:2011, IEC 60079-11:2011
Markings	Ex ia IIC T4 Ga, T4(-60 °C ≤ T _a ≤ +70 °C)

Special Conditions for Safe Use (X):

1. The Rosemount 3051S Wireless and Rosemount 3051SMV Wireless enclosure may be made of aluminum alloy and given a protective polyurethane paint finish; however, care should be taken to protect it from impact or abrasion if located in a zone 0 area.
2. The surface resistivity of the antenna is greater than 1GΩ . To avoid electrostatic charge build-up, it must not be rubbed or cleaned with solvents or dry cloth.

Brazil

I2 INMETRO Intrinsic Safety

Certificate	UL-BR 14.0760X
Standards	ABNT NBR IEC60079-0:2008 + Errata 1:2011, ABNT NBR IEC60079-11: 2009
Markings	Ex ia IIC T4 Ga, T4(-60 °C ≤ T _a ≤ +70 °C)

Special Condition for Safe Use (X):

1. See certificate.

China

I3 China Intrinsic Safety

Certificate	3051S Wireless: GYJ161250X 3051SFX: GYJ16.1465X [flow meters]
Standards	GB3836.1-2010, GB3836.4-2010, GB3836.20-2010
Markings	Ex ia IIC T4 Ga, T4(-60 ~ 70 °C)

Special Condition for Safe Use (X):

1. See appropriate certificate.

Note

Not currently available on the Rosemount 3051S MultiVariable Wireless Transmitter.

Japan

I4 TIIS Intrinsically Safe

Certificate	TC18649, TC18650, TC18657
Markings	Ex ia IIC T4, T4(-20 ~ 60 °C)

Note

Not currently available on the Rosemount 3051S MultiVariable Wireless Transmitter.

EAC - Belarus, Kazakhstan, Russia

IM EAC Intrinsic Safety

Certificate	TC RU C-US.AA87.B.00378
Markings	0Ex ia IIC T4 Ga X (-60 °C ≤ T _a ≤ +70 °C)

Special Condition for Safe Use (X):

1. See certificate for special conditions.
-

Note

Not currently available on the Rosemount 3051S MultiVariable Wireless Transmitter.

Republic of Korea

IP Korea Intrinsic Safety

Certificates	12-KB4BO-0202X, 12-KB4BO-0203X
Markings	Ex ia IIC T4, (-60 °C ≤ T _a ≤ +70 °C)

Note

Not currently available on the Rosemount 3051S MultiVariable Wireless Transmitter.

Special Condition for Safe Use (X):

1. See certificate for special conditions.

Combinations

KQ	Combination of I1, I5, and I6
----	-------------------------------

Rosemount 3051SMV/3051SFx

Rev 1.23

European Directive Information

A copy of the EU Declaration of Conformity can be found at the end of the Quick Start Guide. The most recent revision of the EU Declaration of Conformity can be found at EmersonProcess.com/Rosemount.

Ordinary Location Certification

As standard, the transmitter has been examined and tested to determine that the design meets the basic electrical, mechanical, and fire protection requirements by a nationally recognized test laboratory (NRTL) as accredited by the Federal Occupational Safety and Health Administration (OSHA).

Installing Equipment in North America

The US National Electrical Code (NEC) and the Canadian Electrical Code (CEC) permit the use of Division marked equipment in Zones and Zone marked equipment in Divisions. The markings must be suitable for the area classification, gas, and temperature class. This information is clearly defined in the respective codes.

USA

E5 US Explosionproof (XP) and Dust-Ignitionproof (DIP)

Certificate FM16US0089X

Standards FM Class 3600 – 2011, FM Class 3615 – 2006, FM Class 3616 – 2011, 3810 – 2005, ANSI/NEMA 250 – 2003

Markings XP CL I, DIV 1, GP B, C, D; T5; DIP CL II, DIV 1, GP E, F, G; CL III; T5(–50 °C ≤ T_a ≤ +85 °C); Factory Sealed; Type 4X

I5 US Intrinsically Safe (IS) and Nonincendive (NI)

Certificate FM16US0233

Standards FM Class 3600 – 2011, FM Class 3610 – 2007, FM Class 3611 – 2004, FM Class 3810 – 2005, NEMA 250 – 1991

Markings IS CL I, DIV 1, GP A, B, C, D; CL II, DIV 1, GP E, F, G; Class III; Class 1, Zone 0 AEx ia IIC T4; NI CL 1, DIV 2, GP A, B, C, D; T4(–50 °C ≤ T_a ≤ +70 °C) when connected per Rosemount drawing 03151-1206; Type 4X

Note

Transmitters marked with NI CL 1, DIV 2 can be installed in Division 2 locations using general Division 2 wiring methods or Nonincendive Field Wiring (NIFW). See Drawing 03151-1206.

IE US FISCO Intrinsically Safe

Certificate FM16US0233

Standards FM Class 3600 – 2011, FM Class 3610 – 2010, FM Class 3611 – 2004, FM Class 3616 – 2006, FM Class 3810 – 2005, NEMA 250 – 1991

Markings IS CL I, DIV 1, GP A, B, C, D;

Standards T4(–50 °C ≤ T_a ≤ +70 °C); when connected per Rosemount drawing 03151-1006; Type 4X

Canada

E6 Canada Explosionproof, Dust Ignition-proof, Division 2

Certificate 1143113

Standards CAN/CSA C22.2 No. 0-10, CSA Std C22.2 No. 25-1966, CSA Std C22.2 No. 30-M1986, CSA C22.2 No. 94.2-07, CSA Std C22.2 No. 213-M1987, CAN/CSA C22.2 60079-11:14, CAN/CSA-C22.2 No. 61010-1-12, ANSI/ISA 12.27.01-2003, CSA Std C22.2 No. 60529:05 (R2010)

Markings Explosionproof Class I, Division 1, Groups B, C, D; Dust-Ignitionproof Class II, Division 1, Groups E, F, G; Class III; suitable for Class I, Division 2, Groups A, B, C, D; Type 4X

I6 Canada Intrinsically Safe

Certificate 1143113

Standards CAN/CSA C22.2 No. 0-10, CSA Std C22.2 No. 25-1966, CSA Std C22.2 No. 30-M1986, CSA C22.2 No. 94.2-07, CSA Std C22.2 No. 213-M1987, CAN/CSA C22.2 60079-11:14, CAN/CSA-C22.2 No. 61010-1-12, ANSI/ISA 12.27.01-2003, CSA Std C22.2 No. 60529:05 (R2010)

Markings Intrinsically Safe Class I, Division 1; suitable for Class 1, Zone 0, IIC, T3C, Ta = 70 °C; when connected per Rosemount drawing 03151-1207; Type 4X

IF Canada FISCO Intrinsically Safe

Certificate 1143113

Standards CAN/CSA C22.2 No. 0-10, CSA Std C22.2 No. 25-1966, CSA Std C22.2 No. 30-M1986, CSA C22.2 No. 94.2-07, CSA Std C22.2 No. 213-M1987, CAN/CSA C22.2 60079-11:14, CAN/CSA-C22.2 No. 61010-1-12, ANSI/ISA 12.27.01-2003, CSA Std C22.2 No. 60529:05 (R2010)

Markings FISCO Intrinsically Safe Class I, Division 1; Groups A, B, C, D; suitable for Class I, Zone 0; T3C, Ta = 70 °C; when installed per Rosemount drawing 03151-1207; Type 4X

Europe

E1 ATEX Flameproof

Certificate KEMA 00ATEX2143X

Standards EN 60079-0:2012+A11:2013, EN 60079-1: 2014, EN 60079-26:2015

Markings  II 1/2 G Ex db IIC T6...T4 Ga/Gb, T6(-60 °C ≤ Ta ≤ +70 °C), T5/T4(-60 °C ≤ Ta ≤ +80 °C)

Temperature class	Process temperature
T6	-60 °C to +70 °C
T5	-60 °C to +80 °C
T4	-60 °C to +120 °C

Special Conditions for Safe Use (X):

1. This device contains a thin wall diaphragm less than 1 mm thickness that forms a boundary between Category 1 (process connection) and Category 2 (all other parts of the equipment). The model code and datasheet are to be consulted for details of the diaphragm material. Installation, maintenance and use shall take into account the environmental conditions to which the diaphragm will be subjected. The manufacturer's instructions for installation and maintenance shall be followed in detail to assure safety during its expected lifetime.
2. Flameproof joints are not intended for repair.

3. Non-standard paint options may cause risk from electrostatic discharge. Avoid installations that could cause electrostatic build-up on painted surfaces, and only clean the painted surfaces with a damp cloth. If paint is ordered through a special option code, contact the manufacturer for more information.
4. Appropriate cable, glands and plugs need to be suitable for a temperature of 5 °C greater than maximum specified temperature for location where installed.

I1 ATEX Intrinsic Safety

Certificate Baseefa08ATEX0064X

Standards EN 60079-0:2012, EN 60079-11:2012

Markings  II 1 G Ex ia IIC T4 Ga, T4(-60 °C ≤ T_a ≤ +70 °C)

Parameter	HART	FOUNDATION Fieldbus	SuperModule only	RTD (for 3051SFx)	
				HART	Fieldbus
Voltage U _i	30 V	30 V	7.14 V	30 V	30 V
Current I _i	300 mA	300 mA	300 mA	2.31 mA	18.24 mA
Power P _i	1 W	1.3 W	887 mW	17.32 mW	137 mW
Capacitance C _i	14.8 nF	0	0.11 μF	0	0.8 nF
Inductance L _i	0	0	0	0	1.33 mH

Special Conditions for Safe Use (X):

1. If the equipment is fitted with the optional 90 V transient suppressor, it is incapable of withstanding the 500 V isolation from earth test and this must be taken into account during installation.
2. The enclosure may be made of aluminum alloy and given a protective polyurethane paint finish; however, care should be taken to protect it from impact or abrasion if located in a Zone 0 environment.

IA ATEX FISCO

Certificate Baseefa08ATEX0064X

Standards EN 60079-0:2012, EN 60079-11:2012

Markings  II 1 G Ex ia IIC T4 Ga, T4(-60 °C ≤ T_a ≤ +70 °C)

Parameter	FISCO
Voltage U _i	17.5 V
Current I _i	380 mA
Power P _i	5.32 W
Capacitance C _i	0
Inductance L _i	0

ND ATEX Dust

Certificate BAS01ATEX1374X

Standards EN 60079-0:2012, EN 60079-31:2009

Markings 

II 1 D Ex ta IIIC T105 °C T₅₀₀ 95 °C Da, (-20 °C ≤ T_a ≤ +85 °C), V_{max} = 42.4 V

Special Conditions for Safe Use (X):

1. Cable entries must be used which maintain the ingress protection of the enclosure to at least IP66.
2. Unused cable entries must be filled with suitable blanking plugs which maintain the ingress protection of the enclosure to at least IP66.
3. Cable entries and blanking plugs must be suitable for the ambient temperature range of the apparatus and capable of withstanding a 7J impact test.
4. The SuperModule(s) must be securely screwed in place to maintain the ingress protection of the enclosure(s).

N1 ATEX Type n

Certificate Baseefa08ATEX0065X

Standards EN 60079-0:2012, EN 60079-15:2010

Markings 

II 3 G Ex nA IIC T4 Gc, (-40 °C ≤ T_a ≤ 70 °C), V_{max} = 45 V

Special Condition for Safe Use (X):

1. If fitted with a 90 V transient suppressor, the equipment is not capable of withstanding the 500 V electrical strength test as defined in Clause 6.5.1 of EN 60079-15:2010. This must be taken into account during installation.

International

E7 IECEx Flameproof and Dust

Certificate IECEx KEM 08.0010X (Flameproof)

Standards IEC 60079-0:2011, IEC 60079-1:2014, IEC 60079-26:2014

Markings Ex db IIC T6...T4 Ga/Gb, T6(-60 °C ≤ T_a ≤ +70 °C), T5/T4(-60 °C ≤ T_a ≤ +80 °C)

Temperature class	Process temperature
T6	-60 °C to +70 °C
T5	-60 °C to +80 °C
T4	-60 °C to +120 °C

Special Conditions for Safe Use (X):

1. This device contains a thin wall diaphragm less than 1 mm thickness that forms a boundary between EPL Ga (process connection) and EPL Gb (all other parts of the equipment). The model code and datasheet are to be consulted for details of the diaphragm material. Installation, maintenance and use shall take into account the environmental conditions to which the diaphragm will be subjected. The manufacturer's instructions for installation and maintenance shall be followed in detail to assure safety during its expected lifetime.
2. Flameproof joints are not intended for repair.
3. Non-standard paint options may cause risk from electrostatic discharge. Avoid installations that could cause electrostatic build-up on painted surfaces, and only clean the painted surfaces with a damp cloth. If paint is ordered through a special option code, contact the manufacturer for more information.

4. Appropriate cable, glands and plugs need to be suitable for a temperature of 5°C greater than maximum specified temperature for location where installed.

Certificate: IECEx BAS 09.0014X (Dust)

Standards: IEC 60079-0:2011, IEC 60079-31:2008

Markings: Ex ta IIC T105 °C T₅₀₀ 95 °C Da, (-20 °C ≤ T_a ≤ +85 °C), V_{max} = 42.4 V

Special Conditions for Safe Use (X):

1. Cable entries must be used which maintain the ingress protection of the enclosure to at least IP66.
2. Unused cable entries must be filled with suitable blanking plugs which maintain the ingress protection of the enclosure to at least IP66.
3. Cable entries and blanking plugs must be suitable for the ambient temperature range of the apparatus and capable of withstanding a 7J impact test.
4. The Rosemount 3051S - SuperModule must be securely screwed in place to maintain the ingress protection of the enclosure.

I7 IECEx Intrinsic Safety

Certificate IECEx BAS 08.0025X
Standards IEC 60079-0:2011, IEC 60079-11:2011
Markings Ex ia IIC T4 Ga, T4(-60 °C ≤ T_a ≤ +70 °C)

Parameter	HART	FOUNDATION Fieldbus	SuperModule only	RTD (for 3051SFx)	
				HART	Fieldbus
Voltage U _i	30 V	30 V	7.14 V	30 V	30 V
Current I _i	300 mA	300 mA	300 mA	2.31 mA	18.24 mA
Power P _i	1 W	1.3 W	887 mW	17.32 mW	137 mW
Capacitance C _i	14.8 nF	0	0.11 μF	0	0.8 nF
Inductance L _i	0	0	0	0	1.33 mH

Special Conditions for Safe Use (X):

1. If the equipment is fitted with the optional 90 V transient suppressor, it is incapable of withstanding the 500 V isolation from earth test and this must be taken into account during installation.
2. The enclosure may be made of aluminum alloy and given a protective polyurethane paint finish; however, care should be taken to protect it from impact or abrasion if located in a Zone 0 environment.

IG IECEx FISCO

Certificate IECEx BAS 08.0025X
Standards IEC 60079-0:2011, IEC 60079-11:2011
Markings Ex ia IIC T4 Ga, T4(-60 °C ≤ T_a ≤ +70 °C)

Parameter	FISCO
Voltage U _i	17.5 V
Current I _i	380 mA
Power P _i	5.32 W

Parameter	FISCO
Capacitance C_i	0
Inductance L_i	0

N7 IECEx Type n

Certificate	IECEx BAS 08.0026X
Standards	IEC 60079-0:2011, IEC 60079-15:2010
Markings	Ex nA IIC T5 Gc, ($-40\text{ °C} \leq T_a \leq 70\text{ °C}$)

Special Condition for Safe Use (X):

1. If fitted with a 90 V transient suppressor, the equipment is not capable of withstanding the 500 V electrical strength test as defined in Clause 6.5.1 of IEC 60079-15:2010. This must be taken into account during installation.

Brazil**E2 INMETRO Flameproof**

Certificate	UL-BR 15.0393X
Standards	ABNT NBR IEC 60079-0:2008 + Corrigendum 1:2011, ABNT NBR IEC 60079-1:2009 + Corrigendum 1:2011, ABNT NBR IEC 60079-26:2008 + Corrigendum 1: 2008
Markings	Ex db IIC T* Ga/Gb, T6 ($-60\text{ °C} \leq T_a \leq +70\text{ °C}$), T5/T4 ($-60\text{ °C} \leq T_a \leq +80\text{ °C}$), IP66

Special Conditions for Safe Use (X):

1. The device contains a thin wall diaphragm less than 1mm thick that forms a boundary between zone 0 (process connection) and zone 1 (all other parts of the equipment). The model code and datasheet are to be consulted for details of the diaphragm material. Installation, maintenance, and use shall take into account the environmental conditions to which the diaphragm will be subjected. The manufacturer's instructions for maintenance shall be followed in detail to assure safety during its expected lifetime.
2. Flameproof joints are not intended for repair.
3. Non-standard paint options may cause risk from electrostatic discharge. Avoid installations that could cause electrostatic build-up on painted surfaces, and only clean the painted surfaces with a damp cloth. If paint is ordered through a special option code, contact the manufacturer for more information.

I2 INMETRO Intrinsic Safety

Certificate	UL-BR 15.0357X
Standards	ABNT NBR IEC 60079-0:2008 + Addendum 1:2011, ABNT NBR IEC 60079-11:2009
Markings	Ex ia IIC T4 Ga ($-60\text{ °C} \leq T_a \leq +70\text{ °C}$)

Special Conditions for Safe Use (X):

1. If the equipment is fitted with the optional 90V transient suppressor, it is incapable of withstanding the 500V isolation from earth test and this must be taken into account during installation.
2. The enclosure may be made of aluminium alloy and given a protective polyurethane paint finish; however, care should be taken to protect it from impact or abrasion if located in a Zone 0 environment, areas requiring EPL Ga.

Parameter	HART		Fieldbus	
	Input	RTD	Input	RTD
Voltage U_i	30 V	30 V	30 V	30 V
Current I_i	300 mA	2.31 mA	300 mA	18.24 mA
Power P_i	1 W	17.32 mW	1.3 W	137 mW
Capacitance C_i	14.8 nF	0	0	0.8 nF
Inductance L_i	0	0	0	1.33 mH

I2/IB INMETRO Intrinsic Safety/FISCO

Certificate UL-BR 15.0392X

Standards ABNT NBR IEC 60079-0:2013, ABNT NBR IEC 60079-11:2013

Markings Ex ia IIC T4 Ga ($-60\text{ }^{\circ}\text{C} \leq T_a \leq +70\text{ }^{\circ}\text{C}$), IP66

Special Conditions for Safe Use (X):

1. The surface resistivity of the antenna is greater than 1 GΩ. To avoid electrostatic charge buildup, it must not be rubbed or cleaned with solvents or a dry cloth.
2. The Model 701PBKKF Power Module may be replaced in a hazardous area. The Power Module has a surface resistivity greater than 1 GΩ and must be properly installed in the wireless device enclosure. Care must be taken during transportation to and from the point of installation to prevent electrostatic charge buildup.
3. The 3051S enclosure may be made of aluminium alloy and given a protective polyurethane paint finish; however, care should be taken to protect it from impact or abrasion if located in areas that requires EPL Ga.

Table 61: Input Parameters

	U_i	I_i	P_i	C_i	L_i
SuperModule	30 V	300 mA	1.0 W	30 nF	0
3051S...A; 3051SF...A; 3051SAL...C	30 V	300 mA	1.0 W	12 nF	0
3051S...F; 3051SF...F	30 V	300 mA	1.3 W	0	0
3051S...F...IB; 3051SF...F...IB	17.5 V	380mA	5.32W	0	0
3051S ...A...M7, M8, or M9; 3051SF ...A...M7, M8, or M9; 3051SAL...C... M7, M8, or M9	30 V	300 mA	1.0 W	12 nF	60 μH
3051SAL or 3051SAM	30 V	300 mA	1.0 W	12 nF	33 μH
3051SAL... M7, M8, or M9 3051SAM... M7, M8, or M9	30 V	300 mA	1.0 W	12 nF	93 μH
RTD Option for 3051SF	5 V	500 mA	0.63 W	N/A	N/A

China

E3 China Flameproof and Dust Ignition-proof

Certificate 3051SMV: GYJ14.1039X [Mfg USA, China, Singapore]

3051SFx: GYJ11.1466X [Mfg USA, China, Singapore]

- Standards** 3051SMV: GB3836.1-2010, GB3836.2-2010, GB3836.20-2010
 3051SFx: GB3836.1-2010, GB3836.2-2010, GB3836.20-2010, GB12476.1-2013, GB12476.5-2013
- Markings** 3051SMV: Ex d IIC T6/T5 Ga/Gb
 3051SFx: Ex d IIC T4...T6 Ga/Gb; Ex tD A20 T_A 105 °C; IP66

Special Conditions for Safe Use (X):

1. Symbol “X” is used to denote specific conditions of use: For information on the dimensions of the flameproof joints the manufacturer shall be contacted.
2. The relationship between T code and ambient temperature range for the 3051SMV are as follows:

T code	Ambient temperature range
T6	-50 °C ~ +65 °C
T5	-50 °C ~ +80 °C

The relationship between T code and ambient temperature range for the 3051SFx are as follows:

T code	Ambient temperature range
T6	-60 °C ~ +70 °C
T4/T5	-60 °C ~ +80 °C

3. The earth connection facility in the enclosure should be connected reliably.
4. During installation, use and maintenance of the product in explosive atmosphere, observe the warning “Do not open cover when circuit is alive”. During installation, use, and maintenance in explosive dust atmosphere, observe the warning “Do not open when an explosive dust atmosphere is present”.
5. During installation there should be no mixture harmful to the housing.
6. During installation, use and maintenance in explosive dust atmosphere, product enclosure should be cleaned to avoid dust accumulation, but compressed air should not be used.
7. During installation in a hazardous location, cable glands and blanking plugs certified by state appointed inspection bodies with Ex d IIC Gb or Ex d IIC Gb DIP A20 [flow meters] IP66 type of protection should be used. Redundant cable entries should be blocked with blanking plugs.
8. End users are not permitted to change any components, but to contact the manufacturer to avoid damage to the product.
9. Maintenance should be done when no explosive gas and dust atmosphere is present.
10. During installation, use and maintenance of this product, observe following standards:
 GB3836.13-1997 “Electrical apparatus for explosive gas atmospheres Part 13: Repair and overhaul for apparatus used in explosive gas atmospheres”
 GB3836.15-2000 “Electrical apparatus for explosive gas atmospheres Part 15: Electrical installations in hazardous area (other than mines)”
 GB3836.16-2006 “Electrical apparatus for explosive gas atmospheres Part 16: Inspection and maintenance of electrical installation (other than mines)”
 GB50257-1996 “Code for construction and acceptance of electric device for explosion atmospheres and fire hazard electrical equipment installation engineering”
 GB15577-2007 “Safety regulations for dust explosion prevention and protection”
 GB12476.2-2010 “Electrical apparatus for use in the presence of combustible dust”

I3 China Intrinsic Safety

Certificate	3051SMV: GYJ14.1040X [Mfg USA, China, Singapore] 3051SFx: GYJ16.14 [Mfg USA, China, Singapore]
Standards	3051SMV: GB3836.1-2010, GB3836.4-2010, GB3836.20-2010 3051SFx: GB3836.1/4-2010, GB3836.20-2010, GB12476.1-2000
Markings	3051SMV: Ex ia IIC T4 Ga 3051SFx: Ex ia IIC T4 Ga, Ex tD A20 T _A 105 °C T ₅₀₀ 95 °C; IP66

Special Conditions for Safe Use (X):

1. The enclosure may contain light metal, attention should be taken to avoid ignition hazard due to impact or friction.
2. The apparatus is not capable of withstanding the 500V electrical strength test defined in Clause 6.3.12 of GB3836.4-2010.
3. Ambient temperature range: -60 °C ~ +70 °C
4. Intrinsically safe electric parameters:

Maximum input voltage: U_i (V)	Maximum input current: I_i (mA)	Maximum input power: P_i (W)	Maximum internal parameters:	
			C_i (nF)	L_i (μH)
30	300	1.0	14.8	0

	Maximum output voltage: U_i (V)	Maximum output current: I_i (mA)	Maximum output power: P_i (W)	Maximum external parameters:	
				C_i (nF)	L_i (μH)
RTD	30	2.31	17.32	0	0
SuperModule	7.14	300	887	110	0

5. The cables between this product and associated apparatus should be shielded cables. The shield should be grounded reliably in non-hazardous area.
6. The product should be used with Ex certified associated apparatus to establish explosion protection system that can be used in explosive gas atmospheres. Wiring and terminals should comply with the instruction manual of the product and associated apparatus.
7. End users are not permitted to change any components, contact the manufacturer to avoid damage to the product.
8. During installation in hazardous location, cable glands, conduit, and blanking plugs certified by state-appointed inspection bodies with DIP A20 IP66 type of protection should be used. Redundant cable entries should be blocked with blanking plugs.
9. During installation, use, and maintenance in explosive dust atmosphere, observe the warning “Do not open when an explosive dust atmosphere is present”.
10. Maintenance should be done when no explosive dust atmosphere is present.
11. During installation, use and maintenance of this product, observe following standards:
 - GB3836.13-2013 “Electrical apparatus for explosive gas atmospheres Part 13: Repair and overhaul for apparatus used in explosive gas atmospheres“
 - GB3836.15-2000 “Electrical apparatus for explosive gas atmospheres Part 15: Electrical installations in hazardous area (other than mines)”
 - GB3836.16-2006 “Electrical apparatus for explosive gas atmospheres Part 16: Inspection and maintenance of electrical installation (other than mines)”
 - GB3836.18-2010 “Intrinsically Safe System”

GB50257-1996- “Code for construction and acceptance of electric device for explosion atmospheres and fire hazard electrical equipment installation engineering”

GB15577-2007 Safety regulations for dust explosion prevention and protection

GB12476.2-2010 “Electrical apparatus for use in the presence of combustible dust”

EAC - Belarus, Kazakhstan, Russia

EM Technical Regulation Customs Union (EAC) Flameproof and Dust Ignition-proof

Certificate	RU C-US.AA87.B.00378
Markings	Ga/Gb Ex d IIC T6...T4 X Ex tb IIC T105 °C T ₅₀₀ 95 °C Db X Ex ta IIC T105 °C T ₅₀₀ 95 °C Da X

IM Technical Regulation Customs Union (EAC) Intrinsic Safety

Certificate	RU C-US.AA87.B.00378
Markings	0Ex ia IIC T4 Ga X

Japan

E4 Japan Flameproof

Certificate	TC19070, TC19071, TC19072, TC19073
Markings	Ex d IIC T6

Republic of Korea

EP Republic of Korea Flameproof

Certificate	12-KB4BO-0180X [Mfg USA], 11-KB4BO-0068X [Mfg Singapore]
Markings	Ex d IIC T6...T4

IP Republic of Korea Intrinsic Safety [HART Only]

Certificate	10-KB4BO-0021X [Mfg USA, SMMC]
Markings	Ex ia IIC T4

Combinations

K1	Combination of E1, I1, N1, and ND
K2	Combination of E2 and I2

K5	Combination of E5 and I5
K6	Combination of E6 and I6
K7	Combination of E7, I7, and N7
KA	Combination of E1, I1, E6, and I6
KB	Combination of E5, I5, E6, and I6
KC	Combination of E1, I1, E5, and I5
KD	Combination of E1, I1, E5, I5, E6, and I6
KM	Combination of EM and IM
KP	Combination of EP and IP

Additional Certifications

SBS American Bureau of Shipping (ABS) Type Approval

Certificate 00-HS145383

Intended Use Measure gauge or absolute pressure of liquid, gas or vapor applications on ABS classed vessels, marine, and offshore installations. [HART only]

SBV Bureau Veritas (BV) Type Approval

Certificate 31910

BV Requirements Bureau Veritas Rules for the Classification of Steel Ships

Application Class Notations: AUT-UMS, AUT-CCS, AUT-PORT and AUT-IMS. [HART only]

SDN Det Norske Veritas (DNV) Type Approval

Certificate A-14186

Intended Use Det Norske Veritas' Rules for Classification of Ships, High Speed and Light Craft, and Det Norske Veritas' Offshore Standards.[HART only]

Application

Location classes	
Type	3051S
Temperature	D
Humidity	B
Vibration	A
EMC	A
Enclosure	D/IP66/IP68

SLL Lloyds Register (LR) Type Approval

Certificate 11/60002

Application Environmental categories ENV1, ENV2, ENV3, and ENV5. [HART only]

Dimensional drawings

Figure 4: Transmitter with Coplanar Sensor Module and Flange (Front View)

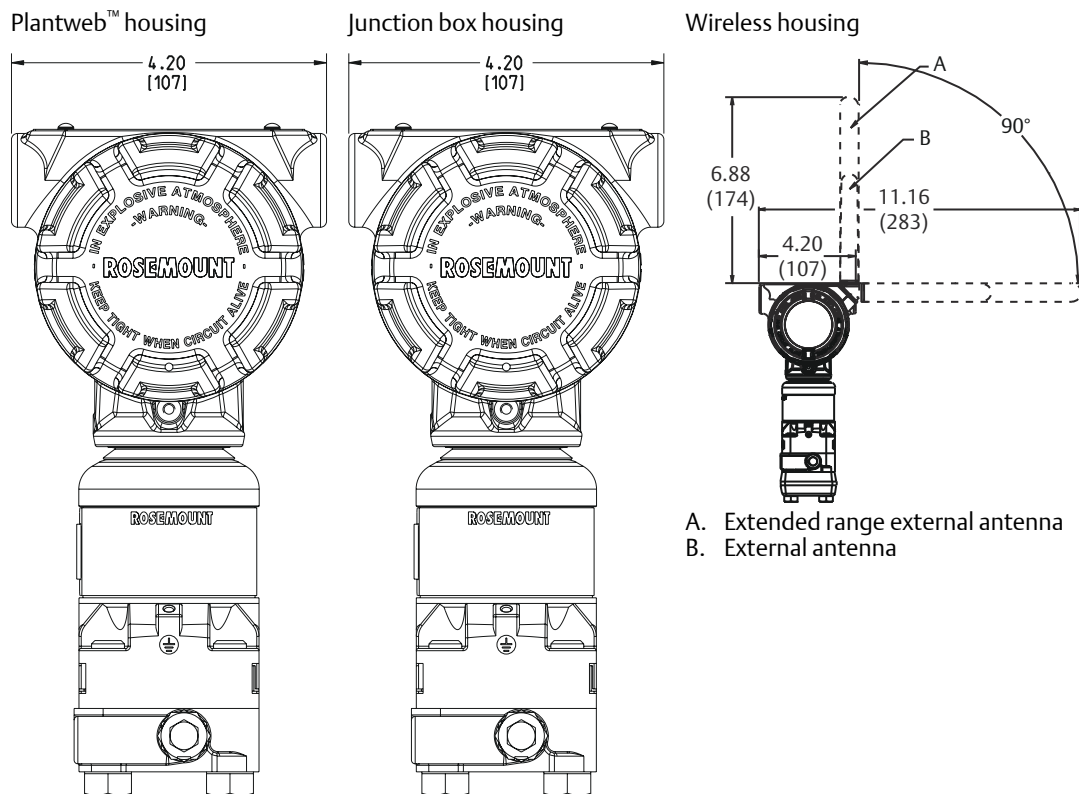

Dimensions are in inches (millimeters).

Figure 5: Transmitter with Coplanar Sensor Module and Flange (Side View)

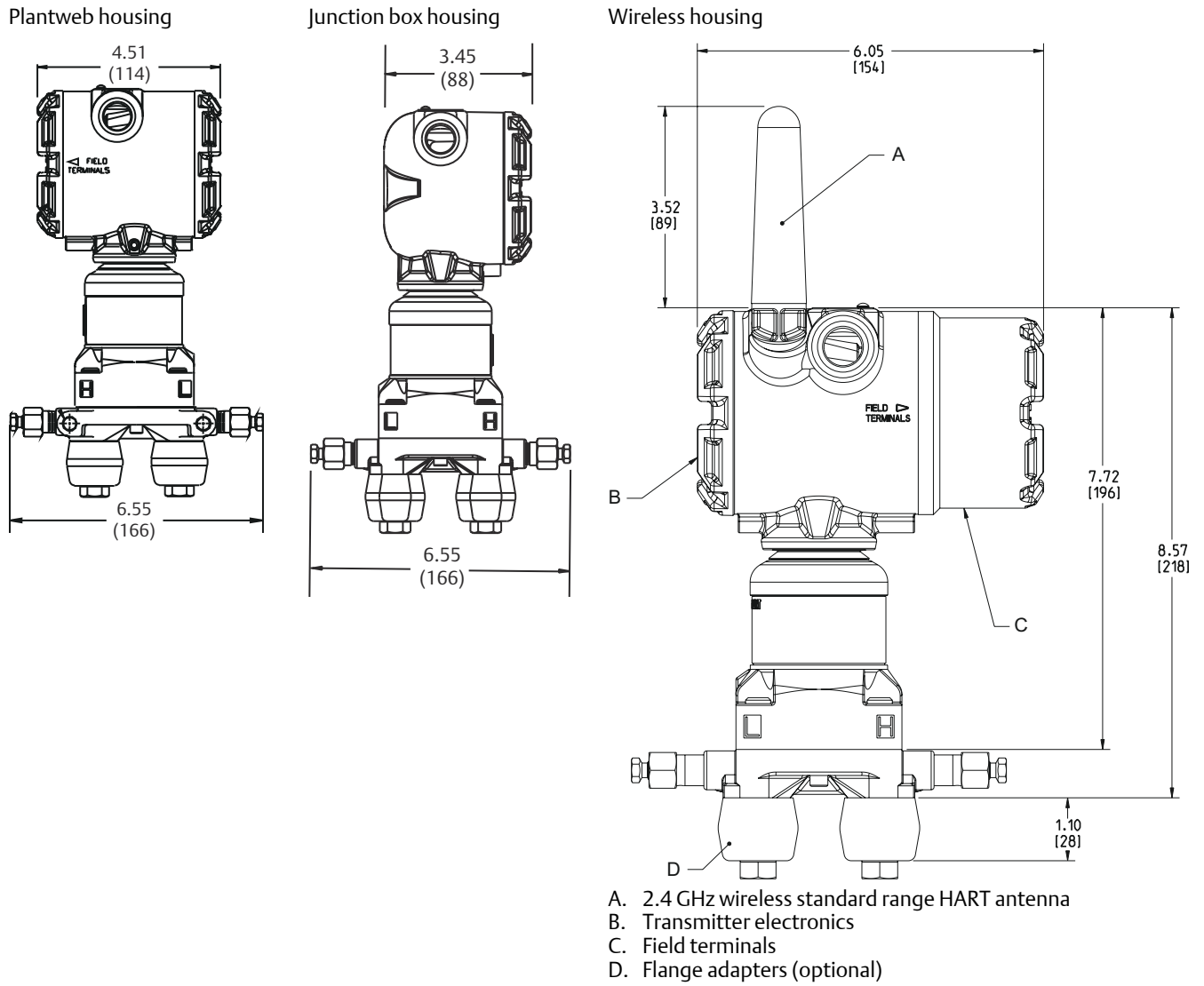

Dimensions are in inches (millimeters).

Figure 6: Transmitter with Coplanar Sensor Module and Traditional Flange (Front View)

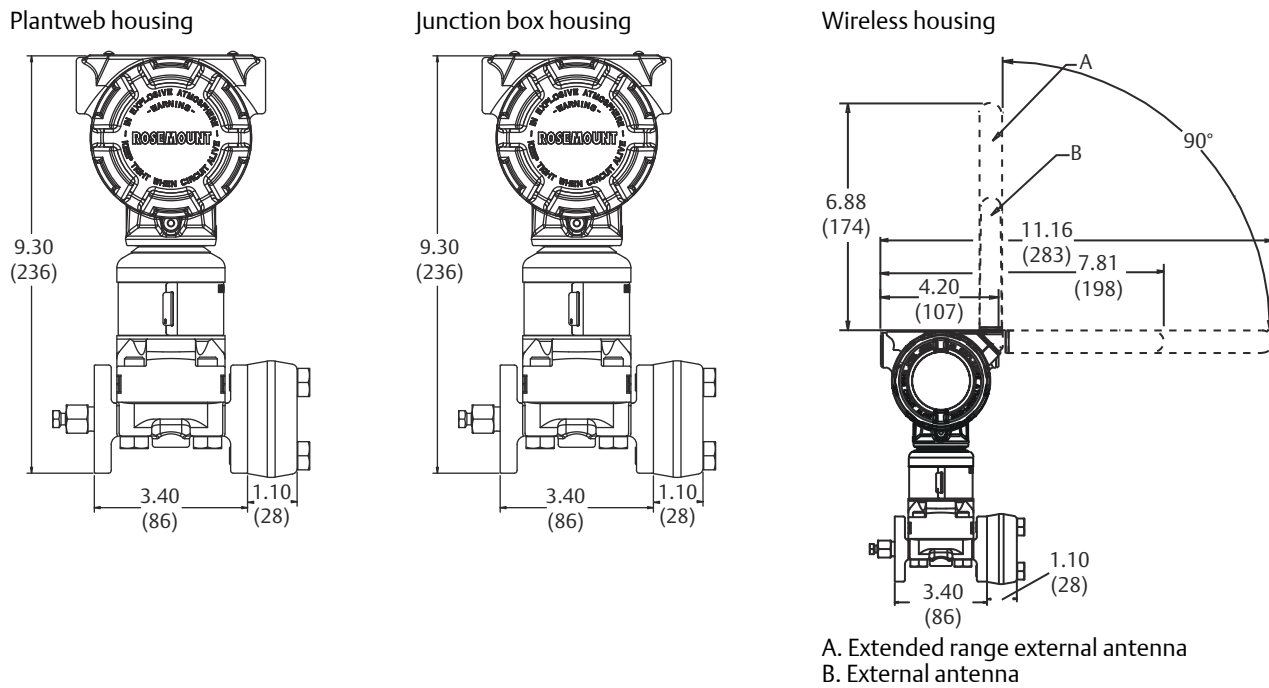

Dimensions are in inches (millimeters).

Figure 7: Transmitter with Coplanar Sensor Module and Traditional Flange (Side View)

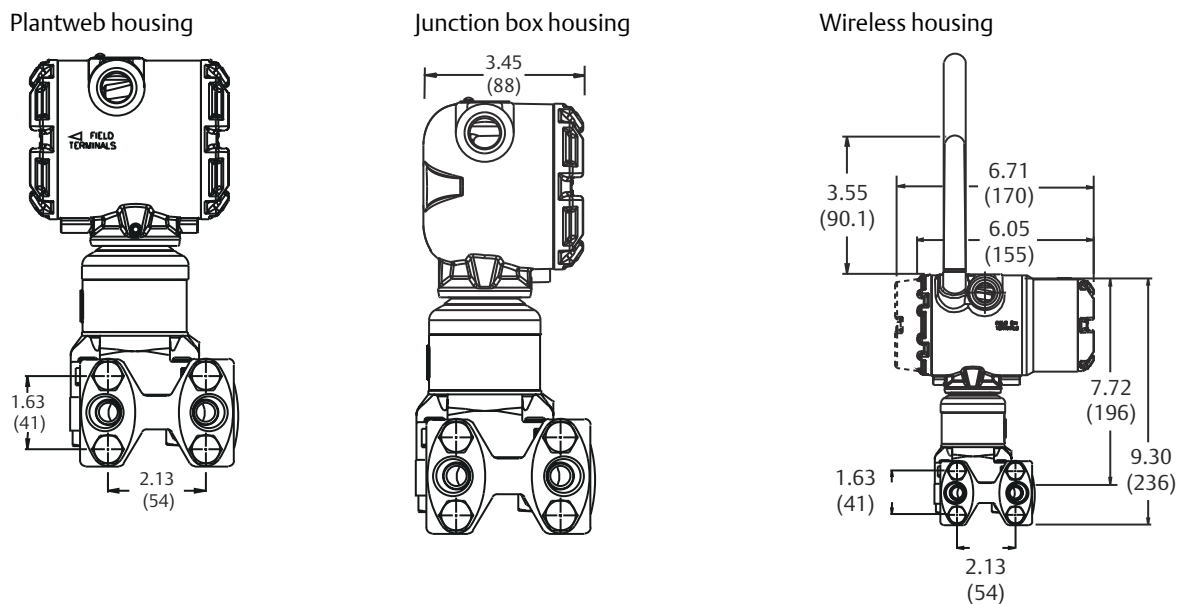

Dimensions are in inches (millimeters).

Figure 8: Transmitter with In-line Sensor Module (Front View)

Note

For ranges 1A-4A, ½-in. NPT 316L SST process wetted connection. For detailed dimensions on other configurations, see Type I drawings at Emerson.com/Rosemount.

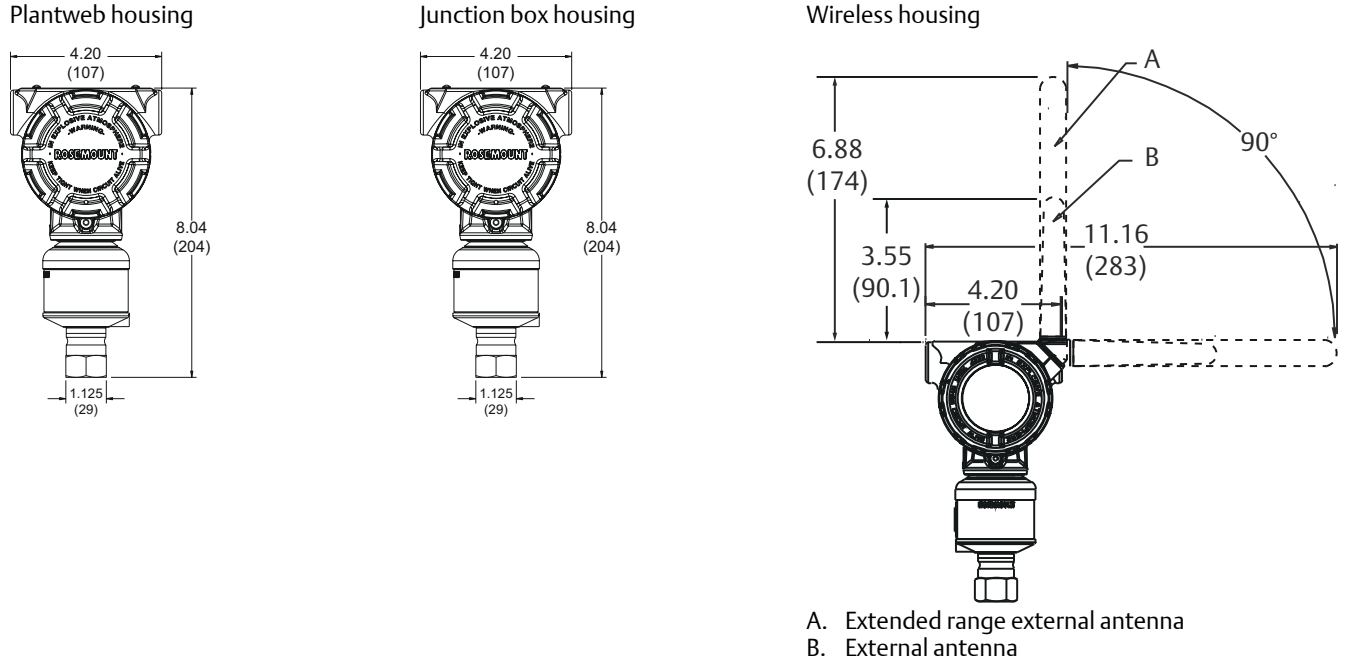

Dimensions are in inches (millimeters).

Figure 9: Transmitter with In-line Sensor Module (Side View)

Note

For ranges 1A-4A, ½-in. NPT 316L SST process wetted connection. For detailed dimensions on other configurations, see Type I drawings at Emerson.com/Rosemount.

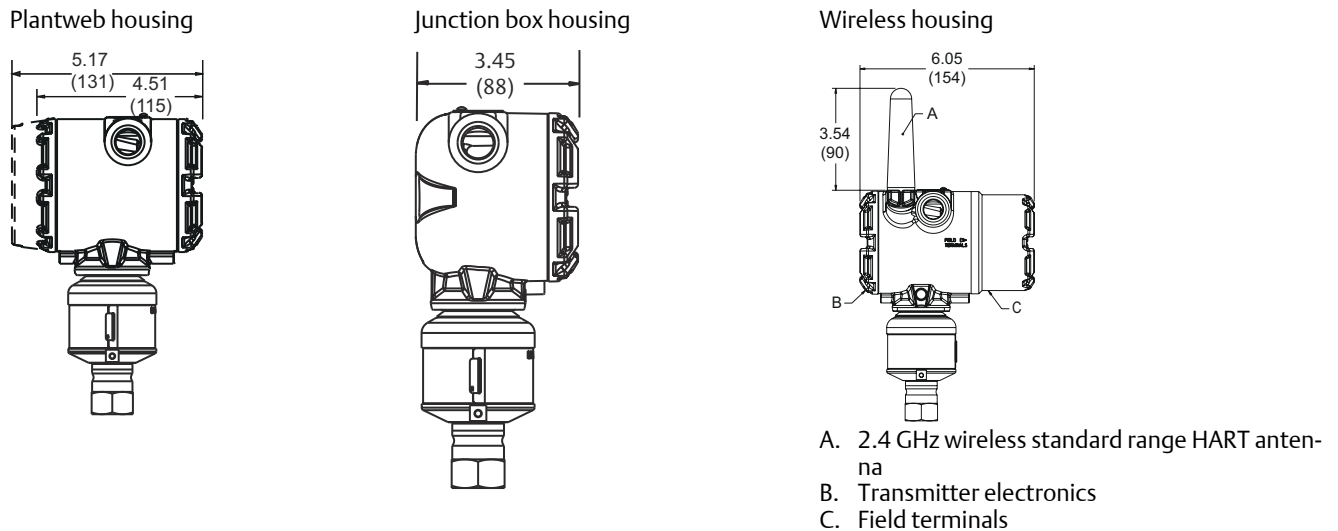

Dimensions are in inches (millimeters).

Figure 10: Plantweb Housing, Junction Box Housing, and Quick Connect with In-line SuperModule™ Platform

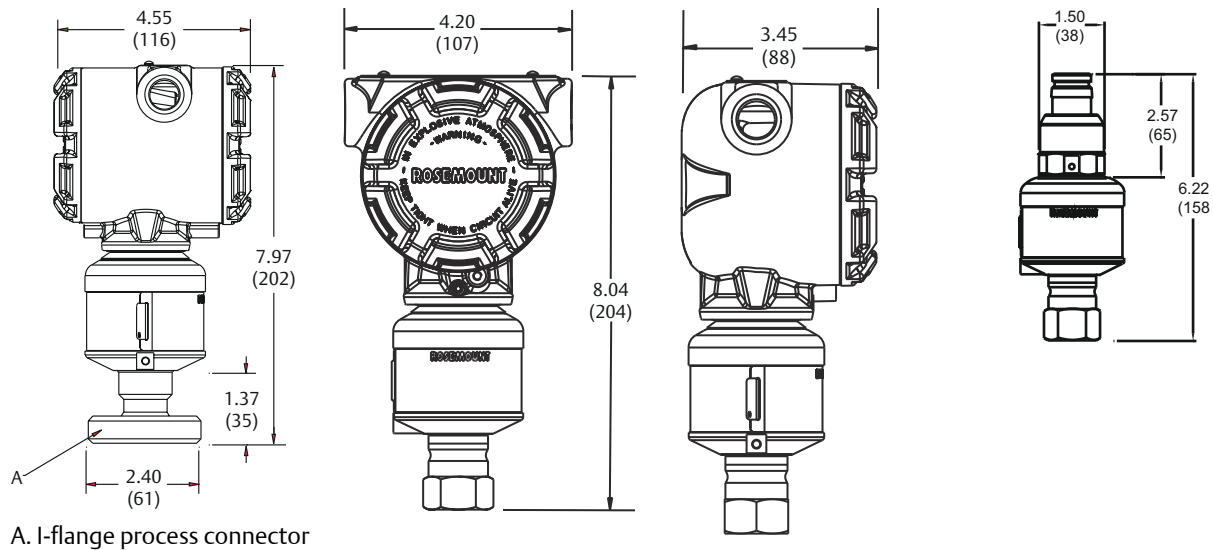

Dimensions are in inches (millimeters).

Figure 11: High Gain, Remote Mount Antenna (WN Option)

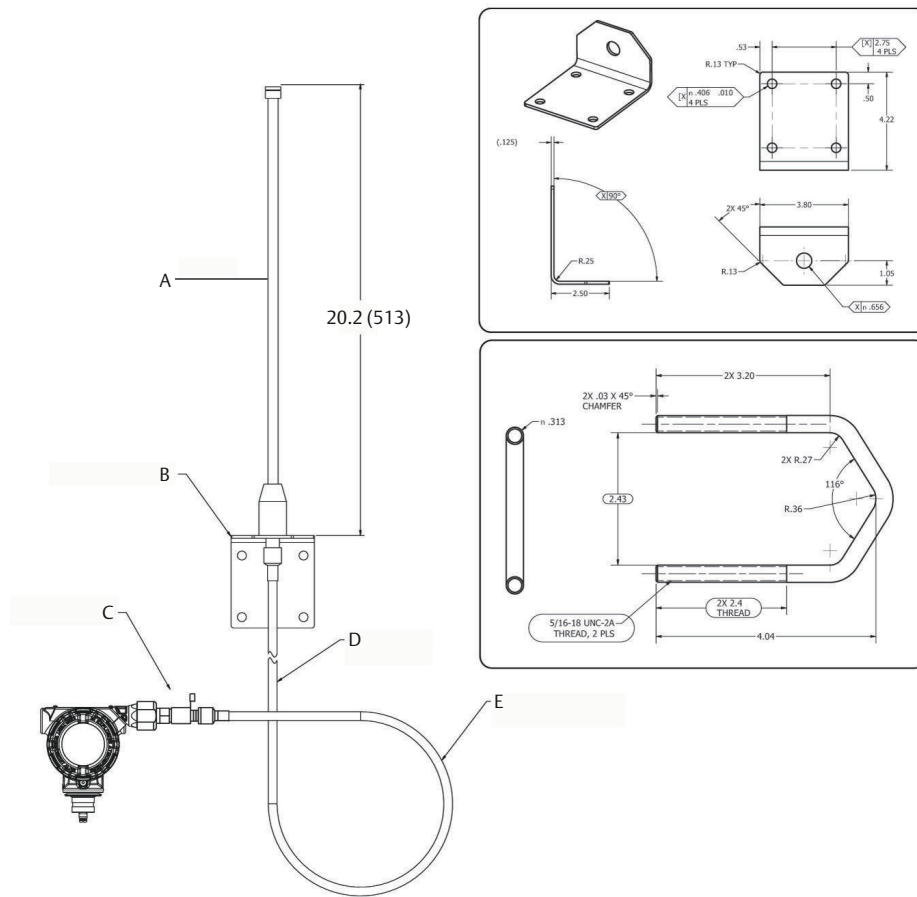

- A. Antenna
 - B. Mounting bracket
 - C. Lightning arrester
 - D. 25 ft (7,6 m) cable
 - E. Min drip loop Ø12-in. (0,3 m)
- Dimensions are in inches (millimeters).

Figure 12: Coplanar Mounting Configurations (B4 Bracket)

Pipe mount (front and side views)

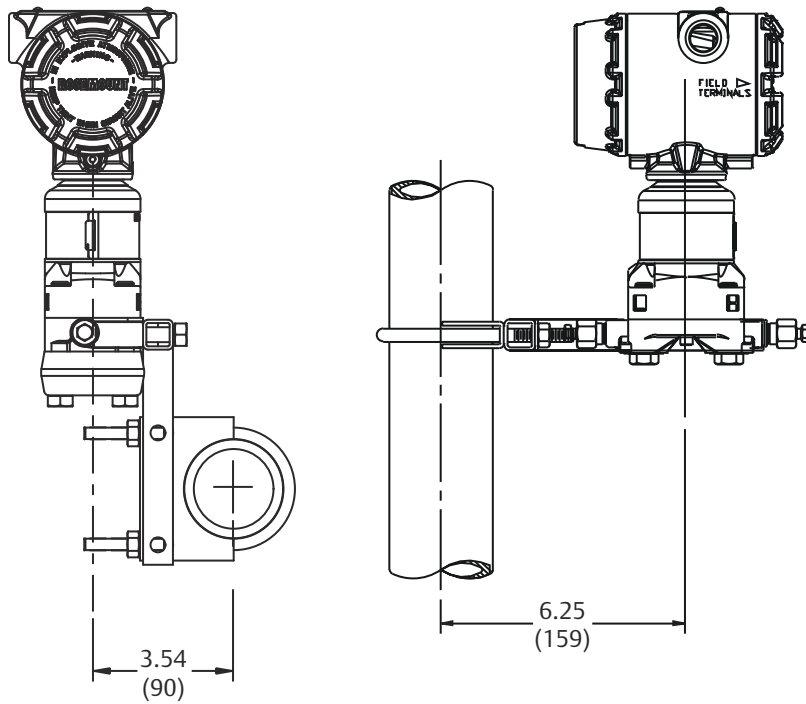

Panel mount (side view)

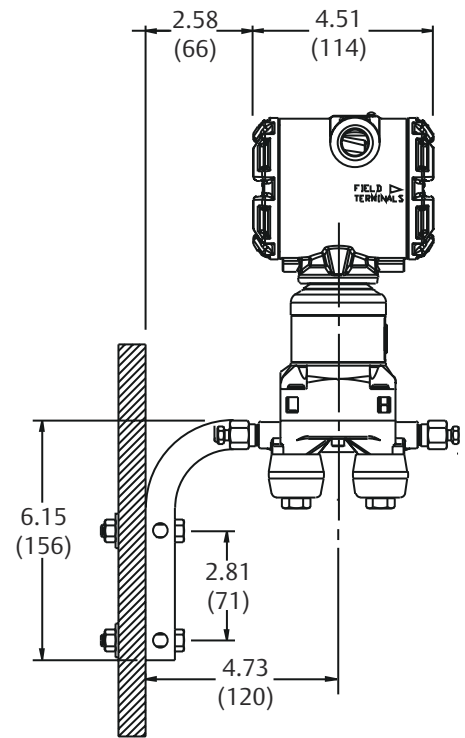

Dimensions are in inches (millimeters).

Figure 13: Traditional Mounting Configurations

Pipe mount

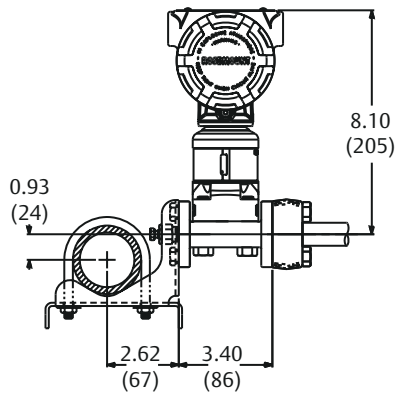

Pipe mount (flat bracket)

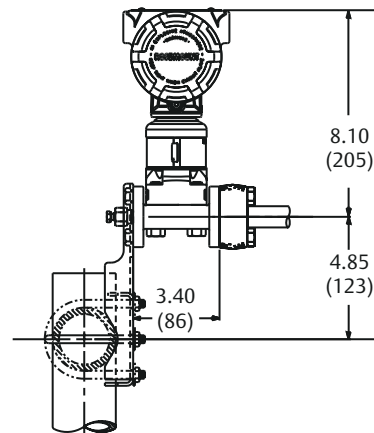

Panel mount

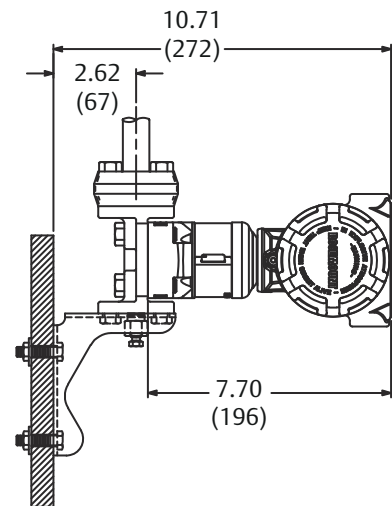

Dimensions are in inches (millimeters).

Figure 14: In-line Mounting Configurations (B4 Bracket)

Pipe mount (front and side views)

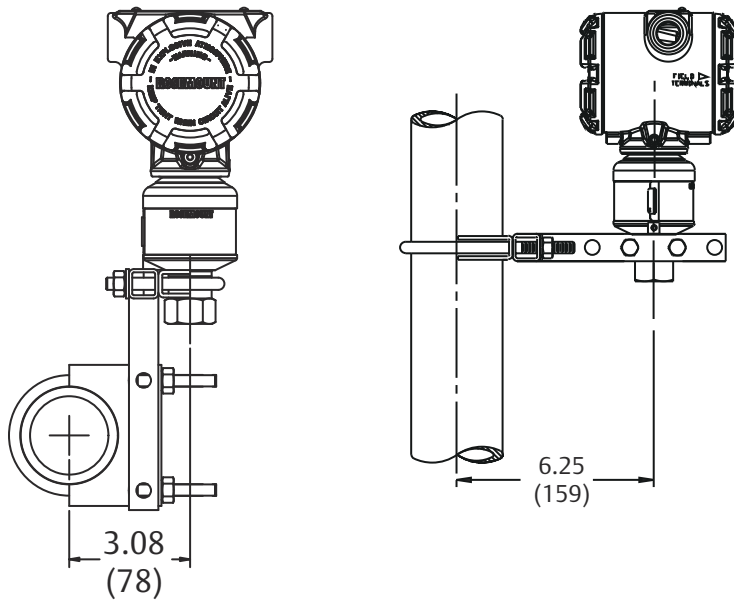

Panel mount (side view)

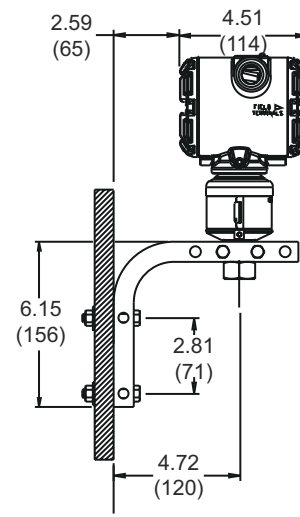

Dimensions are in inches (millimeters).

Figure 15: Remote Display Mounting Configurations (B4 Bracket)

Pipe mount (front and side views)

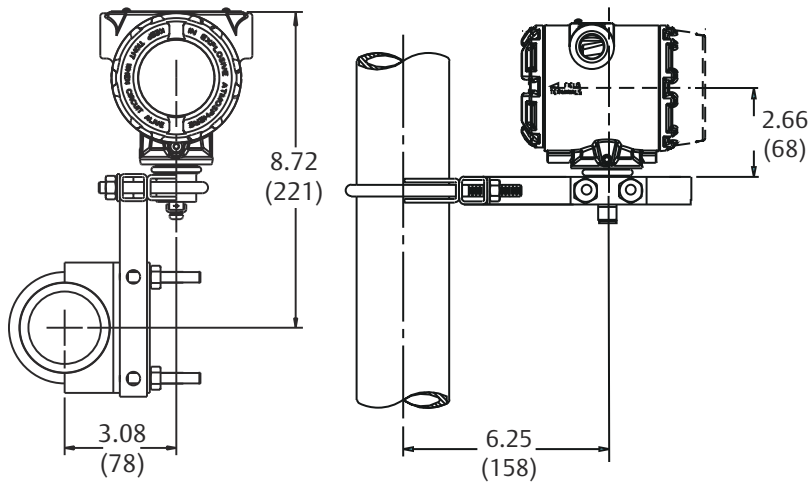

Panel mount (side view)

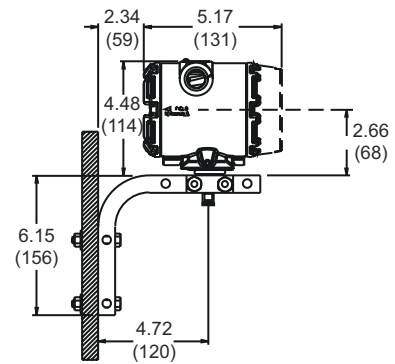

Dimensions are in inches (millimeters).

Figure 16: Rosemount 3051SFA Annubar Flow Meter

Note

The Pak-Lok Annubar model is available up to Class 600 ANSI (1440 psig at 100 °F [99 bar at 38 °C]).

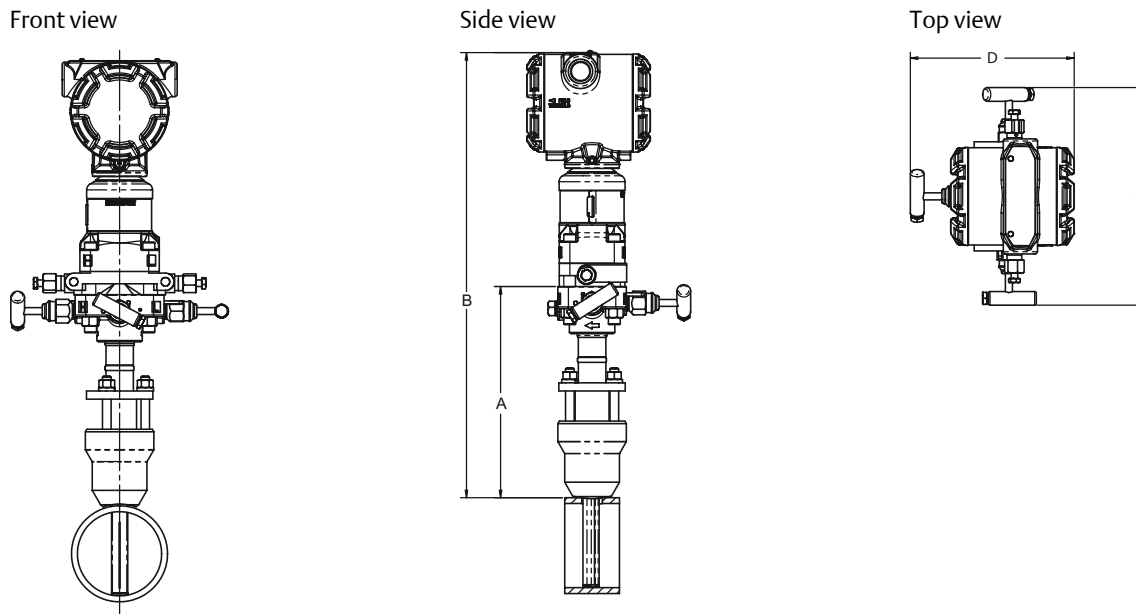

Table 62: 3051CFA Annubar Flow Meter Dimensional Data

Sensor size	A (Max)	B (Max)	C (Max)	D (Max)
1	8.50 (215,9)	17.10 (434,3)	8.66 (220,0)	7.00 (177,8)
2	11.00 (279,4)	19.60 (497,8)	8.66 (220,0)	7.00 (177,8)
3	12.00 (304,8)	20.60 (523,2)	8.66 (220,0)	7.00 (177,8)

Dimensions are in inches (millimeters).

Figure 17: Rosemount 3051SFC Compact Orifice Flow Meter (Primary Element Type code A)

Front view (orifice plate)

Side view (orifice plate)

Top view (orifice plate)

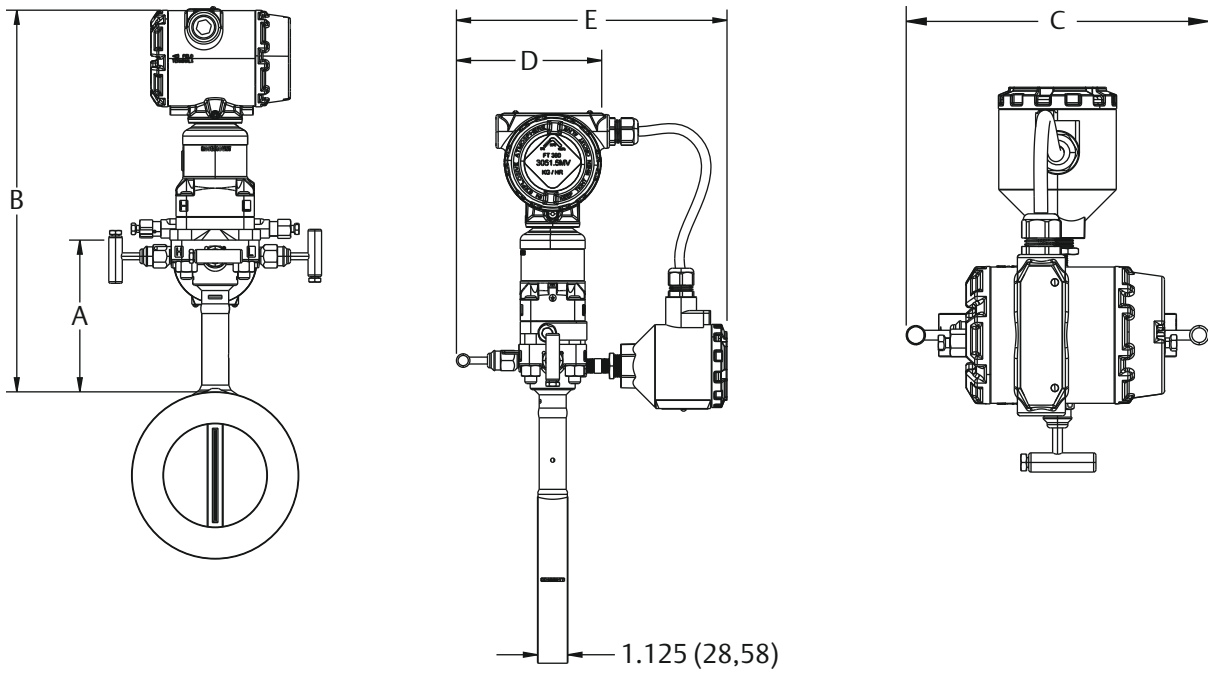

Dimensions are in inches (millimeters).

Figure 18: Rosemount 3051SFC Compact Orifice Flow Meter (Primary Element Type code C and P)

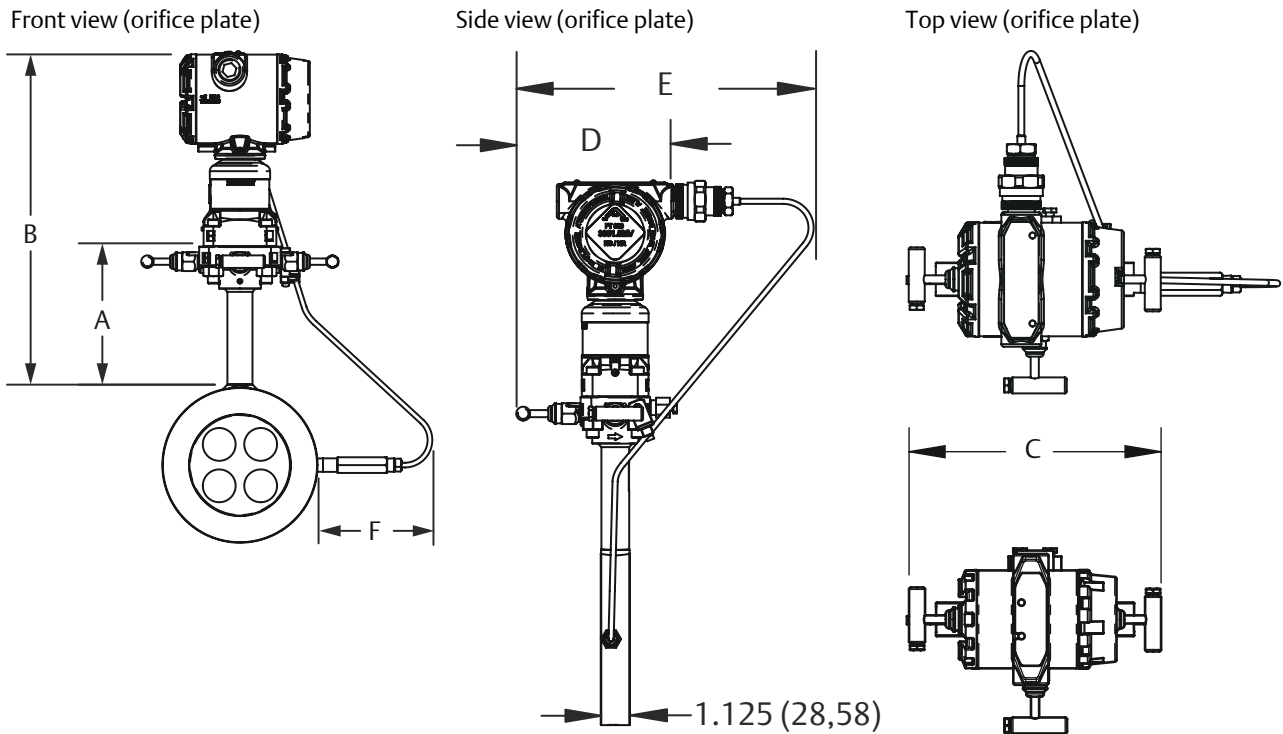

Dimensions are in inches (millimeters).

Table 63: Rosemount 3051SFC Compact Orifice Flow Meter Dimensional Data

Primary element type	A	B	Transmitter height	C	D	E	F
Type A	5.62 (143)	Transmitter Height + A	8.53 (217)	7.75 (197) - closed 8.25 (210) - open	6.00 (152) - closed 6.25 (159) - open	10.0 (254) - closed 10.25 (260,3) - open	N/A
Type P and C	5.62 (143)	Transmitter Height + A	7.70 (196)	7.75 (197) - closed 8.25 (210) - open	6.00 (152) - closed 6.25 (159) - open	10.2 (257,8) - closed 10.4 (26,2) - open	Max of 7.2 (184)

Dimensions are in inches (millimeters).

Figure 19: Rosemount 3051SFP Integral Orifice Flow Meter

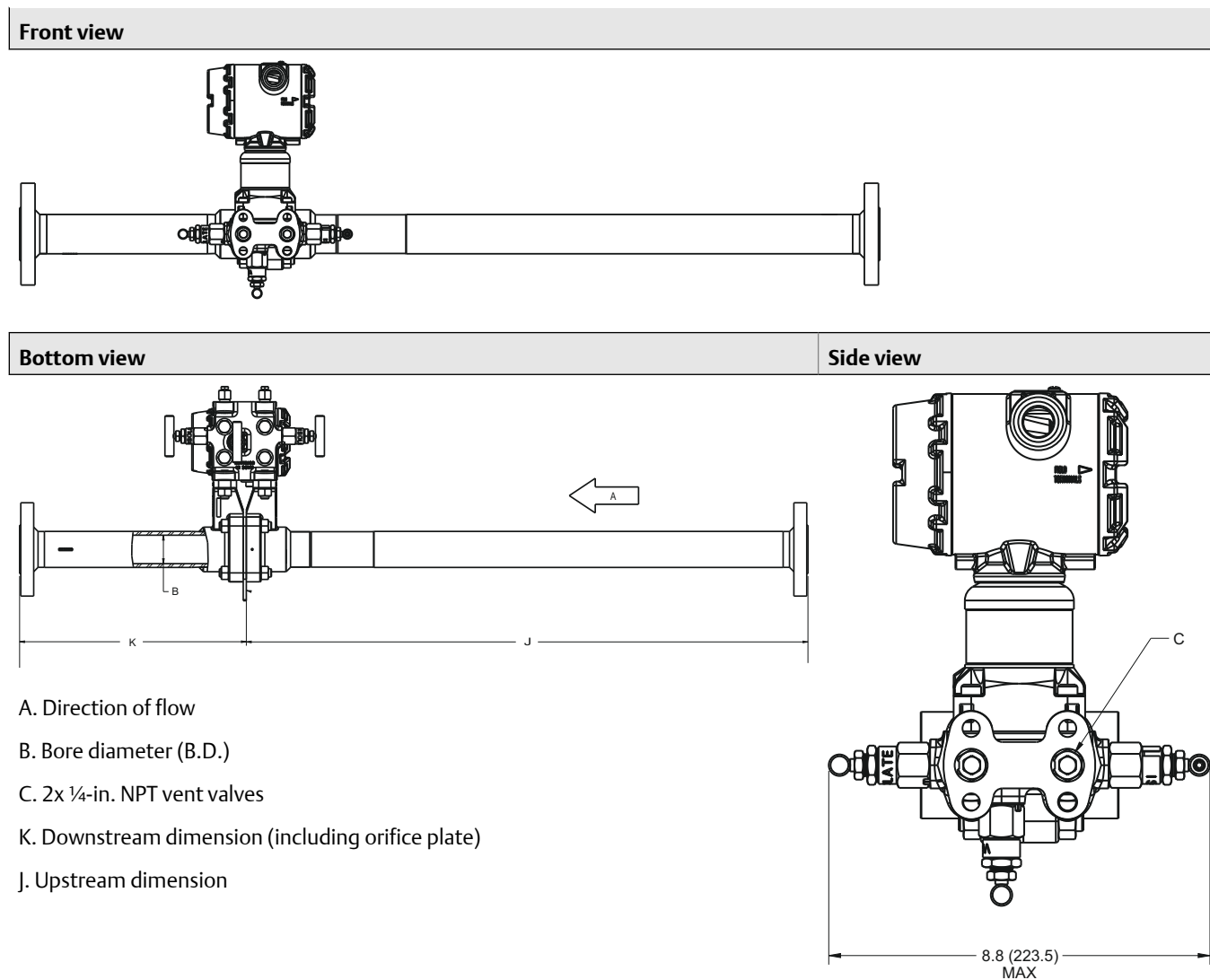

Dimensions are in inches (millimeters).

Table 64: Rosemount 3051SFP Integral Orifice Flow Meter Dimensional Data

Dimension	Line size		
	½-in. (15 mm)	1-in. (25 mm)	1½-in. (40 mm)
J (Beveled/Threaded pipe ends)	12.54 (318,4)	20.24 (514,0)	28.44 (722,4)
J (RF slip-on, RTJ slip-on, RF-DIN slip on)	12.62 (320,4)	20.32 (516,0)	28.52 (724,4)
J (RF Class 150, weld neck)	14.37 (364,9)	22.37 (568,1)	30.82 (782,9)
J (RF Class 300, weld neck)	14.56 (369,8)	22.63 (574,7)	31.06 (789,0)
J (RF Class 600, weld neck)	14.81 (376,0)	22.88 (581,0)	31.38 (797,1)
K (Beveled/Threaded pipe ends)	5.74 (145,7)	8.75 (222,2)	11.91 (302,6)
K (RF slip-on, RTJ slip-on, RF-DIN slip on) ⁽¹⁾	5.82 (147,8)	8.83 (224,2)	11.99 (304,6)
K (RF Class 150, weld neck)	7.57 (192,3)	10.88 (276,3)	14.29 (363,1)
K (RF Class 300, weld neck)	7.76 (197,1)	11.14 (282,9)	14.53 (369,2)

(1) Downstream length shown here includes plate thickness of 0.162-in. (4,11 mm).

Figure 20: Rosemount 3051S Scalable Level Transmitter with FF Seal

Note

Seal dimensions and pressure ratings can be found in the Rosemount DP Level Transmitters and 1199 Remote Seals [Product Data Sheet](#).

Note

Lower housing (flushing ring) is available with FFW style flange.

Coplanar

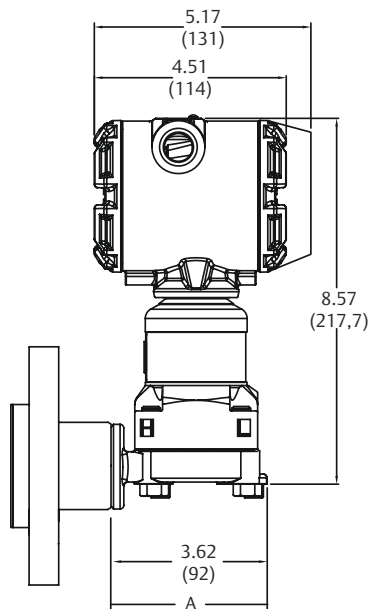

A. + Direct mount extension length

In-line

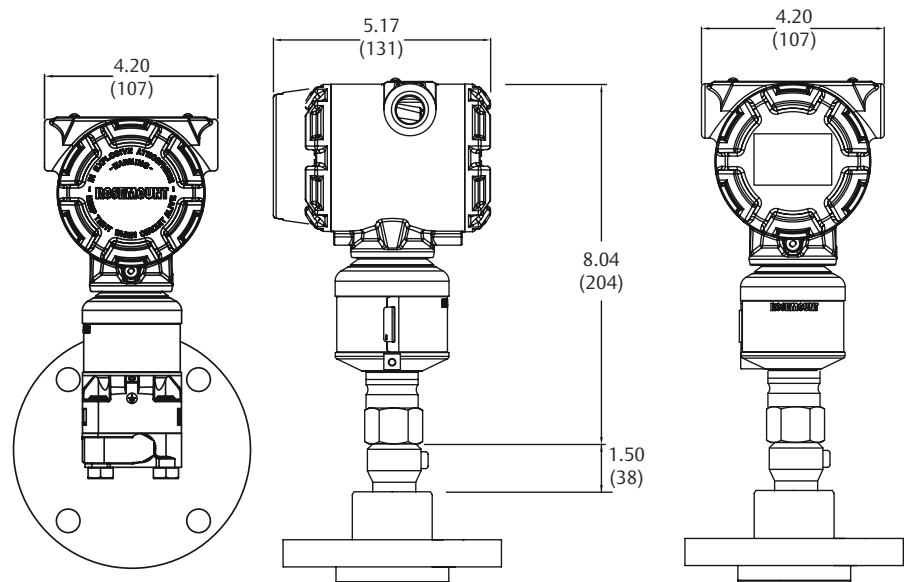

Dimensions are in inches (millimeters).

Figure 21: Rosemount 3051S Scalable Level Transmitter with EF Seal

Note

Seal dimensions and pressure ratings can be found in the Rosemount DP Level Transmitters and 1199 Remote Seals [Product Data Sheet](#).

Coplanar

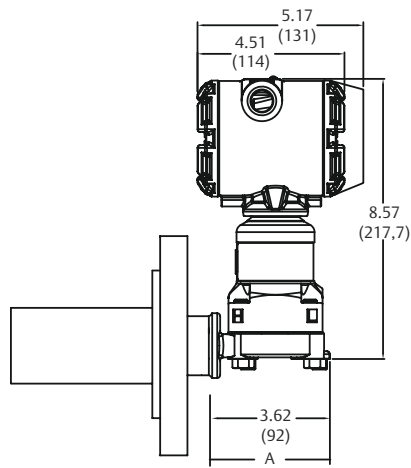

In-line

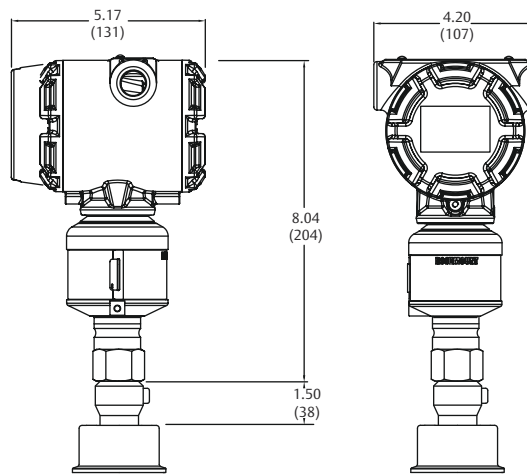

A. + Direct mount extension length

Dimensions are in inches (millimeters).

Figure 22: Rosemount 3051S Scalable Level Transmitter with RF Seal

Note

Seal dimensions and pressure ratings can be found in the Rosemount DP Level Transmitters and 1199 Remote Seals [Product Data Sheet](#).

Coplanar

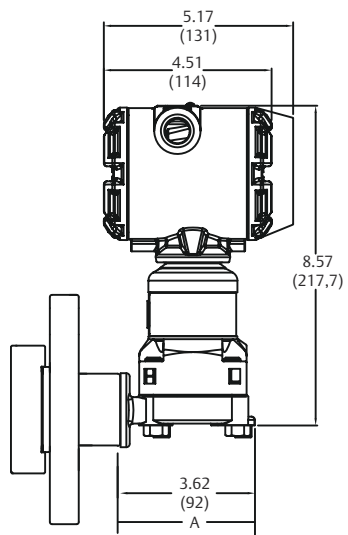

In-line

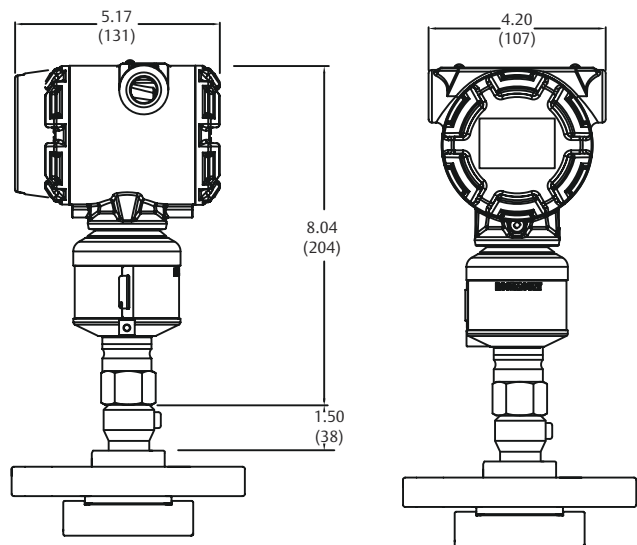

A. + Direct mount extension length

Dimensions are in inches (millimeters).

Figure 23: Rosemount 3051S Scalable Level Transmitter with RT Seal

Note

Seal dimensions and pressure ratings can be found in the Rosemount DP Level Transmitters and 1199 Remote Seals [Product Data Sheet](#).

Coplanar

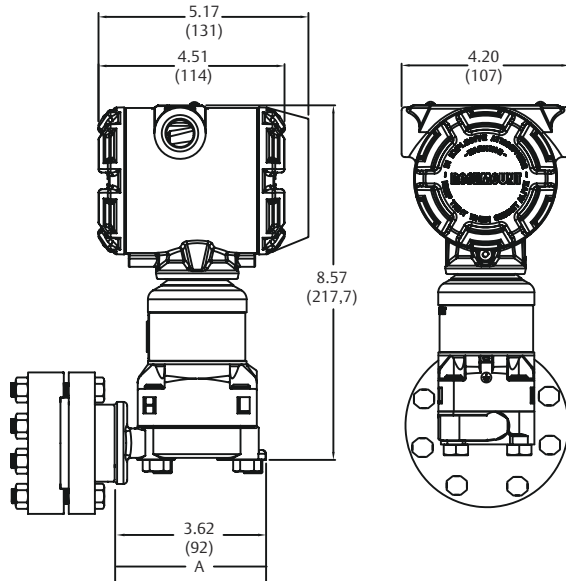

In-line

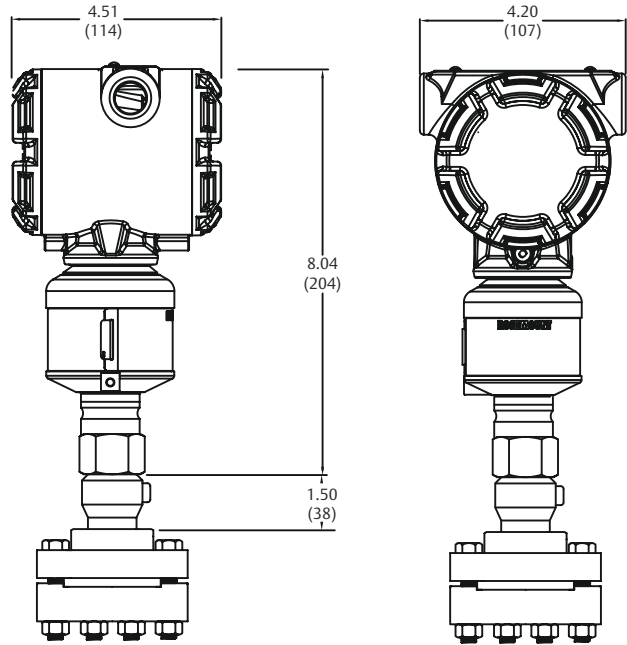

A. + Direct mount extension length

Dimensions are in inches (millimeters).

Figure 24: Rosemount 3051S Scalable Level Transmitter with SS Seal

Note

Seal dimensions and pressure ratings can be found in the Rosemount DP Level Transmitters and 1199 Remote Seals [Product Data Sheet](#).

Coplanar

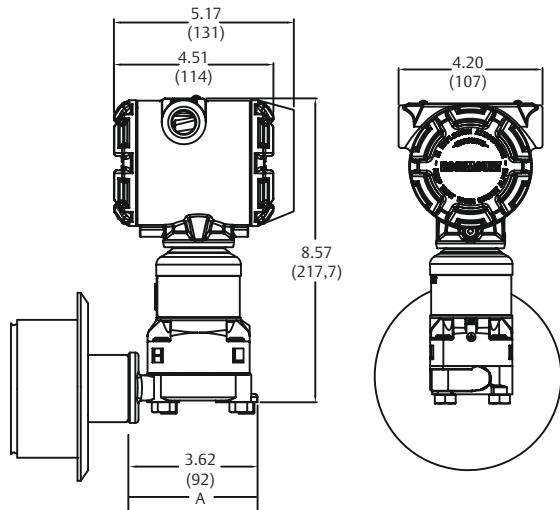

A. + Direct mount extension length

In-line

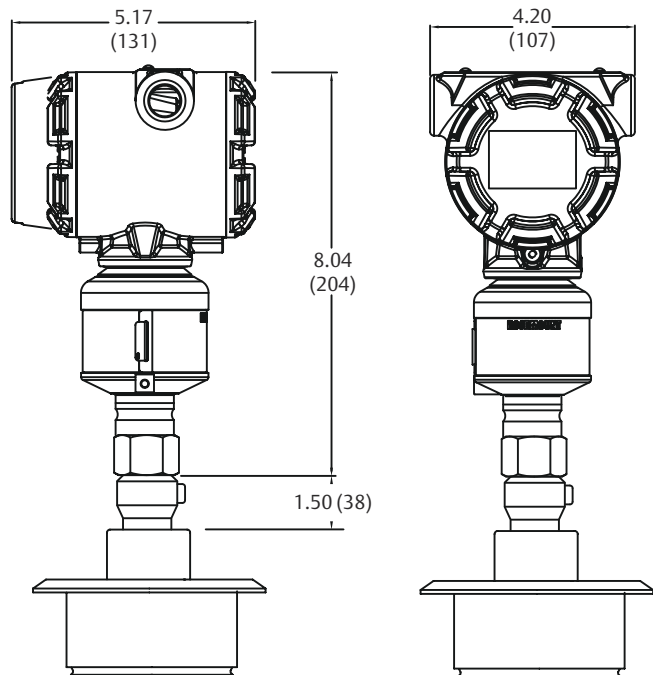

Dimensions are in inches (millimeters).

Figure 25: Rosemount 3051S Scalable Level Transmitter with SC Seal

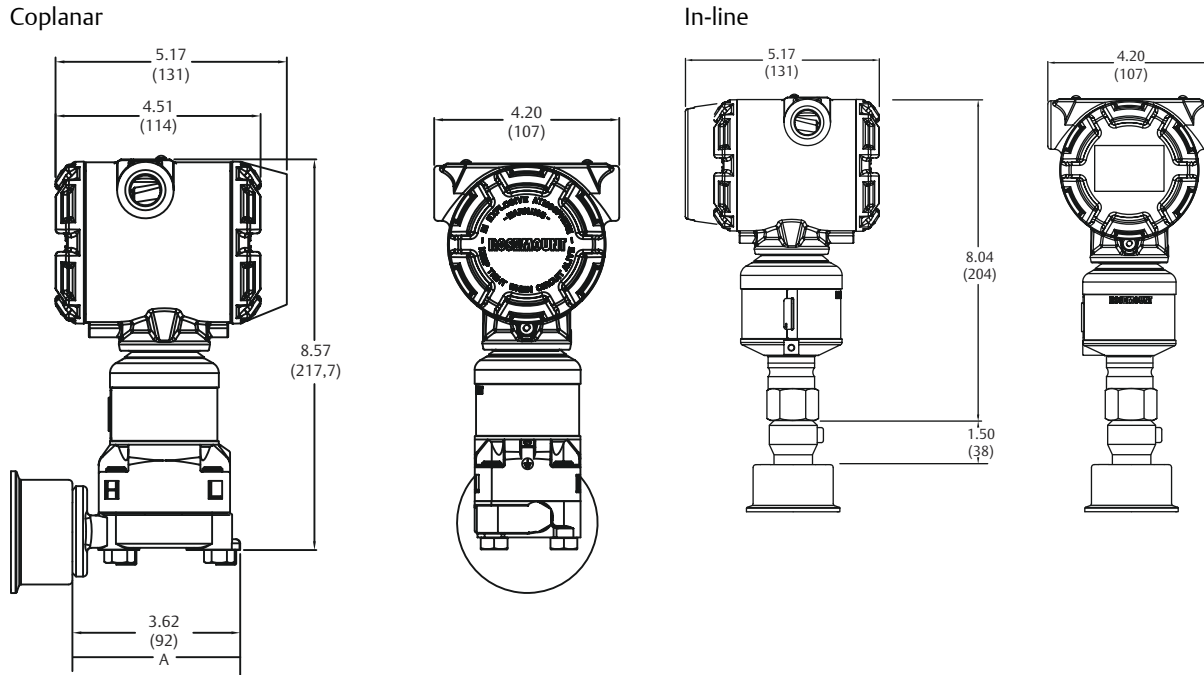

A. + Direct mount extension length

Dimensions are in inches (millimeters).

Figure 26: Rosemount 3051S Scalable Level Transmitter with Thermal Range Expander

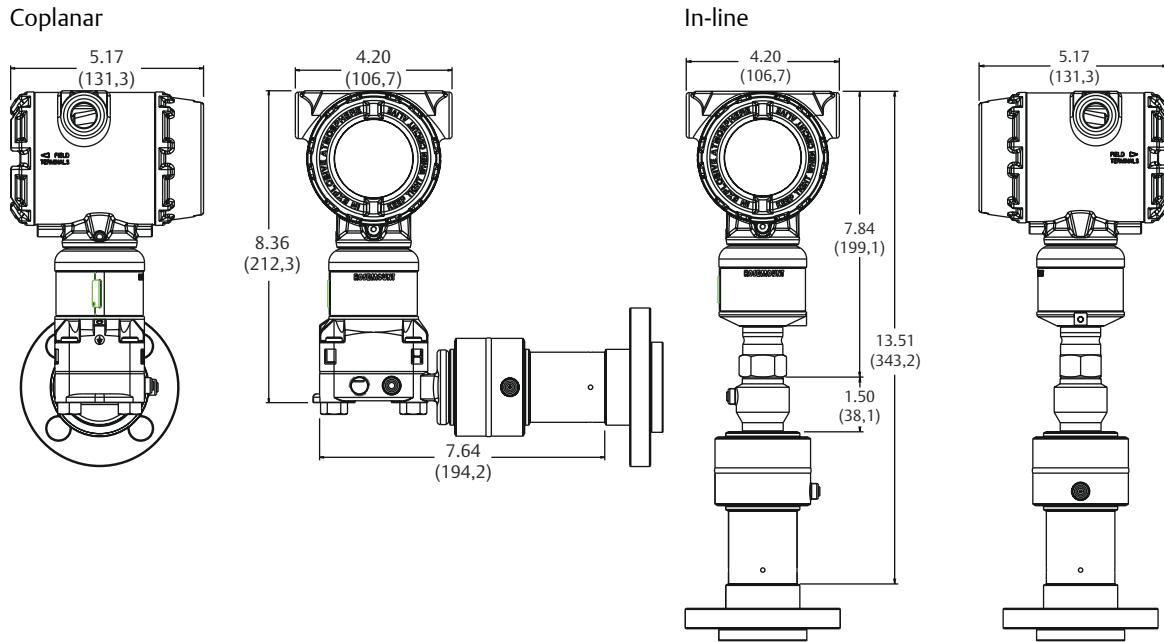

Dimensions are in inches (millimeters).

Accessories

Rosemount™ Engineering Assistant (EA) software packages

The Rosemount Engineering Assistant software supports flow configuration for the Rosemount 3051SMV. The package is available with or without modem and connecting cables. All configurations are packaged separately. For best performance of the EA software, the following computer hardware and software is recommended:

Note

Engineering Assistant version 6.1 or later requires the use of Microsoft® .NET Framework version 2.0 or later. If .NET version 2.0 is not currently installed, the software will be automatically installed during the Engineering Assistant installation. Microsoft.NET version 2.0 requires an additional 200 MB of disk space.

Minimum system requirements for Engineering Assistant 5.5.1 for the Rosemount 3051SMV FOUNDATION™ Fieldbus with fully compensated mass flow block

- Intel® Core™ Duo, 2.4 GHz
- Operating System: Windows™ 7, 32- or 64-bit
- 600 MB of available hard disk space
- USB port (for use with fieldbus interface)

Minimum system requirements for Engineering Assistant 6 for the Rosemount 3051SMV HART device

- Pentium®-grade Processor: 500 MHz or faster
- Operating System: Microsoft Windows 2000 (32-bit), Windows XP Professional (32-bit), Windows 7, or Windows 8
- 256 MB RAM
- 100 MB of available hard disk space
- RS232 serial port or USB port (for use with HART® modem)
- CD-ROM

Engineering Assistant software packages

Code	Product description
EA	Engineering Assistant Software Program
Software media	
2	EA Rev. 5 (Compatible with Rosemount 3051SMV FOUNDATION Fieldbus, Rosemount 3095, and Rosemount 333)
3	EA Rev. 6 (Compatible with Rosemount 3051SMV HART only)
Language	
E	English
Modem and connecting cables	
0	None
H	Serial port HART modem and cables
B	USB port HART modem and cables
C	FOUNDATION Fieldbus PCM-CIA Interface card and cables
License	
N1	Single PC license
N2	Site license

Code	Product description
Typical Model Number:	EA 2 E 0 N1

Accessories

Item description	Part number
Serial port HART modem and cables only	03095-5105-0001
USB port HART modem and cables only ⁽¹⁾	03095-5105-0002
FOUNDATION Fieldbus PCM-CIA Interface card and cables only	03095-5108-0001
Long-life power module for Wireless option	701PBKKF

(1) Supported by SNAP-ON™ EA with AMS Device Manager version 6.2 or higher.

Global Headquarters

Emerson Automation Solutions
6021 Innovation Blvd
Shakopee, MN 55379 USA

📞 +1 800 999 9307 or +1 952 906 8888

☎️ +1 952 949 7001

✉️ RFQ.RMD-RCC@Emerson.com

North America Regional Office

Emerson Automation Solutions
8200 Market Blvd.
Chanhassen, MN 55317, USA

📞 +1 800 999 9307 or +1 952 906 8888

☎️ +1 952 949 7001

✉️ RMT-NA.RCCRF@Emerson.com

Latin America Regional Office

Emerson Automation Solutions
Sunrise, FL 33323, USA

📞 T +1 954 846 5030

☎️ +1 954 846 5121

✉️ RFQ.RMD-RCC@Emerson.com

Europe Regional Office

Emerson Automation Solutions Europe
GmbH
Neuhofstrasse 19a P.O. Box 1046
CH 6340 Baar
Switzerland

📞 T +41 (0) 41 768 6111

☎️ +41 (0) 41 768 6300

✉️ RFQ.RMD-RCC@Emerson.com

Asia Pacific Regional Office

Emerson Automation Solutions
1 Pandan Crescent
Singapore 128461
Republic of Singapore

📞 +65 6777 8211

☎️ +65 6777 0947

✉️ Enquiries@AP.Emerson.com

Middle East and Africa Regional Office

Emerson Automation Solutions
Emerson FZE P.O. Box 17033
Jebel Ali Free Zone - South 2
Dubai, United Arab Emirates

📞 +971 4 8118100

☎️ +971 4 8865465

✉️ RFQ.RMTMEA@Emerson.com

 [Linkedin.com/company/Emerson-Automation-Solutions](https://www.linkedin.com/company/Emerson-Automation-Solutions)

 [Twitter.com/Rosemount_News](https://twitter.com/Rosemount_News)

 [Facebook.com/Rosemount](https://www.facebook.com/Rosemount)

 [Youtube.com/user/RosemountMeasurement](https://www.youtube.com/user/RosemountMeasurement)

 [Google.com/+RosemountMeasurement](https://plus.google.com/+RosemountMeasurement)

©2018 Emerson. All rights reserved.

Emerson Terms and Conditions of Sale are available upon request. The Emerson logo is a trademark and service mark of Emerson Electric Co. Rosemount is mark of one of the Emerson family of companies. All other marks are the property of their respective owners.