



Haws®

model 7603TH

120V Portable Air-Pressurized Tempered Emergency Eyewash (HazLoc)

FEATURES & BENEFITS

CONSTRUCTION

Stainless steel constructed tank makes for a solid portable unit with added resistance against corrosion and breakage.

ADDED PROTECTION

Green polyethylene plastic dust covers that release with water pressure keep the unit protected from debris up until the last second before use further optimizing operation.

VALVES

Valve comes equipped with stainless steel ball and stem for added protection against corrosion and breakage. Full continuous flow occurs with the simple push of a stainless steel flag.

SAFETY

Air pressure gauge, pressure relief valve, and fire-type air fill valve decrease the possibility of mishaps and make for a safer piece of emergency equipment.

FLOW CONTROLS

Green ABS plastic Soft-Flo anti-surge heads distribute water at a rate of .25 gpm (.9 L) when pressure is between 30 and 75 psi (2.1 and 5.1 bar).

ANSI COMPLIANCE

10 useable gallons of water provide 15 minute flushing.

TEMPERED WATER

Heated, insulated blanket provides ANSI compliant tempered potable water in operating temperatures down to -20° F (-30° C). Unit will stay tempered in non-extreme outdoor conditions (below 100° F (38° C)). Installed over the Haws model 7603.



SPECIFICATIONS

Model 7603TH is a 15-gallon (56.8 L), tempered, pressurized, hazardous location portable eyewash with a stainless steel tank, and NEMA 4 heated, insulated blanket to provide ANSI compliant tempered potable water in ambient operating temperatures between -20° F (-30° C) and 100° F (38° C). Ideal for remote locations without access to continuous potable water. 120VAC, 60Hz, 1.38A electrical requirement. Voltage options available. Power cord not provided - power connection must be made according to code using Class I Division 2 compliant equipment. Model 9082 additive not included - order separately.

OPTIONS

- ❑ Transport Cart: Model 9008 cart designed to transport all stainless steel portable eyewashes.
- ❑ Water Additive: Model 9082, bacteriostatic preservative for use in portable eyewash stations. One 8 oz. (236 ml) bottle will preserve 5 to 20 gallons (18.9 to 75.7 L) of potable water for up to four months. Four bottles per carton.

For more information, visit www.hawsco.com or call (888) 640-4297.

APPLICATIONS

Where the eyes of any person may be exposed to injurious or corrosive materials, when suitable facilities for quick flushing of the eyes needs to be provided and a continuous supply of water is not available. Although the 7603TH may be used in a wide variety of locations, it is ideal for the remote and low traffic areas where protective and mobile measures may still be needed. Emergency eyewash equipment shall be in unobstructed and accessible locations that require no more than 10 seconds for the injured person to reach. CSA certified for NEMA/Type 4 in Class 1, Division 2, Group B, C, D, T6, and Class 2, Division 2, Group F, G locations; and to ANSI/ISEA Z358.1



NOTES:

1. TO COMPLY WITH ANSI/ISEA Z358.1-2014 FOR EMERGENCY EYEWASH OR EYEWASH: EYEWASH OR EYE/FACE WASH SHALL BE POSITIONED SUCH THAT FLUSHING FLUID PATTERN IS NOT LESS THAN 33" (838mm) AND NO GREATER THAN 53" (1346 mm) FROM SURFACE ON WHICH USER STANDS; AND 6.0" (153mm) MINIMUM FROM WALL OR NEAREST OBSTRUCTION.
2. DIMENSIONS MAY VARY BY ±1/2" [12.7mm].
- 3 EYEWASH HEAD ASSEMBLY MUST BE PARALLEL TO WALL OR OBSTRUCTION TO MEET CRITERIA STATED IN ACCORDANCE TO NOTE 1.
- 4 USE DOW CORNING 832 SEALANT ON DIP TUBE THREADS; HAND TIGHTEN.
- 5 TIGHTEN CLAMP BOLTS TO 10 FT. LB. OF TORQUE.
6. FILL WITH 10 GALLONS OF CLEAN POTABLE WATER (NOTE FILL LINE ON MAIN LABEL
7. PRESSURIZE TO 75 PSI. REFILL IF PRESSURE IS LESS THAN 70 PSI.
8. INSTALL GROUNDING CLAMPS AND WIRE BETWEEN TANK AND JUNCTION BOX.
9. WHEN INSTALLING THIS UNIT, LOCAL, STATE, OR FEDERAL CODES SHOULD BE ADHERED TO FOR INSTALLATION DIMENSIONS (LOCATIONS), WASTE AND SUPPLY REQUIREMENTS OTHER THAN SHOWN.
10. MUST BE FILLED WITH WATER BEFORE CONNECTING BLANKET TO POWER SOURCE.
11. ALL MODELS MUST HAVE A GROUND FAULT PROTECTION DEVICE (30mA GFCI) FOR HEAT TRACE. ELECTRICAL CURRENTS MAY BE INSUFFICIENT TO TRIP A CONVENTIONAL CIRCUIT BREAKER. ALL INSTALLATIONS MUST BE INSTALLED IN COMPLIANCE WITH LOCAL, STATE, AND/OR FEDERAL CODES.
12. ALL POWER CONNECTIONS MUST BE MADE ACCORDING TO NEC/CEC CODE USING FLEXIBLE CONDUIT OR CABLE RATED FOR CLASS I, II, DIVISION 2 – NO RIGID CONNECTION PERMITTED. MODEL 7603TH/ 7603T240H REQUIRES MINIMUM NEMA/TYPE 4 COMPLIANT EQUIPMENT. THE CORD AND FITTINGS SELECTED MUST HAVE THE APPROPRIATE HAZARDOUS LOCATION RATING REQUIRED FOR THE INSTALLATION LOCATION.

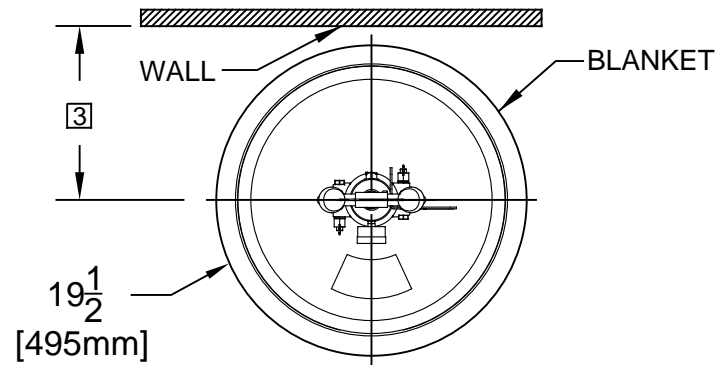

DETAILS FOR MODELS 7603TH/7603T240H WITH HEATED BLANKET

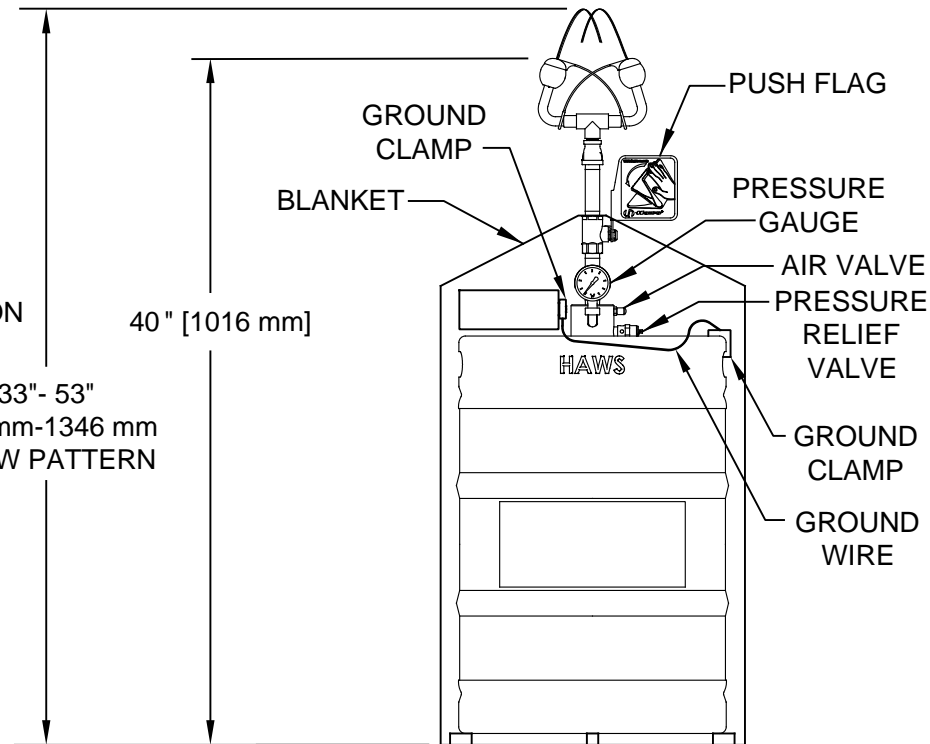
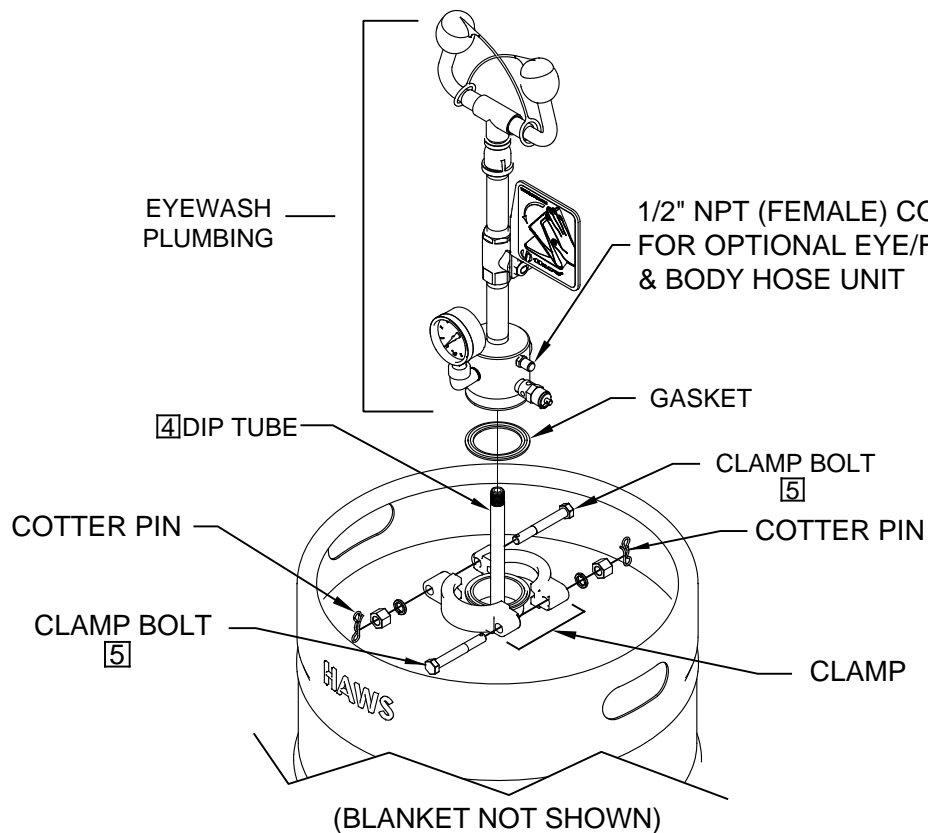

		1455 KLEPPE LANE SPARKS, NEVADA 89431 (775) 359-4712 FAX (775) 359-7424 E-MAIL: HAWS@HAWS.CO.COM WEBSITE: WWW.HAWS.CO.COM			
		ECN NO. 5235 DRAWN: CC APPROVED: MJ	REVISED PER: CC DATE: 12/28/17 DATE: 05/29/18	BY: CC CHKD.: MJ	MODEL(S) 7603TH / 7603T240H SAFETY KEG EYEWASH
SCALE: N/A		DRAWING TYPE: INSTALLATION		SIZE: A	SHEET 1 OF 1