

General-Purpose, Spring-Loaded Back-Pressure Regulators—BS(H)4, BS(H)6, and BS(H)8 Series

Features

- Diaphragm sensing: 0 to 406 psig (0 to 28.0 bar)
- Piston sensing: 0 to 5220 psig (0 to 360 bar)
- Threaded vent to monitor seal integrity

Options

- Antitamper
- Gauge connections —choice of 4 configurations
- NACE MR0175/ISO 15156-compliant models
- Special cleaning to ASTM G93 Level C



Technical Data

Series	Maximum Inlet Pressure psig (bar)	Maximum Inlet Control Pressure psig (bar)	Sensing Type	Temperature Range °F (°C)	Flow Coefficient (C _v)	Seat Diameter in. (mm)	Connections			Weight (Without Flanges) lb (kg)
							Inlet and Outlet		Gauge and Vent	
							Size	Type		
BS(H)4	BS: 1015 (70.0) BSH: 5800 (400)	BS4: 0 to 406 psig (28.0 bar) BS6, 8: 0 to 203 psig (14.0 bar) BSH: 5220 (360)	Diaphragm: BS4: 0 to 406 psig (28.0 bar) BS6, 8: 0 to 203 psig (14.0 bar) Piston: 0 to 5220 psig (360 bar)	-4 to 176 (-20 to 80) See Pressure-Temperature Ratings , page 60.	BS4: 1.84 BS6: 1.95 BS8: 2.07 with 0.39 in. (10.0 mm) seat; All: 0.49 with 0.19 in. (5.0 mm) seat	0.39 (10.0) for up to 1160 psig (80.0 bar) 0.19 (5.0) for 2175 to 5220 psig (150 to 360 bar)	1/2 in. DN15	NPT ISO/BSP parallel thread ASME or EN flange	Gauge: 1/4 in. NPT Vent: 1/8 in. ISO/BSP parallel thread	7.7 (3.5)
3/4 in. DN20							9.9 (4.5)			
1 in. DN25										

See pages 66 and 67 for flow data.

Materials of Construction

BS Series Regulator with Diaphragm Sensing and Standard Knob

BSH Series Regulator with Piston Sensing and Antitamper Option

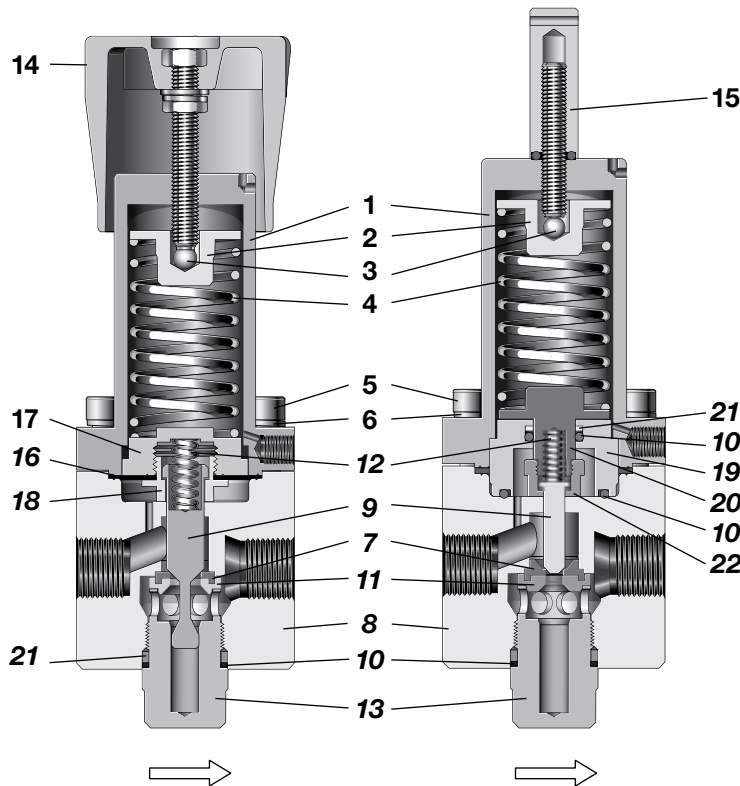

	Component	Material / Specification	
Common Components	1 Spring housing	316L SS / A479 or EN10088	
	2 Spring guide		
	3 Ball		Commercial stainless steel
	4 Set spring		302 SS
	5 Cap screw		A4-80
	6 Washer		A4
	7 Seat seal		PCTFE or PEEK
	8 Body		316L SS / A479 or EN10088
	9 Poppet		431 SS / A276
	10 O-rings		EPDM, FKM, or nitrile
	11 Seat		316L SS / A479 or EN10088
	12 Overtravel spring		302 SS / A240
	13 Body plug		316L SS / A479 or EN10088
Actuation	14 Knob assembly with adjusting screw, nuts, washers	Blue ABS with A2-70	
	15 Antitamper with O-ring, adjusting screw	316L SS and A2-70 (O-ring same as item 10)	
Sensing Mechanism	Diaphragm Only		
	16 Diaphragm	EPDM, FKM, or nitrile	
	17 Diaphragm plate	316L SS / A479 or EN10088	
	18 Diaphragm screw	316L SS / A479 or EN10088	
	Piston Only		
	19 Piston plate	316L SS / A479 or EN10088	
20 Piston			
21 Backup ring	PTFE		
22 Piston screw	316L SS / A479 or EN10088		

Wetted lubricant: Silicone-based, synthetic hydrocarbon-based.

Gauge plugs (not shown): 431 SS / A276.

Flow Data

The graphs illustrate the change in inlet or outlet pressure as the flow rate increases. For more flow curve information, contact your authorized Swagelok representative.

BS(H)4 Series

Flow Coefficient: 1.84

Maximum Inlet Pressure: BS4—1015 psig (70.0 bar); BSH4—5800 psig (400 bar)

Regulator Series

- BS4 and BSH4
- BSH4 only

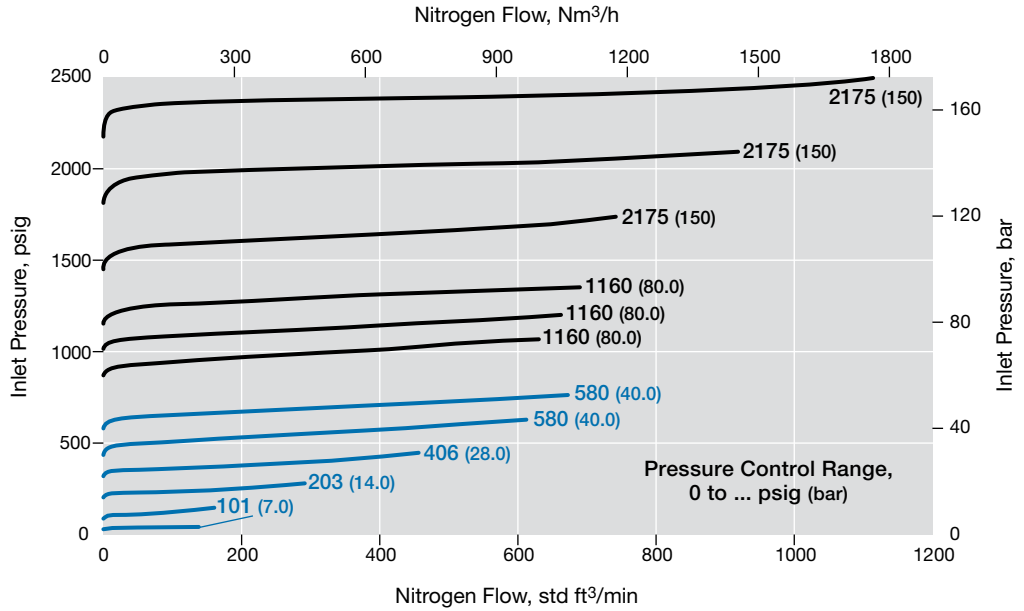

BS(H)6 Series

Flow Coefficient: 1.95

Maximum Inlet Pressure: BS6—1015 psig (70.0 bar); BSH6—5800 psig (400 bar)

Regulator Series

- BS6 and BSH6
- BSH6 only

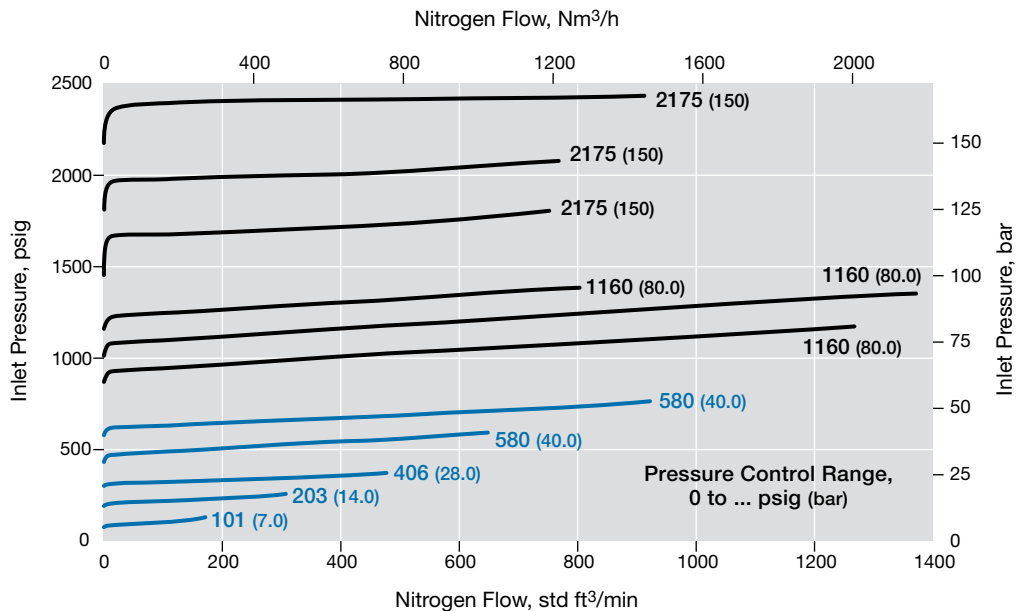

Flow Data

The graphs illustrate the change in inlet or outlet pressure as the flow rate increases. For more flow curve information, contact your authorized Swagelok representative.

BS(H)8 Series

Flow Coefficient: 2.07

Maximum Inlet Pressure: BS8—1015 psig (70.0 bar); BSH8—5800 psig (400 bar)

Regulator Series

- BS8 and BSH8
- BSH8 only

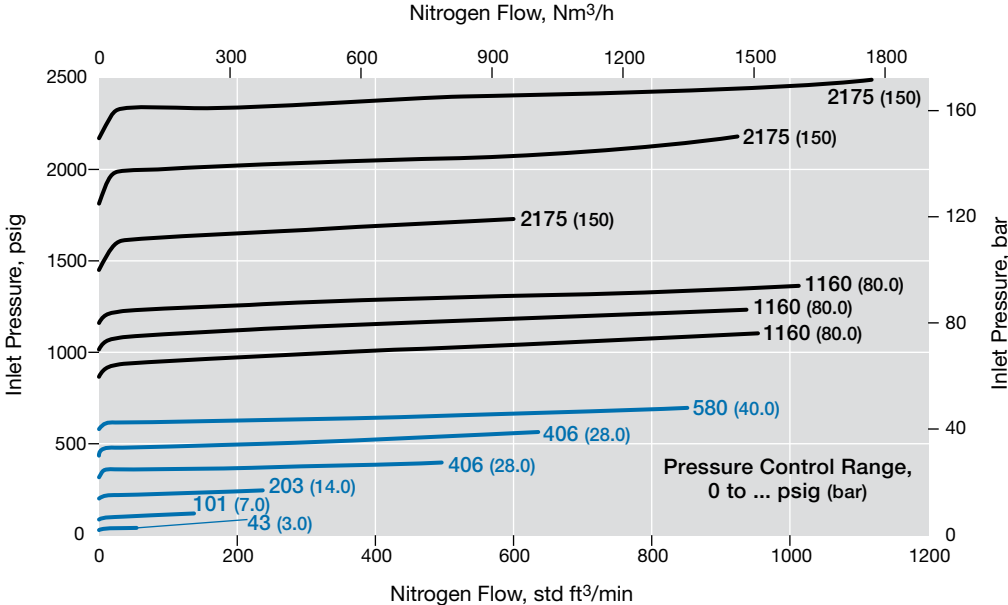

Dimensions

Dimensions, in inches (millimeters), are for reference only and are subject to change.

Series	End Connection Size	Dimensions, in. (mm)				
		A	B	C	D	E
BS(H)4	1/2 in.	9.06 (230)	2.83 (72.0)	3.07 (78.0)	2.09 (53.0)	3.62 (92.0)
BS(H)6	3/4 in.	9.25 (235)	3.23 (82.0)	3.50 (89.0)	2.20 (56.0)	3.94 (100)
BS(H)8	1 in.	9.25 (235)	3.07 (78.0)	3.50 (89.0)	2.20 (56.0)	3.94 (100)

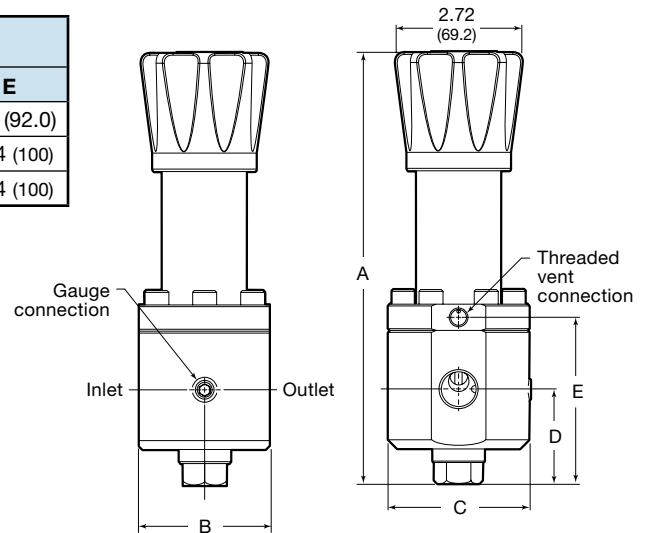
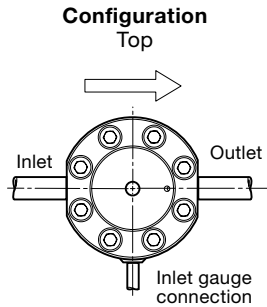
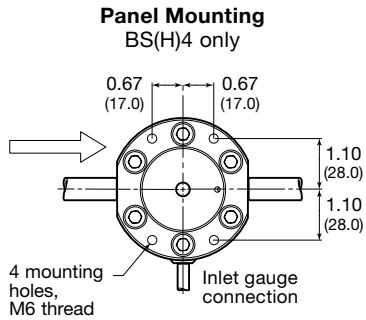

Shown with tubing for clarity; tubing not included.

Ordering Information

Build a BS(H)4, BS(H)6, and BS(H)8 series regulator ordering number by combining the designators in the sequence shown below.

1 2 3 4 5 6 7 8 9 10 11
BS FA 4 A 1 - 02 - 1 - V V K - GN2

1 Series

BS = 1015 psig (70.0 bar) maximum inlet pressure
BSH = 5800 psig (400 bar) maximum inlet pressure

2 Inlet / Outlet

B = Female ISO/BSP parallel thread
N = Female NPT
FA = ASME B16.5 flange
FD = EN 1092 (DIN) flange

3 Size

4 = 1/2 in. / DN15
6 = 3/4 in. / DN20
8 = 1 in. / DN25

4 Pressure Class

Omit designator if flanges are not ordered.
A = ASME class 150
B = ASME class 300
C = ASME class 600
E = ASME class 1500
F = ASME class 2500
M = DN class PN16
N = DN class PN40

5 Flange Facing

Omit designator if flanges are not ordered.
1 = Raised face smooth
3 = RTJ

6 Body Material

02 = 316L SS

7 Pressure Control Range

Diaphragm sensing
1 = 0 to 43 psig (0 to 3.0 bar)
2 = 0 to 101 psig (0 to 7.0 bar)
3 = 0 to 203 psig (0 to 14.0 bar)
4 = 0 to 406 psig (0 to 28.0 bar)^①
Piston sensing
4 = 0 to 406 psig (0 to 28.0 bar)^②
5 = 0 to 580 psig (0 to 40.0 bar)
6 = 0 to 1160 psig (0 to 80.0 bar)
7 = 0 to 2175 psig (0 to 150 bar)
9 = 0 to 4060 psig (0 to 280 bar)
11 = 0 to 5220 psig (0 to 360 bar)

^① BS(H)4 series only.
^② BS(H)6 and BS(H)8 series only.

8 Seal Material

V = Fluorocarbon FKM
N = Nitrile
E = EPDM

9 Diaphragm / Piston O-Rings

V = Fluorocarbon FKM
N = Nitrile
E = EPDM

10 Seat Seal Material

K = PCTFE
P = PEEK

11 Options

A = Antitamper
GN1 = Gauge connection, see below
GN2 = Gauge connection, see below
GN5 = Gauge connection, see below
 None = Standard connection, see below

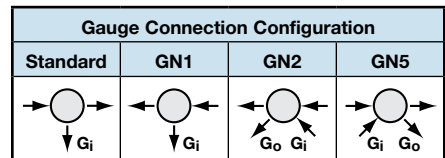

N = NACE MR0175/ISO 15156
G93 = ASTM G93 Level C-cleaned