



# INSTALLATION, OPERATION & MAINTENANCE INSTRUCTIONS

1455 Kleppe Lane ♦ Sparks, NV 89431-6467 ♦ (775) 359-4712 ♦ Fax (775) 359-7424  
E-mail: [haws@hawsco.com](mailto:haws@hawsco.com) ♦ website: [www.hawsco.com](http://www.hawsco.com)

No. 2080105 (13)

## Model 8100 Drench Shower

**NOTE TO INSTALLER: Please leave this information with the Maintenance Department.**

### LIMITED WARRANTY

HAWS warrants that this specific product is guaranteed against defective material or poor workmanship for a period of **one year from date of shipment**. HAWS liability under this warranty shall be discharged by furnishing without charge F.O.B. HAWS Factory any goods, or part thereof, which shall appear to the Company upon inspection to be of defective material or not of first class workmanship, provided that claim is made in writing to Haws within a reasonable period after receipt of the product. Where claims for defects are made, the defective part or parts shall be delivered to the Company, prepaid, for inspection. HAWS will not be liable for the cost of repairs, alterations or replacements, or for any expense connected therewith made by the owner or his agents, except upon written authority from HAWS, Sparks, Nevada. HAWS will not be liable for any damages caused by defective materials or poor workmanship, except for replacements, as provided above. Buyer agrees that Haws has made no other warranties either expressed or implied in addition to those above stated, except that of title with respect to any of the products or equipment sold hereunder and that HAWS shall not be liable for general, special, or consequential damages claimed to arise under the contract of sale.

The emergency equipment manufactured by HAWS is warranted to function if installation and maintenance instructions provided are adhered to. The units also must be used for the purpose for which they were intended. This product is intended to supplement first-aid treatment. Due to widely varying conditions, Haws cannot guarantee that the use of this emergency equipment will prevent serious injury or the aggravation of existing or prior injuries.

**NO OTHER WARRANTIES EXPRESSED OR IMPLIED ARE AUTHORIZED, PROVIDED OR GIVEN BY HAWS.**

**SHOULD YOU EXPERIENCE DIFFICULTY WITH THE INSTALLATION OF THIS MODEL PLEASE CALL:**

**TECHNICAL SUPPORT: 1-800-766-5612**

**FOR CUSTOMER SERVICE: 1-888-640-4297**

**LOCATION OF UNIT:** The Model 8100 Emergency Shower should be installed in close proximity to potential accident areas. It should be clearly identified, free from obstructions and easy to access.

**SUPPLY LINE:** The minimum recommended line size is 1-1/4" NPT with 30-90 psi (2-6 ATM) flowing pressure. Where sediment or mineral content is a problem, an inlet filter is recommended.

**PLUMBING CONNECTIONS:** Inlet supply connection is female 1-1/4" NPT.

## INSTALLATION PROCEDURE

Refer to Installation Drawing for clarification. Check parts list to insure all required parts are included. Use pipe joint sealant PST #565 (Loctite) on all connections.

- STEP 1:** Prepare the emergency shower foundation by using the floor flange assembly as a template. Locate the three holes for the 3/8-16 UNC x 6" anchor bolts (not supplied). They should extend 1" above the floor level.
- STEP 2:** Once the concrete foundation is ready (dry), assemble the floor flange assembly to the anchor bolts; then securely fasten with 3/8-16 UNC Hex Nuts and 3/8" washers (not supplied). Seal and tighten floor flange and coupling making certain the foot control holes are facing side to side.
- STEP 3:** Assemble nipple (1-1/4" x 33") to the floor flange assembly and tighten with a pipe wrench.
- STEP 4:** Assemble in the following order:  
Attach intermediate coupling to nipple (1-1/4" x 33")  
Attach plugged nipple (1-1/4" x 24") and tee (1-1/4") onto the coupling.  
Attach nipple (1-1/4" x 24") onto the tee.  
Attach tee (1-1/4" x 1-1/4" x 1") onto nipple.  
Attach nipple (1" x 9") valve assembly onto tee (1-1/4" x 1-1/4" x 1")  
Assemble the street elbow (1") onto nipple (1" x 12-1/2").  
Attach nipple onto valve.
- STEP 5:** Attach the showerhead onto street elbow (1").
- STEP 6:** Assemble the sign onto the unit. Use the strap, screws, washers and nuts provided to mount the sign onto the upright. The sign should be positioned for maximum visibility
- STEP 7:** Insert the galvanized plug into the optional supply line tee that is not used. Before connecting the supply water line to the emergency shower, **FLUSH THE LINE THOROUGHLY.**

<b>TROUBLESHOOTING</b>	
<b>PROBLEM</b>	<b>REPAIR CHECKLIST</b>
1. No flow.	1. Check the main shut-off valve.
2. Water leak between joints or fittings.	2. Tighten loose connections. If leak persists, the application of hot water will sometimes reseal improperly applied joint compound. After 30 minutes wait and retest, a persistent leak will necessitate reassembly and additional sealant.
3. Insufficient water flow at shower.	3. a. Verify minimum 30 psi (2 ATM) flowing supply line pressure.  b. Probable clogging of flow control inside shower head. Unscrew shower head off of elbow and clean rubber flow control.
4. Water does not drain properly.	4. Check your drain system for debris. Check the main waste line of your building to see if it does handle the capacity required for the entire drainage system.

For more information about Haws products, see our website: [www.hawesco.com](http://www.hawesco.com)

ITEM	DESCRIPTION	PART NO.
1	SHOWER HEAD	SP829
2	VALVE ASSEMBLY	SP260
3	SHOWER SIGN	SP177
4	PULL ROD	SP200
5	FLOOR FLANGE	SP75
6	STRIPED POLE TAPE	SP185
7	TEST TAG	SP170

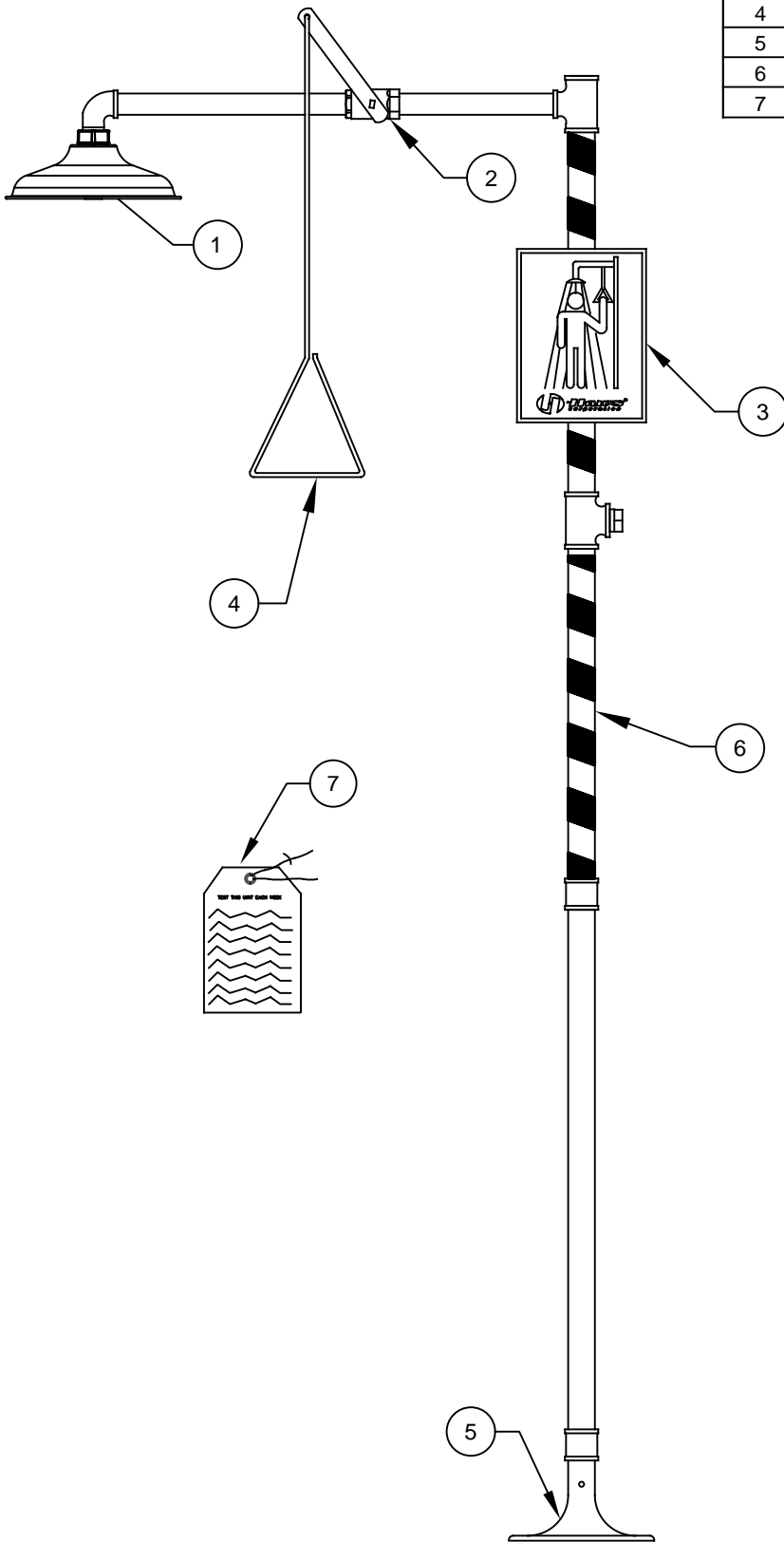

# PARTS BREAKDOWN

WHEN ORDERING PARTS PLEASE SPECIFY MODEL NUMBER.

		<b>Haws</b> <sup>®</sup>		1455 KLEPPE LANE SPARKS, NEVADA 89431 (775) 359-4712 FAX (775) 359-7424 E-MAIL: HAWS@HAWS.CO.COM WEBSITE: WWW.HAWS.CO.COM		
				ECN NO. REVISED PER BY ECN: 5279 VWC	MODEL(S) 8100 DRENCH SHOWER	PART NUMBER 0002080105
DRAWN CLF	DATE 3/8/93	CHKD VWC	REVISION 13			
APPROVED FV	DATE 02/16/18	SCALE: NA	DRAWING TYPE: PARTS BREAKDOWN	SIZE: A	SHEET 1 OF 1	

NOTES:

1. WHEN INSTALLING THIS UNIT, LOCAL, STATE, OR FEDERAL CODES SHOULD BE ADHERED TO FOR INSTALLATION DIMENSIONS (LOCATIONS), WASTE AND SUPPLY REQUIREMENTS OTHER THAN SHOWN.
2. TO COMPLY WITH ANSI Z358.1-2014 FOR EMERGENCY SHOWER EQUIPMENT:
  - SHOWER SHALL BE POSITIONED SUCH THAT SHOWER HEAD IS NO LESS THAN 82" (2083mm) AND NO GREATER THAN 96" (2438mm) FROM SURFACE ON WHICH USER STANDS.
  - SHOWER SPRAY PATTERN SHALL HAVE A MINIMUM DIAMETER OF 20" (508mm) AT 60" (1524mm) ABOVE SURFACE ON WHICH USER STANDS, AND CENTER OF SPRAY PATTERN SHALL BE LOCATED NO LESS THAN 16" (406mm) FROM NEAREST OBSTRUCTION.
3. DO NOT USE REGULAR PIPE SEALANT. IF NECESSARY USE DOW CORNING 832 SEALANT; PLACING FIVE SMALL BEADS ON MALE THREADS, JUST ABOVE FIRST THREAD.
4. DIMENSIONS MAY VARY BY  $\pm 1/2"$  (13 mm).

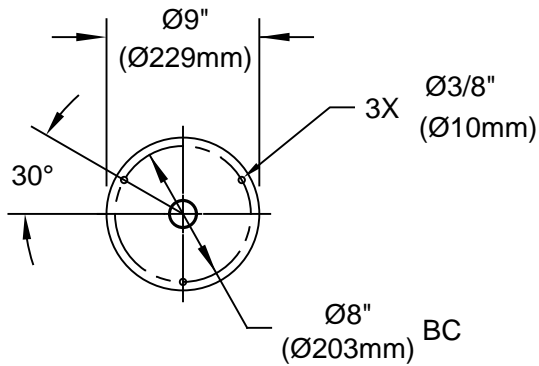

MOUNTING DETAIL

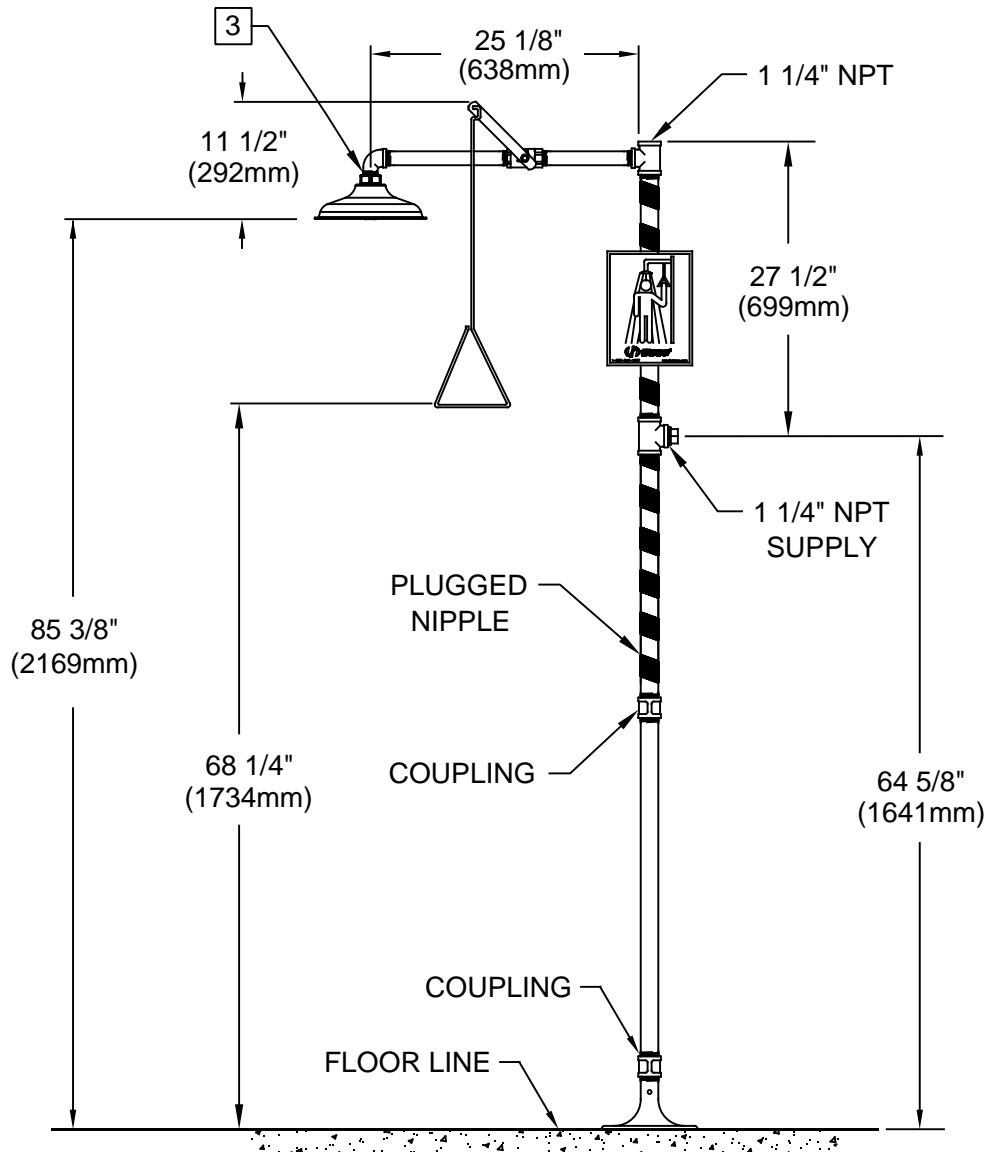

1455 KLEPPE LANE  
SPARKS, NEVADA 89431  
(775) 359-4712 FAX (775) 359-7424  
E-MAIL: HAWS@HAWS.CO.COM  
WEBSITE: WWW.HAWS.CO.COM

ECN NO.	REVISED PER	BY:	MODEL(S)	PART NUMBER
	ECN: 5279	VWC		0002080105.D
DRAWN:	DATE:	CHKD.:	8100 DRENCH SHOWER	
CH	8/91	VWC		
APPROVED:	DATE:			13
FV	02/16/18	SCALE:	NA	DRAWING TYPE:
		INSTALLATION		SIZE: A
				SHEET 1 OF 1