

8460SRC Replacement Chassis for Scully ST-6 and Biclops[®] Monitors

Installation and Wiring Instructions Manual

Manual Part Number: H52332PA

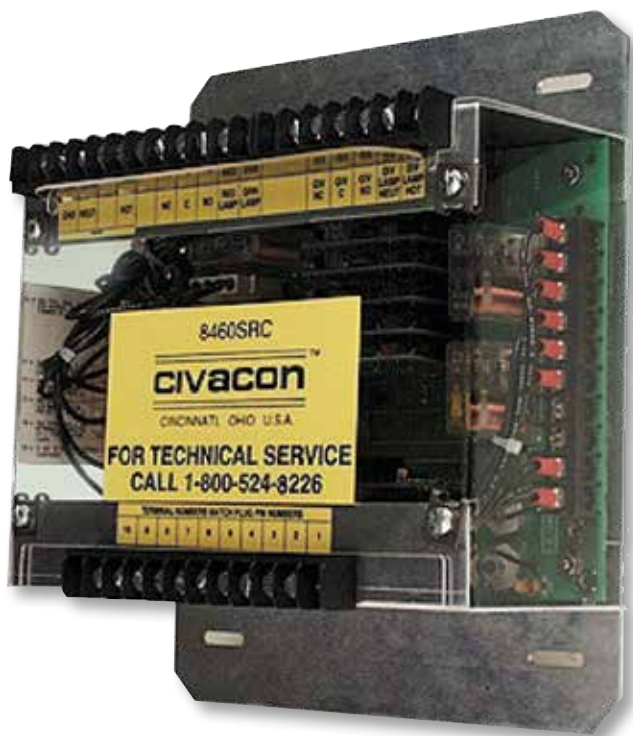

OPTI-THERM[®] is a registered trademark of CIVAcon, A Dover Company
QUICK-START[®] is a registered trademark of CIVAcon, A Dover Company
Biclops[®] is a registered trademark of the Scully Signal Company, Wilmington MA
Scully is a trademark of the Scully Signal Company, Wilmington MA

API = American Petroleum Institute
IS = Intrinsically Safe

8460SRC Replacement Chassis for Scully ST-6 and Biclops[®] Monitors

Installation and Wiring Instructions Manual

Manual Part Number: H52332PA

Table of Contents

| Section Description | Page |
|---|------|
| 1 Product Description..... | 3 |
| 2 System Operation | 4 |
| 3 Installation Instructions | 5 |
| 4 Ground Verification Wiring Installation | 9 |
| 5 Power and Automation Connections..... | 13 |
| 6 Checkout Procedure | 13 |
| 7 Warranty..... | 16 |

Table of Figures

| Figure # Description | Page |
|--|------|
| Figure 1 Mechanical Assembly Drawing..... | 6 |
| Figure 2 Front Cover Labels for the Enclosure | 7 |
| Figure 3 Internal Replacement Labels | 8 |
| Figure 4 System Control Diagram | 10 |
| Figure 5 Biclops [®] System Wiring | 11 |
| Figure 6 ST-6 System Wiring | 12 |

OPTI-THERM[®] is a registered trademark of CIVACON, A Dover Company
QUICK-START[®] is a registered trademark of CIVACON, A Dover Company
Biclops[®] is a registered trademark of the Scully Signal Company, Wilmington MA
Scully is a trademark of the Scully Signal Company, Wilmington MA

API = American Petroleum Institute
IS = Intrinsically Safe

1. Product Description

This manual describes the installation, operation, and troubleshooting of the Civacon 8460SRC Scully replacement chassis. It is intended to help operators, maintenance men, and specifiers understand the operation and features of the 8460SRC system. Some of the information in this manual has come from the field experience of our sales representatives and customers. It is recommended reading this manual before installation of any equipment.

The 8460SRC chassis is a loading rack mounted monitoring system designed to replace the existing Scully ST-6 or Biclops® internal chassis. The 8460SRC provides API compatible operation to all API thermistor and optic overfill systems. The 8460SRC replacement chassis requires simple hand tools and makes use of existing API plug, cord, and wiring connections. The 8460SRC also provides upgrade features including automatic switching and internal ground verification.

Automatic switching does not require the operator to work the confusing optic/thermistor selection switches. Use of the internal ground verification feature will require additional wiring connections to both the API plug and automation system. Communication of Ground Verification and Overfill PERMIT is achieved through separate relay output contacts. Monitor status is displayed through the existing red and green status lights on the Scully enclosure. The CIVACON Model 8460SRC replacement chassis is suitable for Class I, Division 1, Group D hazardous locations with intrinsically safe outputs, when mounted in an explosion proof enclosure per these instructions.

Do not apply power to the monitor without reading this manual and thoroughly checking all connections. If your unit is a 120VAC unit, it will operate satisfactorily within a range of voltage from 105VAC to 125VAC.

ATTENTION:

Be sure to check the local electrical and fire codes for proper installation. Many localities require an inspection to be performed before circuits are energized.

CAUTION:

DO NOT apply power to this monitor without thoroughly reading this manual and checking all connections. **DO NOT** connect a power source other than what's marked on the label to this monitor, as this may permanently damage it.

2. System Operation

The purpose of the Civacon **OPTI-THERM® Model 8460SRC** replacement chassis is to detect a liquid point level signal from a sensor mounted in compartments of a tank truck, or storage tanks. The system provides an automatic signal to the rack automation equipment to shut-off the flow of liquid, and warn of an impending overflow condition of a tank truck or storage tank.

The **OPTI-THERM® Model 8460SRC** replacement chassis uses self-checking principles to provide a continuous check on all system components. This is accomplished by the exchange of digital pulses between sensor and rack monitor. These digital pulses must pass through all active components in the sensor, sensor wiring, and back to the control monitor to test all the components in the circuit. If at any time the circuit detects a failure in any of the components, it reverts to a fail safe condition, NON-PERMISSIVE. The unit must then be repaired before it can return to an operational condition. Sensors and probes cannot be “jumpered” out of the circuit.

The **OPTI-THERM® Model 8460SRC** replacement **OPTI-THERM® Model 8460SRC** chassis provides an “AUTO-SWITCH” capability between API optic signal format and API thermistor signal format. The monitor statically remains in the OPTIC mode, providing optic signals to terminals 2 and 4 on the monitor, which **OPTI-THERM® Model 8460SRC OPTI-THERM® Model 8460SRC** correspond to pins 4 and 6 on an optic plug. The monitor also monitors channel 5 (pin 8 of a thermistor plug) for a thermistor signal. If one is detected, it switches the optic signal tracks going to terminals 2 and 4 off, and the input terminals over to thermistor channels 2 and 4.

The monitor will work with any API 5 wire OPTIC sensor. The monitor only uses 4 of the 5 wires, because the fifth wire is used for onboard monitor diagnostics ONLY. Up to eight standard load optic sensors may be connected to the monitor.

The monitor will work with any API 2 wire THERMISTOR probe. The monitor is optimally set up for use with GREEN thermistor, 200 ohm, type probes. It will also work with SILVER thermistor, 2,000 ohm, type probes, but the time to warm-up will take longer. The monitor will also work with any electronic type 2 wire probe that conforms to the API thermistor signal format. Civacon’s electronic 2 wire sensor is called a QUICK-START® sensor. Please refer to the factory for current model numbers and availability. Depending on the amount of channels the monitor is equipped with, the monitor can handle either six (6) or eight (8) probes.

The monitor is also designed to work with any onboard Monitor’s API OPTIC or APITHERMISTOR signal format outputs. Of course the monitor can only be connected to one type of signal source at any one time. The Civacon **OPTI-THERM® Model 8460SRC** replacement chassis is also equipped with ground verification circuitry compatible with systems manufactured by the Scully Signal Company. Upgrade of your existing system is possible following the instruction covered under the GROUND VERIFICATION section.

3. Installation Instructions

Step 1 Turn off Power supply to existing monitor.

It is important to be sure that all electrical power is disconnected (turned off) to the monitor before the explosion proof enclosure is opened. This is important to prevent fire or personal injury.

CAUTION:

Fire or electrical shock may result if power is not disconnected from the control monitor before the enclosure is opened. Ensure no cargo tanks or flammable material is present before starting work. All work should be performed by a competent electrician.

Step 2 Remove explosion proof enclosure bolts and open enclosure.

Using the correct tool, remove the bolts from the enclosure. Save these bolts for later re-assembly. Pull enclosure open.

Step 3 Make a drawing of the existing wiring connections.

On a piece of clean white paper make a drawing that identifies the wire connections and terminal numbers before any wire connections are removed. Make a drawing of the top and bottom terminal blocks. This drawing is important to ensure all field connections are returned to the correct terminal.

Step 4 Use a voltmeter to ensure power is disconnected.

Using a voltmeter, set on a scale suitable for measuring 120VAC, take a voltage reading on the top terminals marker HOT and NEUT. Do this by placing one of the test probes on each terminal. Next perform the same test on terminals NO, C, NC. Place one of the test leads on the explosion proof housing and the other on each terminal. In all tests the meter should read zero volts. If any voltage is detected, reexamine the power disconnect to ensure all power sources to the monitor are turned off.

Step 5 Remove wire connection from terminal blocks.

Using a flat blade screwdriver, loosen the terminal block screws and remove the wires from the terminal blocks. Do this on both the top and bottom terminal blocks. After the wires are removed bend them out of the way to make clearance for the chassis to be removed. Tagging and numbering the wires with tape will help in the identification when its time to reconnect the wires to the new chassis.

Step 6 Remove the four chassis mounting screws and remove the chassis.

Loosen and remove the four mounting screw which hold the chassis to the back of the explosion proof enclosure. If the screws are stuck do not break them off, use some type of penetrating oil to loosen the screws. After the screws are removed, pull the chassis from the explosion proof box. These items can be discarded.

Step 7 Install the 8460SRC assembly in the enclosure.

Using the four screws provided, mount the assembly to the rear of the enclosure.

Step 8 Turn off Power supply to existing monitor.

Using your previous drawings make the wiring connections to the top and bottom terminal blocks. The top terminal block is identical to the Scully terminal block so all wire connections should align with the correct terminal screws. Note: ST-6 power connection is marked L1 and L2 where the Biclops® model is marked NEUT and HOT. Scully Terminal convention L1 = NEUT and L2 = HOT. Civacon's wiring convention is L1 = HOT and L2 = NEUT.

Bottom terminal block connections vary between the ST-6 and Biclops® models. The terminal identification label on front of the **8460SRC** chassis has both ST-6 and Biclops® identification codes. Follow Figure 5 for additional wiring instructions. ST-6 wiring should re-connect directly to the existing terminal blocks without modification. Biclops® models with optic and thermistor plugs will require some change to wire connections.

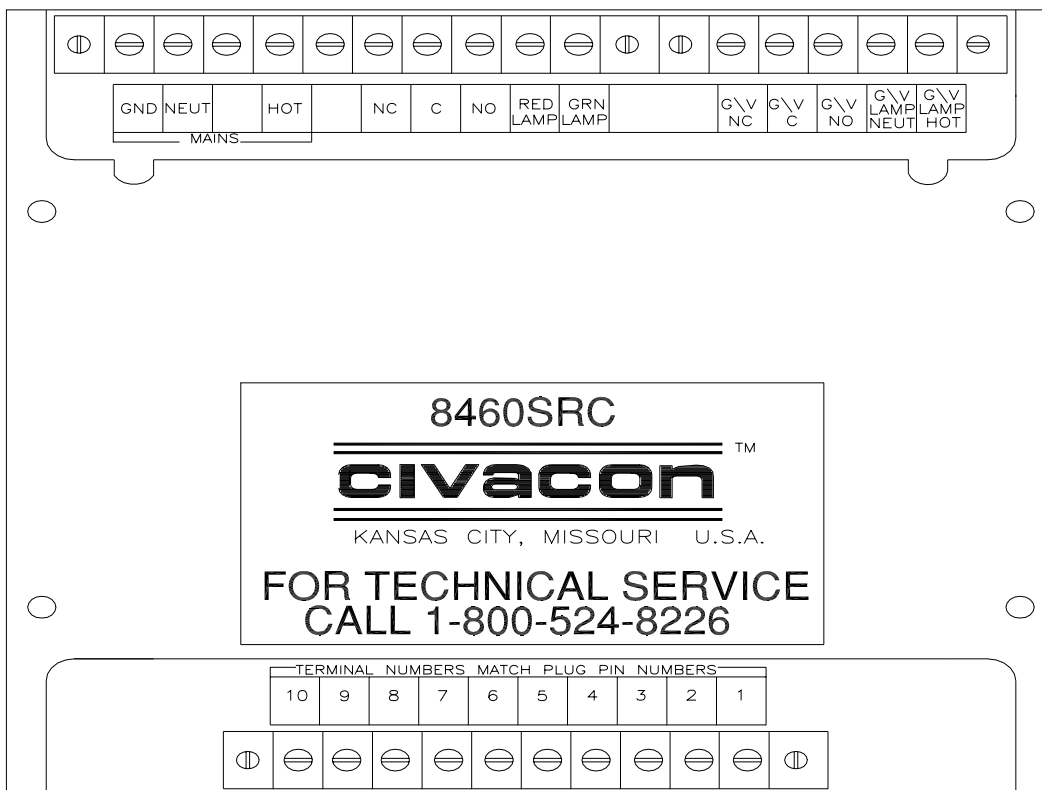

FIGURE 1 - Mechanical Assembly Drawing

Step 9 Replace schematic and enclosure labels.

Select the appropriate label from the set of labels supplied for the specific model of monitor you are working on. Remove the existing paper label from the inside enclosure cover and clean the surface. Place the new vinyl label on the inside of the enclosure cover in the same area as the old label. This label will show the proper wiring schematics for the **8460SRC** chassis of this enclosure. Discard unused labels. Close enclosure lid but do not install bolts.

The **8460SRC** kit contains two adhesive backed metal labels for the front cover of the enclosure. The metal labels differ by the configuration of the cut-outs for two different models. A label is provided for the ST-6 and Biclops® models. Please select the label that matches your model. Next remove the by-pass switch housing via the two screws located in the housing and remove the selector switch knob used on the Biclops® units. Clean the surface of the existing label on the monitor. Remove the paper backing of the selected metal label, being careful not to bend the label, and carefully place over the existing Scully nameplate. Burnish the new label into place before proceeding. After the label is firmly affixed to the enclosure cover, reinstall the by-pass switch housing and selector knob. Discard the unused label.

A second 3" x 4" nameplate is provided for the side of the enclosure. Again clean the existing label before removing the paper backing, and place this nameplate over the existing side nameplate. Burnish the new label into place before proceeding.

It is not necessary to remove the existing nameplates. The new labels are designed to fit over the existing nameplates.

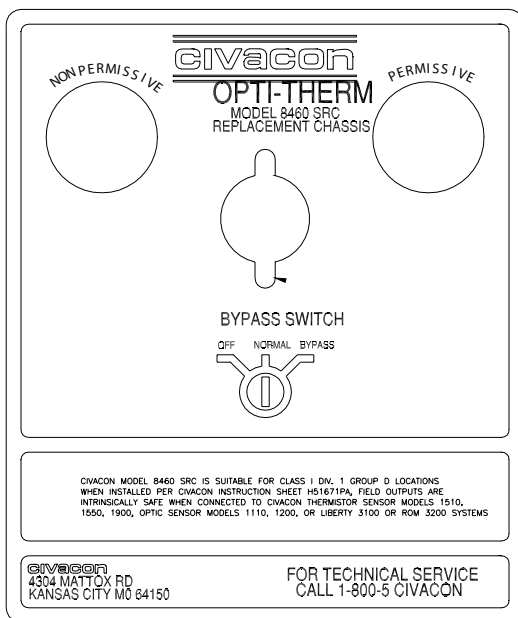

Replacement Label for Biclops®

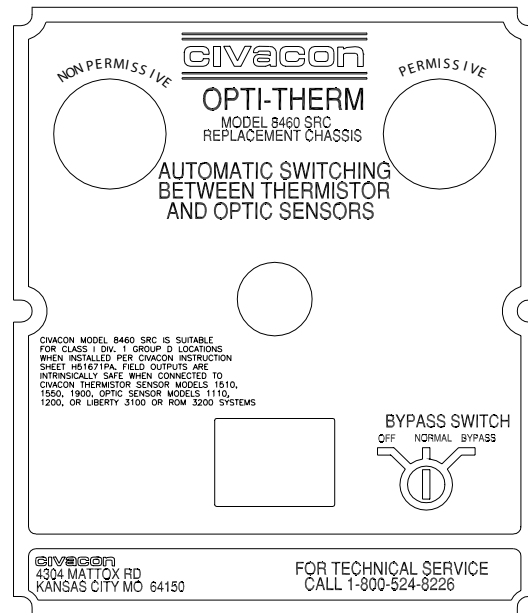

Replacement Label for ST-6

FIGURE 2 - Front Cover Labels for the Enclosure

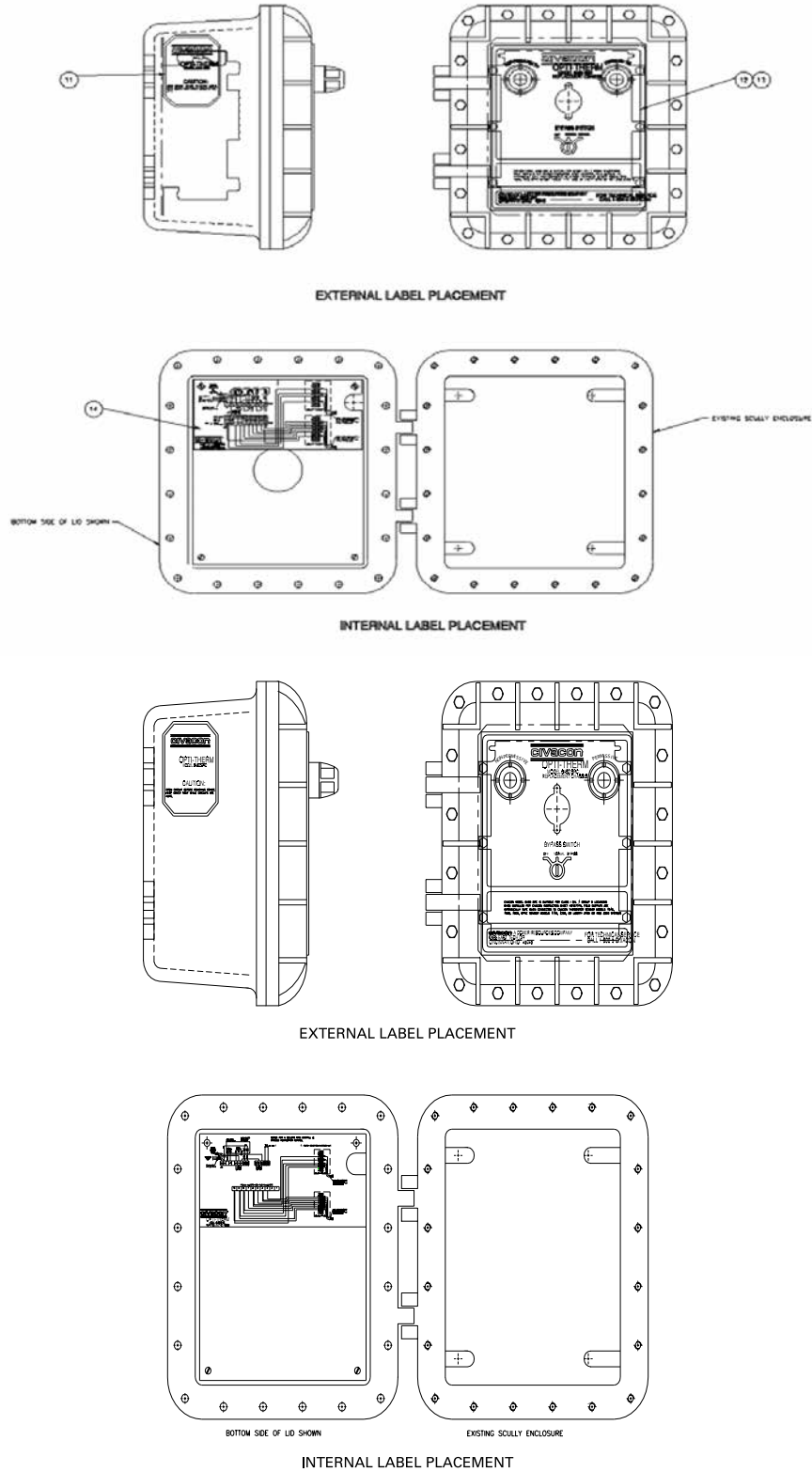

FIGURE 3 - Internal Replacement Labels

Step 10 Check all wire connections before re-connection of power.

Visually check the internal wiring connections before the power is reconnected to the monitor. If all wiring connections check out, replace the bolts in the enclosure. Then re-connect the power. After power is reconnected the RED indicating lamp on the front cover should be lit.

Using the Civacon Model 1386 OPTI-THERM, RACKTESTER , connect the API plug and cord to the 1386 RACKTESTER. The RED non-permissive light should go out and the GREEN permissive light should turn on. The permissive circuit to the automation system should be enabled.

CAUTION:

The control monitor's wiring and terminal strips on one side are intrinsically safe, and are separated from the AC power wiring by barriers. This separation of wires must be maintained. All sensor wires must enter the bottom (intrinsically safe side) of the monitor enclosure, and not mix with the AC power wiring or any other wiring at the top. AC power and control circuit wiring must enter through the conduit openings in the top of the enclosure. Wires should be cut to length with no excessive wire coiled inside the enclosure.

Installation of Civacon's 8460SRC Replacement Chassis Kit is now complete. For additional questions or support call the Civacon Technical Assistance Line at 1-800-5 CIVACON.

4. Ground Verification Wiring Installation

The Civacon Model 8460SRC replacement chassis is equipped with a ground verification circuit compatible with existing Scully systems. Figures 4 & 5 shows the location of terminal block which provides contacts for connection to terminal automation and a remote status lamp. Terminals marked G/V Lamp Hot have 120VAC contacts that allow connection of any 120VAC indicating lamp across these contacts.

Terminals marked G/V NC, G/V C, AND G/V NO are dry contacts to communicate status of the grounding circuit to the automation system. These contacts can provide individual ground and overfill status to the automation system or be wired in series with C and NC to provide a combined overfill and ground verification permissive to the automation system.

The terminal where plug connection are the same as the pin numbering. This terminal must be wired to pin 9 on each of the plugs connected to the monitor. Figures 4 & 5 show wiring of ground verification circuits. Trucks loading on this configuration must have pin 9 on their overfill sockets wired with a 12 gauge wire to the frame of the trailer. If Scully grounding bolts are already in use on the tank trailers, then no change is required. See Driver / Operator notice on Page 10.

Separate ground verification and overfill signaling can permit the automation system to differentiate between a connected plug and defective overfill system. Also the automation system would be able to detect if the plug is disconnected prior to printing the bill of lading thus permitting the truck to drive away.

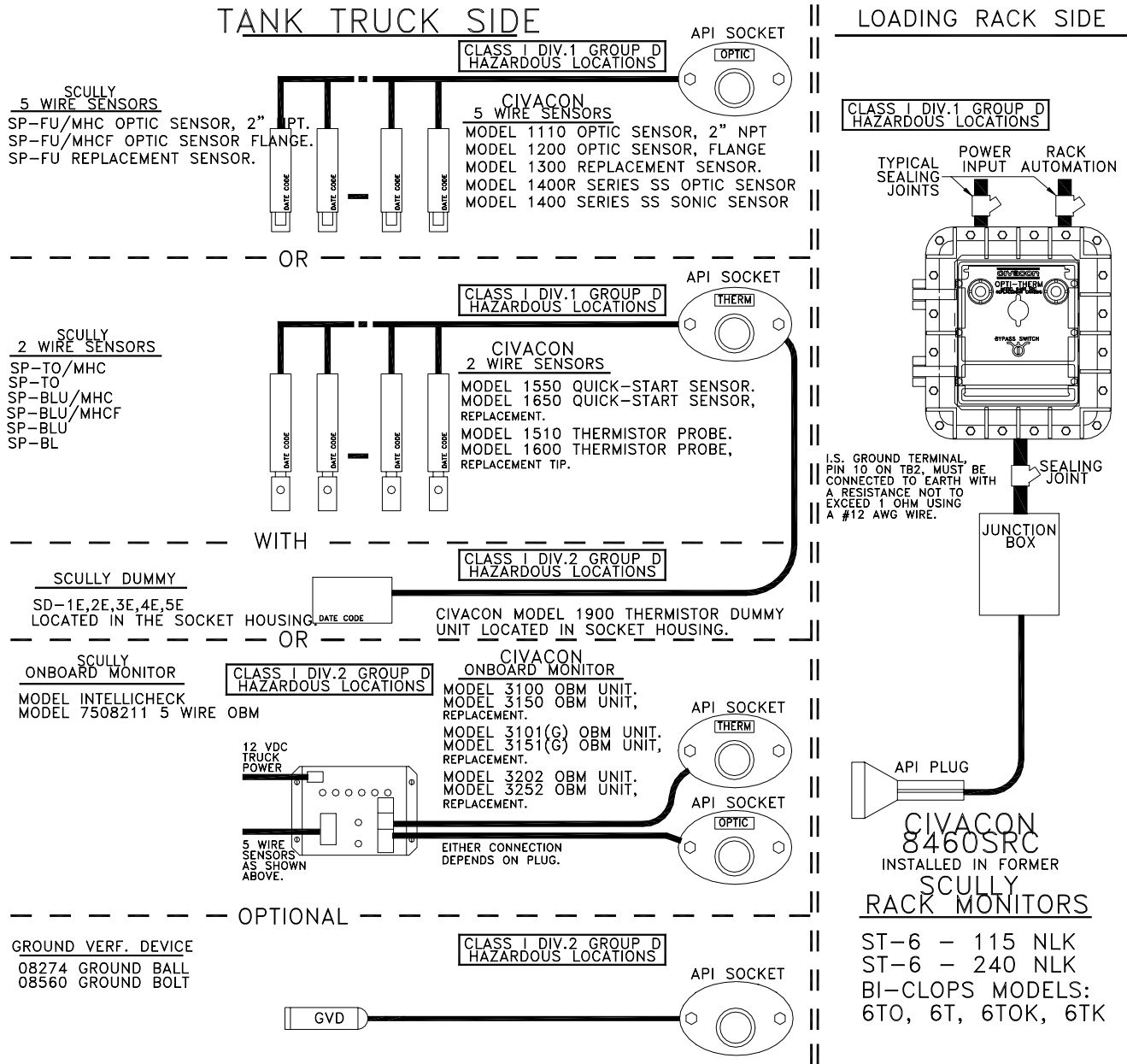
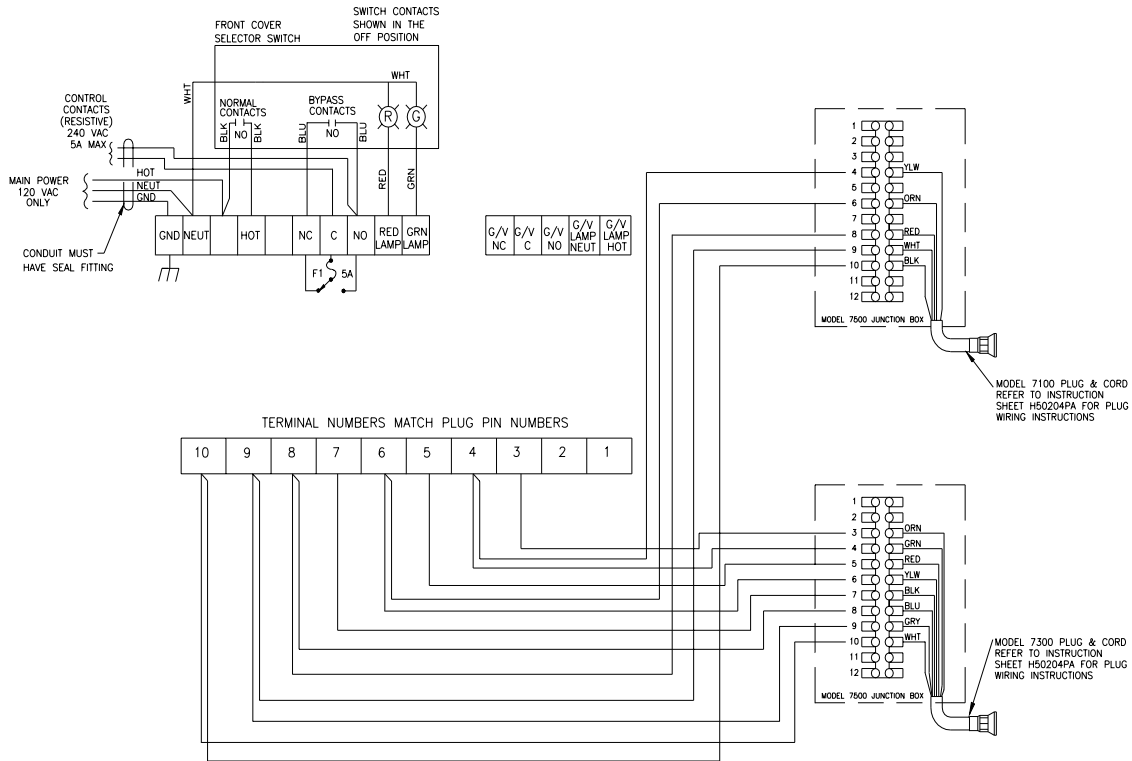

FIGURE 4 - System Control Diagram

Additional Notes:

- Control Equipment and Electrical apparatus connected to the Rack Monitor should not use or generate more than 250 volts.
- Installation should be in accordance with NEC ANSI/NFPA 70 and ANSI/ISA RP12.6 . In Canada, the system must be installed in accordance with the Canadian Electric Code, CEC Part I.
- Maximum ambient temperature is 60° C (140° F) .
- CIVACON sensor devices and monitors connected to the API sockets are shown on the diagram; plus special length versions of the same models of sensors with an "S" suffix.
- SCULLY sensor devices and monitors connected to the API sockets are shown on the diagram.

WIRING FOR REPLACING A BICLOPS.



WIRING FOR A BICLOPS WITH OVERFILL & GROUND VERIFICATION BYPASS.

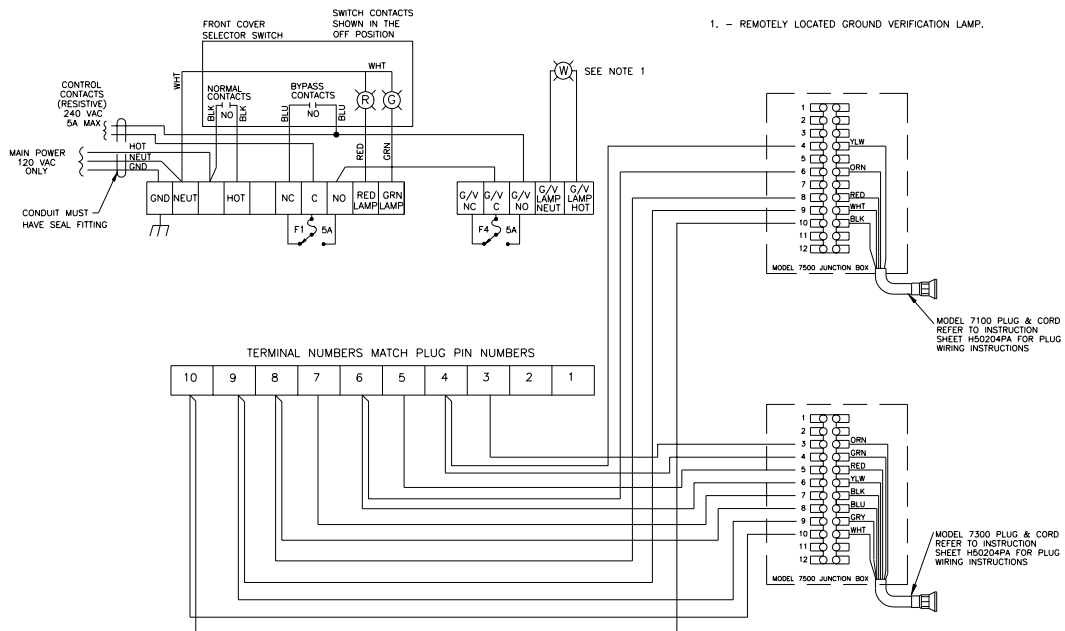
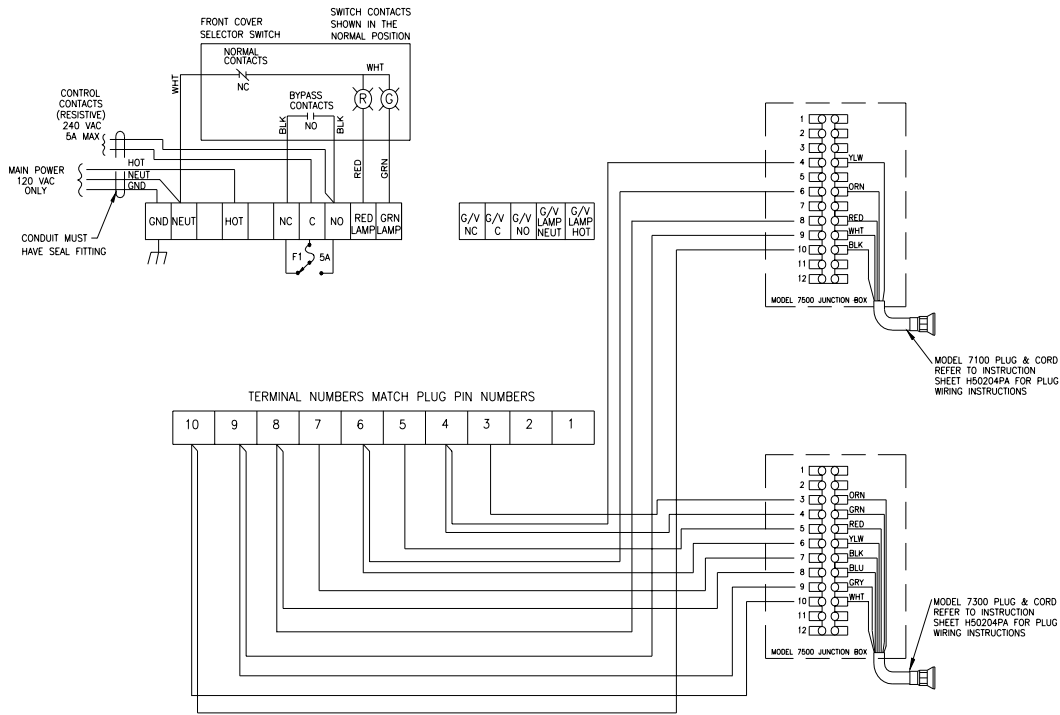

FIGURE 5 - Biclops® System Wiring

WIRING FOR REPLACING A ST-6.



WIRING FOR A ST-6 WITH OVERFILL & GROUND VERIFICATION BYPASS.

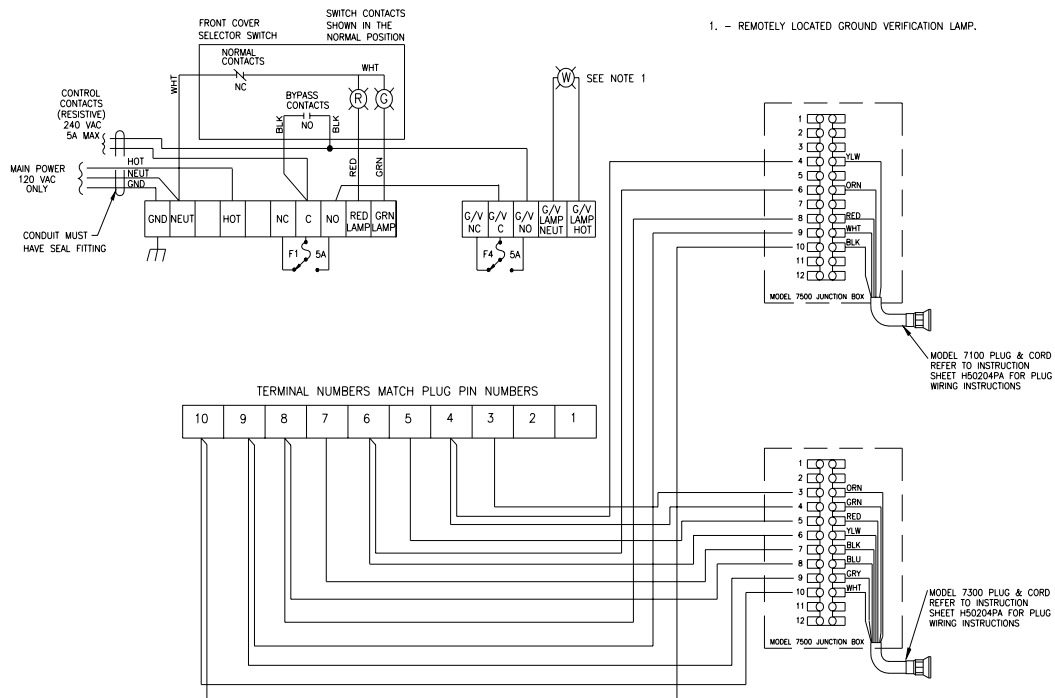

FIGURE 6 - ST-6 System Wiring

5. Power and Automation Connections

Three terminals are provided on the power input terminal strip on the monitor. These are HOT, NEUTRAL, and GROUND. The proper power source (120VAC) must be wired to these terminals including a Green ground wire.

Three terminals are provided for the control channel output on the monitor. These are C(COMMON), NC (NORMALLY CLOSED), and NO (NORMALLY OPEN), Form C type contacts for the overfill permissive signal and G/V NC (NORMALLY CLOSED), G/V C (COMMON), and G/V NO (NORMALLY OPEN), FORM C type contacts for the Ground Verification Permissive. The proper control signal source must be wired to these terminals. It is suggested that the control signal source be wired into the C (COMMON) terminal, as it is the fused input control terminal.

The wiring going to the controlled device should then be connected to the contact of the terminal strip. Contacts C are fused at 5 Amps. These are panel mounted fuses located on the main PCB inside the **8460SRC** chassis. See Figures 4 and 5 for wiring drawings.

6. Checkout Procedure

For **8460SRC** replacement chassis kit checkout procedure.

Step 1 Before applying AC line power to the 8460SRC, perform a visual inspection of the power and control wiring according to Figures 4 & 5.

Step 2 Apply the proper AC line power to the 8460SRC Monitor. Ensure the rack monitor's plug(s) is not connected to anything. The RED indicator on the Rack Monitor should light. Check the rack automation equipment for a NO "PERMISSIVE" signal.

NOTE: The Bypass switch should NOT be turned. Turn the switch to NORMAL.

Step 3 Connect the Rack Monitor's plug to an appropriate test sensor source.

NOTE: Use a known working tank truck with appropriate sensors installed that can connect through the plug and socket to the Rack Monitor for a permit signal source. A Civacon Model 1386 RacTestert may be used if it is available.

The GREEN indicator on the "front enclosure lid" should light. The RED indicator should go out.

Check the rack automation equipment for a "PERMISSIVE" signal.

Step 4 Disconnect the appropriate test sensor permit source. The RED indicator should be ON. The GREEN indicator should extinguish appropriately.

Step 5 Turn the Bypass switch to the "BY-PASS" position. The GREEN and RED indicators should both be ON.

Step 6 Turn the key on the Bypass switch to the "OFF" position.

Step 7 The RED and GREEN indicator should now be OFF.

- Step 8** Troubleshoot any problems if the monitor's operation is not as stated above. There are NO field adjustments required on this PCB. Do not disturb the factory settings of the adjustment pots. Please consult the factory for any advice.

CAUTION:

The monitor chassis contains NO components that are field replaceable except the four (4) AC fuses. Any substitution of components may impair the intrinsic safety and approvals of the system.

SAFETY FIRST!!

POWER MUST BE OFF WHEN REMOVING AND REPLACING THE AC FUSES IN THE MONITOR. THE WIRES FOR THE POWER TERMINALS FROM THE POWER PANEL MUST BE KEPT TURNED OFF DURING ANY FUSE REPLACEMENT! This is important to maintain safe repair practices.

The four (4) AC fuses that are field replaceable are F1, F2, F3, F4, & F6. The following list of specifications should be followed:

F1 = 3AG Type, 250V, 5 AMP; For control relay common C1- Permit.

F2 = 3AG Type, 250V, ¼ AMP, SLO-BLOW; For AC line input, L2 terminal; By-passed in 120VAC applications.

F3 = 3AG Type, 250V, ¼ AMP, SLO-BLOW; For AC line input, L1 terminal.

F4 = 3AG Type, 250V, 5 AMP; For control relay common C2 - Ground verification.

F6 = 3AG Type, 250V, 1 AMP; For light control common. Internally connected to the line voltage, L1.

Please note that fuse F5 is **NOT** a field replaceable component. Follow the CAUTION statement above.

Notes

7. Warranty

All parts and products are thoroughly inspected and tested from the time raw material is received at our plant, until the product is completed. We guarantee that all products are free from defects in materials and workmanship for a period of one year from the date of shipment. Any product that may prove defective within said one year period will, at our option, be promptly repaired, or replaced, or credit given for future orders.

This warranty shall not apply to any product that has been altered in any way, which has been repaired by any party other than an authorized service representative, or when such a failure is due to misuse or conditions of use. We shall have no liability for labor costs, freight costs, or any other cost or charges in excess of the amount of invoice for the products.

THIS WARRANTY IS IN LIEU OF ALL OTHER WARRANTIES, EXPRESS OR IMPLIED, AND SPECIFICALLY THE WARRANTIES OF MERCHANTABILITY AND FITNESS FOR A PARTICULAR PURPOSE.

WARNING:

OPW Engineered Systems' products should be used in compliance with applicable federal, state, and local laws and regulations. Product selection should be based on physical specifications and limitations, compatibility with the environment, and the material to be handled. OPW Engineered Systems makes no warranty of fitness for a particular use.

IMPORTANT: OPW products should be used in compliance with applicable federal, state, provincial, and local laws and regulations. Product selection should be based on physical specifications and limitations and compatibility with the environment and materials to be handled. OPW MAKES NO WARRANTY OF FITNESS FOR A PARTICULAR USE. All illustrations and specifications in this literature are based on the latest product information available at the time of publication. OPW reserves the right to make changes at any time in prices, materials, specifications and models and to discontinue models without notice or obligation.