



## OPTIFLUX 2000 Technical Datasheet

### Electromagnetic flow sensor

- For all water and wastewater applications
- Wide range of approvals for potable water
- Robust, fully welded construction



The documentation is only complete when used in combination with the relevant documentation for the signal converter.

1	Product features	3
1.1	Reliable solution for the water and wastewater industry	3
1.2	Options	5
1.3	Measuring principle	7
2	Technical data	8
2.1	Technical data	8
2.2	Legal metrology	14
2.2.1	OIML R49	14
2.2.2	MID Annex MI-001	16
2.3	Measuring accuracy	19
2.4	Pressure derating	20
2.5	Vacuum load	23
2.6	Dimensions and weights	24
3	Installation	27
3.1	Intended use	27
3.2	General notes on installation	27
3.2.1	Vibration	27
3.2.2	Magnetic field	27
3.3	Installation conditions	28
3.3.1	Inlet and outlet	28
3.3.2	Bends in 2 or 3 dimensions	28
3.3.3	T-section	28
3.3.4	Bends	29
3.3.5	Open feed or discharge	29
3.3.6	Flange deviation	30
3.3.7	Pump	30
3.3.8	Control valve	30
3.3.9	Air venting and vacuum forces	31
3.3.10	Mounting position	32
3.4	Mounting	32
3.4.1	Torques and pressures	32
4	Electrical connections	35
4.1	Safety instructions	35
4.2	Grounding	35
4.3	Virtual reference for IFC 300 (C, W and F version)	37
4.4	Connection diagrams	37
5	Notes	38

## 1.1 Reliable solution for the water and wastewater industry

The **OPTIFLUX 2000** is designed to meet the demands for all water and waste water applications including groundwater, potable water, waste water, sludge and sewage, industry water and salt water.

The OPTIFLUX 2000 has a field proven and unsurpassed lifetime. This is assured by the fully welded construction, full bore pipe, absence of moving parts and wear resistant liner materials. The sensor has the widest diameter range available in the market: from DN25 up to DN3000.



- ① Robust fully welded construction
- ② Diameter range: DN25...DN3000
- ③ PP, PO and hard rubber liners

### Highlights

- Rugged liners suitable for any water and wastewater application
- Proven and unsurpassed lifetime, huge installed base
- Tamper proof, fully welded construction, also available in customer specific constructions
- Drinking water approvals including KTW, KIWA, ACS, DVGW, NSF, WRAS
- Suitable for subsoil installation and constant flooding (IP68)
- Bi-directional flow metering
- Compliant with requirements for custody transfer (MID MI-001, OIML R49, ISO 4064, EN 14154)
- Standard in house wet calibration of sensors up to diameter DN3000
- Easy installation and commissioning
- No grounding rings with virtual reference option on IFC 300
- In-situ verification with OPTICHECK
- Extensive diagnostic capabilities
- Maintenance-free

### Industries

- Water
- Wastewater
- Pulp & Paper
- Minerals & Mining
- Iron, Steel & Metals
- Power

### Applications

- Water abstraction
- Water purification and desalination
- Drinking water distribution networks
- Revenue metering or billing
- Leakage detection
- Irrigation
- Industry water
- Cooling water
- Wastewater
- Sewage and sludge
- Sea water

## 1.2 Options

The reliable solution for the water and wastewater industry



### From standard to customized

For easy ordering the standard range of the OPTIFLUX 2000F covers all popular sizes, flange materials and connections (ASME, EN, JIS, AWWA). But KROHNE does not stop here. Our extensive engineering department is dedicated to provide solutions for all specifications not covered by our standard range. Requests for special sizes, flange connections, pressure ratings, building lengths, and materials, will always get a serious review. Whenever possible we will engineer a flow meter that fits your application.



### Easy installation

Fitting the OPTIFLUX 2000 is easy with the flanged design and standard ISO insertion lengths. To further ease the operation, the OPTIFLUX 2000 can be installed without filters and straighteners. Even grounding rings are not required with the patented "Virtual Reference" option on the IFC 300 converter.



### IP68

Installation in measurement chambers subject to (constant) flooding is possible with the IP68 rated version. The chambers can even be completely surpassed if the IP68 version is combined with our special subsoil coating, allowing the OPTIFLUX 2000 to be installed directly in the ground.



**Custody transfer**

In combination with the IFC 300 converter the OPTIFLUX 2000 is suitable for custody transfer applications. It meets the requirements of OIML R49 and can be verified according to Annex MI-001 of the Measuring Instruments Directive (MID)

All water meters for legal metrology purposes in Europe require certification under the MID. The EC type examination certificate for the OPTIFLUX 2300 is valid for the compact and the remote version and applies for forward and reverse flow.

### 1.3 Measuring principle

An electrically conductive fluid flows inside an electrically insulated pipe through a magnetic field. This magnetic field is generated by a current, flowing through a pair of field coils. Inside of the fluid, a voltage  $U$  is generated:

$$U = v * k * B * D$$

in which:

$v$  = mean flow velocity

$k$  = factor correcting for geometry

$B$  = magnetic field strength

$D$  = inner diameter of flow meter

The signal voltage  $U$  is picked off by electrodes and is proportional to the mean flow velocity  $v$  and thus the flow rate  $q$ . A signal converter is used to amplify the signal voltage, filter it and convert it into signals for totalising, recording and output processing.

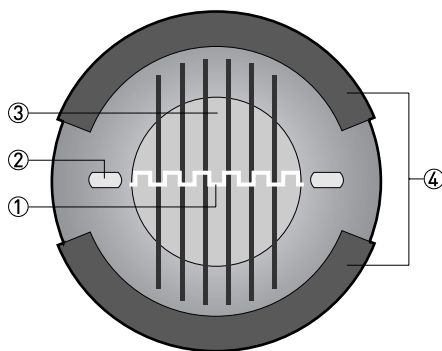

Figure 1-1: Measuring principle

- ① Induced voltage (proportional to flow velocity)
- ② Electrodes
- ③ Magnetic field
- ④ Field coils

## 2.1 Technical data

- *The following data is provided for general applications. If you require data that is more relevant to your specific application, please contact us or your local sales office.*
- *Additional information (certificates, special tools, software,...) and complete product documentation can be downloaded free of charge from the website (Download Center).*

### Measuring system

Measuring principle	Faraday's law of induction
Application range	Electrically conductive fluids
<b>Measured value</b>	
Primary measured value	Flow velocity
Secondary measured value	Volume flow

### Design

Features	Fully welded maintenance-free sensor.
	Large diameter range DN25...3000
	Rugged liners approved for drinking water.
	Large standard range but also available in customer specific diameter, length and pressure rating.
Modular construction	The measurement system consists of a flow sensor and a signal converter. It is available as compact and as separate version. Additional information can be found in the documentation of the signal converter.
Compact version	With IFC 050 converter: OPTIFLUX 2050 C
	With IFC 100 converter: OPTIFLUX 2100 C
	With IFC 300 converter: OPTIFLUX 2300 C
Remote version	In wall (W) mount version with IFC 050 converter: OPTIFLUX 2050 W
	In wall (W) mount version with IFC 100 converter: OPTIFLUX 2100 W
	In field (F), wall (W) or rack (R) mount version with IFC 300 converter: OPTIFLUX 2300 F, W or R
Nominal diameter	With IFC 050 converter: DN25...1200 / 1...48"
	With IFC 100 converter: DN25...1200 / 1...48"
	With IFC 300 converter: DN25...3000 / 1...120"



## Measuring accuracy

Reference conditions	Medium: water	
	Temperature: +10...+30°C / +50...+86°F	
	Operating pressure: 1 bar / 14.5 psi	
	Inlet section $\geq$ 5 DN	
	Electrical conductivity: $\geq$ 300 $\mu$ S/cm	
Maximum measuring error	IFC 050: 0.5% of the measured value above 0.5 m/s; below 0.5 m/s, deviation $\pm$ 2.5 mm/s	
	IFC 100: down to 0.3% of the measured value $\pm$ 1 mm/s	
	IFC 300: down to 0.2% of the measured value $\pm$ 1 mm/s	
	The maximum measuring error depends on the installation conditions.	
	For detailed information refer to <i>Measuring accuracy</i> on page 19.	
Repeatability	$\pm$ 0.1% of the measured value, minimum 1 mm/s	
Calibration / Verification	<b>Standard:</b>	
	2 point calibration by a direct volume comparison.	
	<b>Optional:</b>	
	Verification to Measurement Instrument Directive (MID), Annex MI-001. Standard: Verification at Ratio (Q3/Q1) = 80, Q3 $\geq$ 2 m/s Optional: Verification at Ratio (Q3/Q1) > 80 on request	
MID Annex MI-001 (Directive 2004/22/EC)	Only in combination with the IFC 300 signal converter.	
	Diameter range: DN25...1600	
	Forward and reverse (bi-directional) flow	
	Liquid temperature range: +0.1°C / 50°C	
	For detailed information refer to <i>Legal metrology</i> on page 14.	
	<b>EC-Type examination certificate to MID Annex MI-001</b>	
OIML R49	Only in combination with the IFC 300 signal converter.	
	Diameter range	Class 1: DN65...1600
		Class 2: DN25...50
	Forward and reverse (bi-directional) flow	
	Liquid temperature range: +0.1°C / 50°C	
	For detailed information refer to <i>Legal metrology</i> on page 14.	

## Operating conditions

<b>Temperature</b>	
For detailed information in pressure / temperature refer to <i>Pressure derating</i> on page 20	
	For Ex versions different temperatures are valid. Please refer to the relevant Ex documentation for details.
Process temperature	Hard rubber liner: -5...+80°C / 23...+176°F
	Polypropylene liner: -5...+90°C / 23...+194°F
	Polyolefin liner: -5...+80°C / 23...+176°F
Ambient temperature	<b>Standard</b> (with aluminium converter housing): standard flanges: -20...+65°C / -4 ...+149°F
	<b>Option</b> (with aluminium converter housing): low temperature carbon steel flanges or stainless steel flanges -40...+65°C / -40...+149°F
	<b>Option</b> (with stainless steel converter housing): low temperature carbon steel flanges or stainless steel flanges -40...+55°C / -40...+130°F
	Protect electronics against self-heating at ambient temperatures above +55°C / +131°F.
Storage temperature	-50...+70°C / -58...+158°F
<b>Measurement range</b>	-12...+12 m/s / -40...+40 ft/s
<b>Pressure</b>	
For detailed information in pressure / temperature refer to <i>Pressure derating</i> on page 20	
EN 1092-1	DN2200...3000: PN 2.5
	DN1200...2000: PN 6
	DN200...1000: PN 10
	DN65 and DN100...150: PN 16
	DN25...50 and DN80: PN 40
	Other pressures on request
ASME B16.5	1...24": 150 & 300 lb RF
	Other pressures on request
JIS	DN50...1000 / 2...40": 10 K
	DN25...40 / 1...1½": 20 K
	Other pressures on request
AWWA (class B or D FF)	<b>Option:</b> DN700...1000 / 28...40": ≤ 10 bar / 145 psi
	DN1200...2000 / 48...80": ≤ 6 bar / 87 psi
DIN	PN16 - 6 bar rated; DN700...2000
	PN10 - 6 bar rated; DN700...2000
	PN6 - 2 bar rated; DN700...2000
Vacuum load	For detailed information refer to <i>Vacuum load</i> on page 23.
Pressure loss	Negligible

Chemical properties	
Physical condition	Electrically conductive liquids
Electrical conductivity	Standard: $\geq 5 \mu\text{S}/\text{cm}$
	Demineralized water: $\geq 20 \mu\text{S}/\text{cm}$
Permissible gas content (volume)	IFC 050: $\leq 3\%$
	IFC 100: $\leq 3\%$
	IFC 300: $\leq 5\%$
Permissible solid content (volume)	IFC 050: $\leq 10\%$
	IFC 100: $\leq 10\%$
	IFC 300: $\leq 70\%$

### Installation conditions

Installation	Assure that the flow sensor is always fully filled.
	For detailed information refer to <i>Installation</i> on page 27.
Flow direction	Forward and reverse
	Arrow on flow sensor indicates flow direction.
Inlet run	$\geq 5 \text{ DN}$
Outlet run	$\geq 2 \text{ DN}$
Dimensions and weights	For detailed information refer to <i>Dimensions and weights</i> on page 24.

### Materials

Sensor housing	Sheet steel
	Other materials on request
Measuring tube	Austenitic stainless steel
Flanges	Carbon steel
	Other materials on request
Liner	<b>Standard:</b>
	DN25...150 / 1...6": polypropylene
	DN200...3000 / 8...120": hard rubber
	<b>Option:</b>
	DN25...150 / 1...6": hard rubber
	DN200...1000 / 8...40": polyolefin
Protective coating	On exterior of the meter: flanges, housing, signal converter (compact version) and / or connection box (field version)
	Standard: polyurethane coating
	Option: subsoil coating, offshore coating
Connection box	Only for remote versions
	Standard: die-cast aluminium
	Option: stainless steel
Measuring electrodes	Standard: Hastelloy <sup>®</sup> C
	Option: stainless steel, titanium
	Other materials on request

Grounding rings	Standard: stainless steel
	Option: Hastelloy® C, titanium, tantalum
	Grounding rings can be omitted with virtual reference option for the IFC 300 signal converter.
Reference electrode (optional)	Standard: Hastelloy® C
	Option: stainless steel, titanium
	Other materials on request

### Process connections

<b>Flange</b>	
EN 1092-1	DN25...3000 in PN 2.5...40
ASME	1...24" in 150 & 300 lb RF
JIS	DN25...1000 in 10...20 K
AWWA	DN700...2000 in 6...10 bar
Design of gasket surface	RF
	Other sizes or pressure ratings on request.

### Electrical connections

	For full detail; see the relevant documentation of the signal converter
<b>Signal cable</b> (remote versions only)	
Type A (DS)	<b>In combination with the IFC 050, IFC 100 and IFC 300 signal converter</b> Standard cable, double shielded. Max. length: 600 m / 1950 ft (depends on electrical conductivity and measuring sensor)
Type B (BTS)	<b>Only in combination with the IFC 300 signal converter</b> Optional cable, triple shielded. Max. length: 600 m / 1950 ft (depends on electrical conductivity and measuring sensor)
I/O	For full details of I/O options, including data streams and protocols, see technical datasheet of the relevant signal converter.

### Approvals and certificates

<b>CE</b>	
	This device fulfils the statutory requirements of the EC directives. The manufacturer certifies successful testing of the product by applying the CE mark.
Electromagnetic compatibility	Directive: 2004/108/EC, NAMUR NE21/04
	Harmonized standard: EN 61326-1 : 2006
Low voltage directive	Directive: 2006/95/EC
	Harmonized standard: EN 61010 : 2010
Pressure equipment directive	Directive: 97/23/EC
	Category I, II, III or SEP
	Fluid group 1
	Production module H

<b>Hazardous areas</b>	
ATEX	Please check the relevant Ex documentation for details.
	<b>Compact version with IFC 100 signal converter</b>
	II 2 GD
	<b>Compact version with IFC 300 signal converter</b>
	II 2 GD or II 2(1) GD
	<b>Remote version</b>
	II 2 GD
FM	<b>In combination with IFC 300 signal converter</b>
	Class I, Div. 2, Groups A, B, C and D
	Class II, Div. 2, Groups F and G
	Class III, Div. 2, Groups F and G
CSA	<b>In combination with IFC 300 signal converter</b>
	Class I, Div. 2, Groups A, B, C and D
	Class II, Div. 2, Groups F and G
NEPSI	GYJ05234 / GYJ05237
	Ex me ia IIC T6...T3
	Ex de ia II T6...T3
	Ex qe ia IIC T6...T3
	Ex e ia IIC T6...T3
<b>Other approvals and standards</b>	
Custody transfer	Only in combination with the IFC 300 signal converter.
	MID Annex MI-001 type examination certificate
	OIML R49 certificate of conformity
	Conformity with ISO 4064 and EN 14154
Drinking water approvals	Hard rubber liner: NSF / ANSI standard 61 / ACS, KTW (<60°C), DVGW-W270, KIWA on request.
	Polypropylene liner: ACS, KIWA, KTW, NSF / ANSI standard 61, WRAS
	Polyolefin liner: ACS, KTW (<60°C), DVGW-W270, WRAS
Protection category acc. to IEC 529 / EN 60529	<b>Standard:</b>
	IP66 / 67 (NEMA 4/4X/6)
	<b>Option:</b>
	IP68 (NEMA 6P)
	IP68 is only available for separate design and with a stainless steel connection box.
Shock test	IEC 68-2-27
	30 g for 18 ms
Vibration test	IEC 68-2-64
	f = 20 - 2000 Hz, rms = 4.5 g, t = 30 min.

## 2.2 Legal metrology

*OIML R49 and MID Annex MI-001 is **only** available in combination with the IFC 300 signal converter!*

### 2.2.1 OIML R49

The OPTIFLUX 2300 has a certificate of conformity with the international recommendation OIML R49. The certificate has been issued by NMI (Dutch board of weight and measures). The OIML R49 recommendation (2006) concerns water meters intended for the metering of cold potable and hot water. The measuring range of the flowmeter is determined by Q3 (nominal flow rate) and R (ratio).

The OPTIFLUX 2300 meets the requirements for water meters of accuracy class 1 and 2.

- For accuracy class 1, the maximum permissible error for water meters is  $\pm 1\%$  for the upper flow rate zone and  $\pm 3\%$  for the lower flow rate zones.
- For accuracy class 2, the maximum permissible error for water meters is  $\pm 2\%$  for the upper flow rate zone and  $\pm 5\%$  for the lower flow rate zones.

According to OIML R49, accuracy class 1 designation shall be applied only to flowmeter with  $Q_3 \geq 100 \text{ m}^3/\text{h}$ .

$$Q_1 = Q_3 / R$$

$$Q_2 = Q_1 * 1.6$$

$$Q_3 = Q_1 * R$$

$$Q_4 = Q_3 * 1.25$$

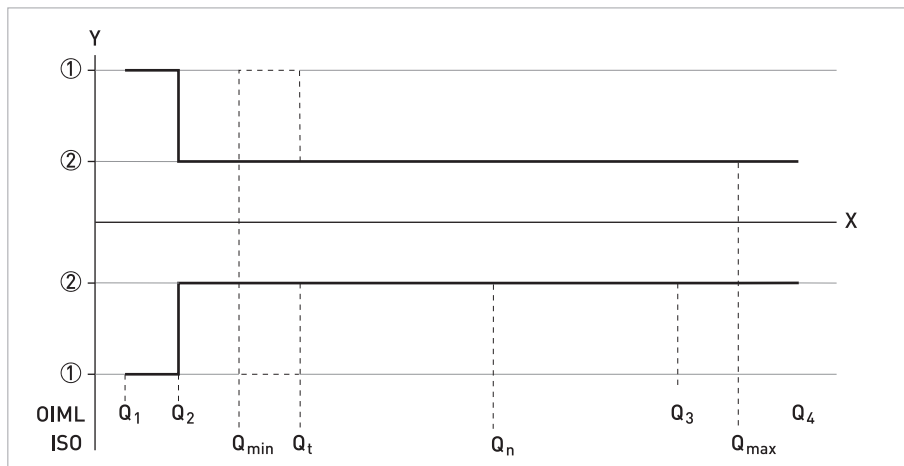

Figure 2-1: ISO flow rates added to figure as comparison towards OIML

**X:** Flow rate

**Y [%]:** Maximum measuring error

①  $\pm 3\%$  for class 1,  $\pm 5\%$  for class 2 devices

②  $\pm 1\%$  for class 1,  $\pm 2\%$  for class 2 devices

## OIML R49 Class 1

DN	Span (R)	Flow rate [m <sup>3</sup> /h]			
		Minimum Q1	Transitional Q2	Permanent Q3	Overload Q4
65	630	0.1587	0.25	100	125
80	630	0.254	0.40	160	200
100	630	0.3968	0.6	250	312.5
125	630	0.6349	1.0	400	500
150	630	0.6349	1.0	400	500
200	1000	1.0	1.6	1000	1250
250	1000	1.6	2.6	1600	2000
300	1000	2.5	4.0	2500	3125
350	500	5.0	8.0	2500	3125
400	500	8.0	12.8	4000	5000
450	500	8.0	12.8	4000	5000
500	500	12.6	20.2	6300	7875
600	160	39.375	63	6300	7875
700	80	125	200	10000	12500
800	80	125	200	10000	12500
900	80	200	320	16000	20000
1000	80	200	320	16000	20000
1200	80	200	320	16000	20000
1600	80	312.5	500	25000	31250

## OIML R49 Class 2

DN	Span (R)	Flow rate [m <sup>3</sup> /h]			
		Minimum Q1	Transitional Q2	Permanent Q3	Overload Q4
25	400	0.040	0.064	16	20
32	400	0.0625	0.10	25	31.3
40	400	0.0625	0.10	25	31.3
50	400	0.10	0.16	40	50

For DN65 to DN1600; same values (DN, R, Q1, Q2, Q3, Q4) as for OIML R49 class 1 are applicable.

### 2.2.2 MID Annex MI-001

All new designs of water meters that are to be used for legal purposes in Europe require certification under the Measurement Instrument Directive (MID) 2004/22/EC.

Annex MI-001 of the MID applies to water meters intended for the measurement of volume of clean, cold or heated water in residential, commercial and light industrial use. An EC-type examination certificate is valid in all countries of the European Union.

The OPTIFLUX 2300 has an EC-type examination certificate and can be verified to the MID Annex MI-001 for water meters with diameter DN25...DN1600. The conformity assessment procedure followed for OPTIFLUX 2300 is Module B (Type Examination) and Module D (Quality Assurance of the Production Process).

The maximum permissible error on volumes delivered between Q2 (transitional) flow rate and Q4 (overload) flow rate is  $\pm 2\%$ .

The maximum permissible error on volumes delivered between Q1 (minimum) flow rate and Q2 (transitional) flow rate is  $\pm 5\%$ .

$$Q1 = Q3 / R$$

$$Q2 = Q1 * 1.6$$

$$Q3 = Q1 * R$$

$$Q4 = Q3 * 1.25$$

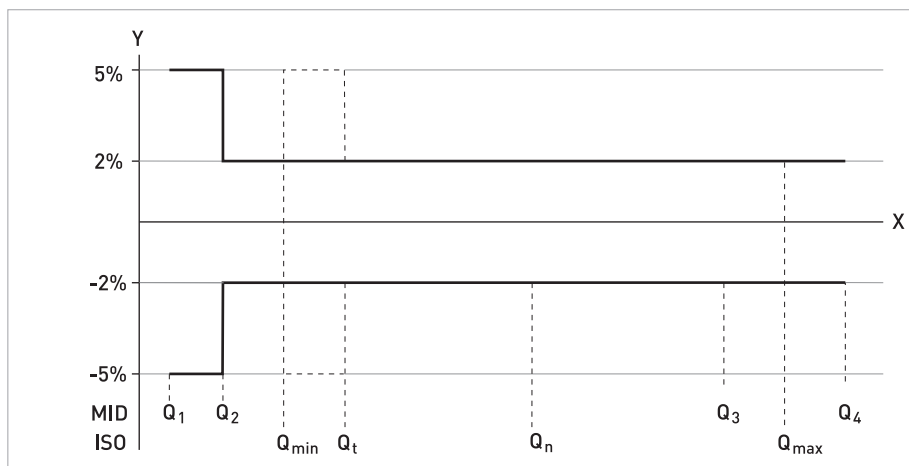

Figure 2-2: ISO flow rates added to figure as comparison towards MID

X: Flow rate

Y [%]: Maximum measuring error



## MI-001 certified flow characteristics

DN	Span (R) Q3 / Q1	Flow rate [m <sup>3</sup> /h]			
		Minimum Q1	Transitional Q2	Permanent Q3	Overload Q4
25	400	0.040	0.064	16	20
32	400	0.0625	0.10	25	31.3
40	400	0.0625	0.10	25	31.3
50	400	0.10	0.16	40	50
65	625	0.1587	0.25	100	125
80	640	0.254	0.40	160	200
100	625	0.3968	0.6	250	312.5
125	667	0.6349	1.0	400	500
150	667	0.6349	1.0	400	500
200	1000	1.0	1.6	1000	1250
250	1000	1.6	2.6	1600	2000
300	1000	2.5	4.0	2500	3125
350	500	5.0	8.0	2500	3125
400	500	8.0	12.8	4000	5000
450	500	8.0	12.8	4000	5000
500	500	12.6	20.2	6300	7875
600	160	39.375	63	6300	7875
700	80	125	200	10000	12500
800	80	125	200	10000	12500
900	80	200	320	16000	20000
1000	80	200	320	16000	20000
1200	80	200	320	16000	20000
1600	80	312.5	500	25000	31250

Verification to MI-001 and to OIML R49 class 2 is carried out at the following values for R, Q1, Q2 and Q3.

Verification to OIML R49 class 1 and at other values for R and Q3 available on request.

#### Verification to MI-001

DN	Span (R) Q3 / Q1	Flow rate [m <sup>3</sup> /h]		
		Q1	Q2	Q3
25	80	0.05	0.08	4
32	80	0.125	0.20	10
40	80	0.125	0.20	10
50	80	0.2	0.32	16
65	80	0.3125	0.50	25
80	80	0.5	0.80	40
100	80	0.7875	1.26	63
125	80	1.250	2.00	100
150	80	2.0	3.2	160
200	80	3.125	5.0	250
250	80	5.0	8.0	400
350	80	5.0	8.0	400
300	80	7.875	12.6	630
350	80	12.5	20.0	1000
400	80	12.5	20.0	1000
450	80	12.5	20	1000
500	80	20.0	32	1600
600	80	50.0	80	4000
700	80	125	200	10000
800	80	125	200	10000
900	80	200	320	16000
1000	80	200	320	16000
1200	80	200	320	16000
1600	80	312.5	500	25000

## 2.3 Measuring accuracy

Each flowmeter is standard wet calibrated under reference conditions by direct volume comparison. The performance of the flowmeter is defined and documented in an individual calibration certificate.

### Reference conditions

- Medium: water
- Temperature: +10...30°C / +50...86°F
- Operating pressure: 1 bar / 14.5 psi
- Inlet section:  $\geq 5$  DN
- Electrical conductivity:  $\geq 300 \mu\text{S/cm}$

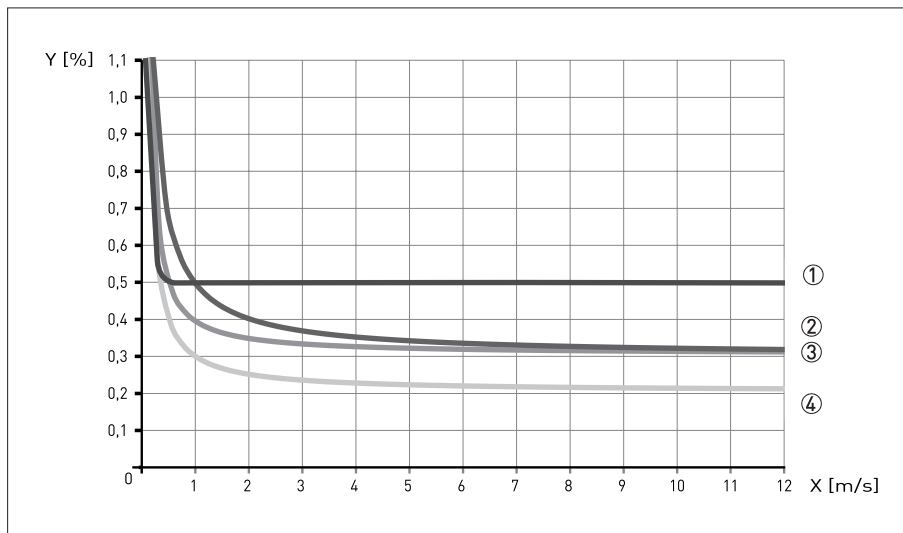

Figure 2-3: Flow velocity vs. accuracy

X [m/s] : flow velocity

Y [%]: deviation from the actual measured value (mv)

### Accuracy

Sensor diameter	Converter type	Accuracy	Curve
DN25...1200 / 1...48"	IFC 050	0.5% of mv above 0,5 m/s, below 0,5 m/s, deviation $\pm 2.5$ mm/s	①
DN25...1200 / 1...48"	IFC 100	0.3% of mv + 1 mm/s	③
DN25...1600 / 1...64"	IFC 300	0.2% of mv + 1 mm/s	④
DN1800...3000 / > 64"	IFC 300	0.3% of mv + 2 mm/s	②

### 2.4 Pressure derating

The graphs below refer to the maximum pressure as a function of the temperature for the flanges of the flowmeter (per specified flange material).

Please note that the specified values only refer to the flanges. The maximum value for the flowmeter can further be limited by the maximum value for other materials ( o.a. the liner )

For A = Carbonsteel A 105 & B = Stainless steel 316L

X/Y axes in all graphs ; X = Temperature in [°C] / Y = Pressure in [bar]

x/y axes in all graphs ; x = Temperature in [°F] / y = Pressure in [psi]

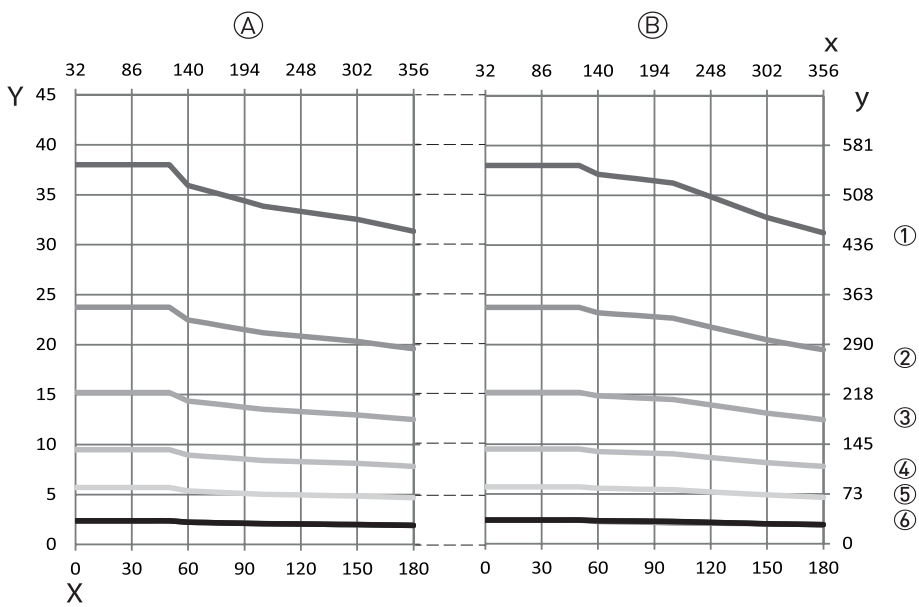

Figure 2-4: Pressure derating; EN 1092-1

- ① PN 2.5
- ② PN 6
- ③ PN 10
- ④ PN 16
- ⑤ PN 25
- ⑥ PN 40

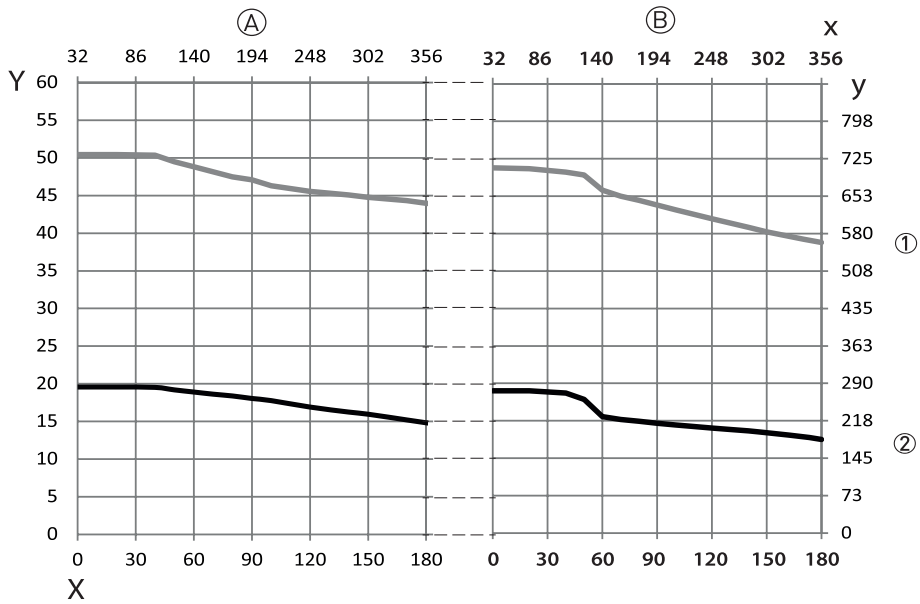

Figure 2-5: Presurre derating; ANSI B 16.5

- ① 300 lbs
- ② 150 lbs

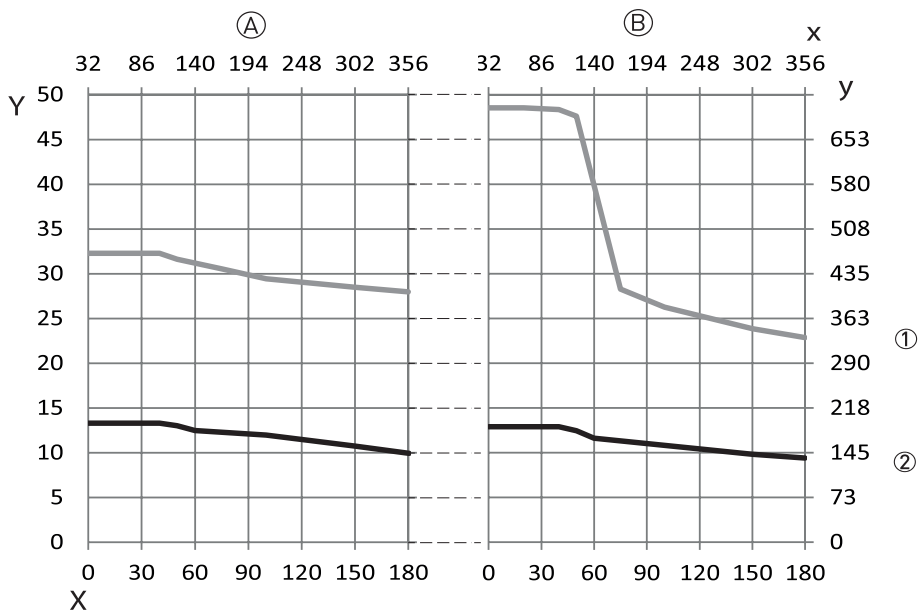

Figure 2-6: Pressure derating; JIS B2220

- ① 20K
- ② 10K

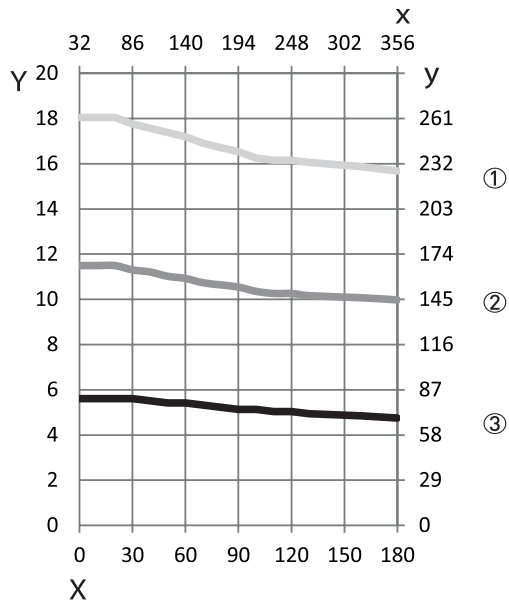

Figure 2-7: Presurre derating; AWWA C207

- ① Class D2 [>12"]
- ② Class D1 [4...12"]
- ③ Class B

## 2.5 Vacuum load

Diameter	Vacuum load in mbar abs. at a process temperature of			
[mm]	20°C	40°C	60°C	80°C
<b>Hard rubber</b>				
DN200...300	250	250	400	400
DN350...1000	500	500	600	600
DN1200...3000	600	600	750	750
<b>Polypropylene</b>				
DN25...150	250	250	400	400
<b>Polyolefin</b>				
DN200...1000	0	0	0	0

Diameter	Vacuum load in psia at process temperature of			
[inches]	68°F	104°F	140°F	176°F
<b>Hard rubber</b>				
8...12"	3.6	3.6	5.8	5.8
14...40"	7.3	7.3	8.7	8.7
48...120"	8.7	8.7	10.9	10.9
<b>Polypropylene</b>				
1...6"	3.6	3.6	5.8	5.8
<b>Polyolefin</b>				
8...40"	0	0	0	0

2.6 Dimensions and weights

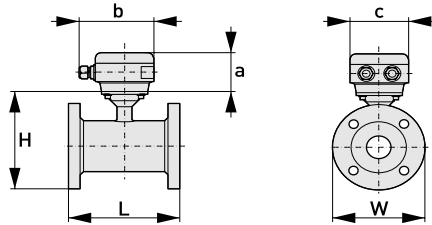
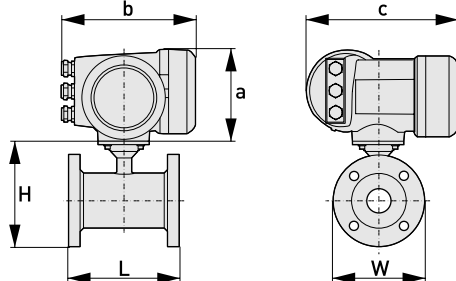
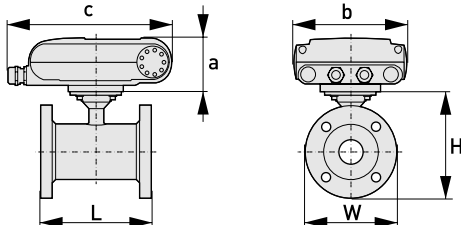
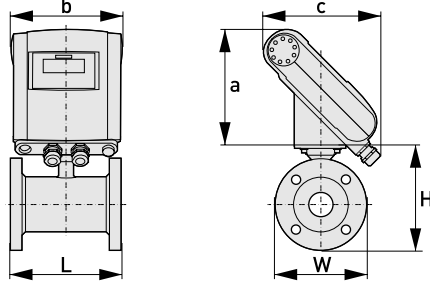
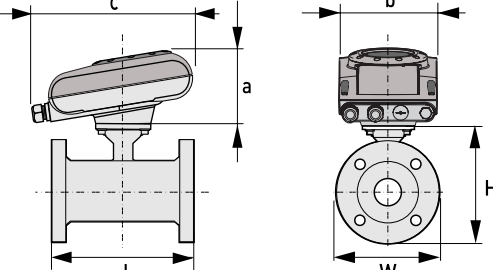
<p>Remote version</p>		<p>a = 88 mm / 3.5"                      b = 139 mm / 5.5" ①                      c = 106 mm / 4.2"                      Total height = H + a</p>
<p>Compact version with IFC 300</p>		<p>a = 155 mm / 6.1"                      b = 230 mm / 9.1" ①                      c = 260 mm / 10.2"                      Total height = H + a</p>
<p>Compact version with IFC 100 (0°)</p>		<p>a = 82 mm / 3.2"                      b = 161 mm / 6.3"                      c = 257 mm / 10.1" ①                      Total height = H + a</p>
<p>Compact version with IFC 100 (45°)</p>		<p>a = 186 mm / 7.3"                      b = 161 mm / 6.3"                      c = 184 mm / 7.3" ①                      Total height = H + a</p>
<p>Compact version with IFC 050 (10°)</p>		<p>a = 101 mm / 3.98"                      b = 157 mm / 6.18"                      c = 260 mm / 10.24" ①                      Total height = H + a</p>

① The value may vary depending on the used cable glands.



- All data given in the following tables are based on standard versions of the flow sensor only.
- Especially for smaller nominal sizes of the flow sensor, the signal converter can be bigger than the flow sensor.
- Note that for other pressure ratings than mentioned, the dimensions may be different.
- For full information on signal converter dimensions see relevant documentation.

## EN 1092-1

Nominal size DN [mm]	Dimensions [mm]				Approx. weight [kg]
	Standard length	ISO Insertion length	H	W	
25	150	200	140	115	5
32	150	200	157	140	6
40	150	200	166	150	7
50	200	200	186	165	11
65	200	200	200	185	9
80	200	200	209	200	14
100	250	250	237	220	15
125	250	250	266	250	19
150	300	300	300	285	27
200	350	350	361	340	34
250	400	450	408	395	48
300	500	500	458	445	58
350	500	550	510	505	78
400	600	600	568	565	101
450	600	-	618	615	111
500	600	-	671	670	130
600	600	-	781	780	165
700	700	-	898	895	248
800	800	-	1012	1015	331
900	900	-	1114	1115	430
1000	1000	-	1225	1230	507
1200	1200	-	1417	1405	555
1400	1400	-	1619	1630	765
1600	1600	-	1819	1830	1035
1800	1800	-	2027	2045	1470
2000	2000	-	2259	2265	1860

## ASME B16.5 / 150 lb flanges

Nominal size [inches]	Dimensions [inches]			Approx. weight [lb]
	L	H	W	
1"	5.91	5.39	4.25	7
1½"	5.91	6.10	5.00	11
2"	7.87	7.05	5.98	18
3"	7.87	8.03	7.50	26
4"	9.84	9.49	9.00	44
5"	9.84	10.55	10.00	49
6"	11.81	11.69	11.00	64
8"	13.78	14.25	13.50	95
10"	15.75	16.30	16.00	143
12"	19.69	18.78	19.00	207
14"	27.56	20.67	21.00	284
16"	31.50	22.95	23.50	364
18"	31.50	24.72	25.00	410
20"	31.50	26.97	27.50	492
24"	31.50	31.38	32.00	675

## ASME B16.5 / 300 lb flanges

Nominal size [inches]	Dimensions [inches]			Approx. weight [lb]
	L	H	W	
1"	5.91	5.71	4.87	11
1½"	7.87	6.65	6.13	13
2"	9.84	7.32	6.50	22
3"	9.84	8.43	8.25	31
4"	11.81	10.00	10.00	44
6"	12.60	12.44	12.50	73
8"	15.75	15.04	15.00	157
10"	19.69	17.05	17.50	247
12"	23.62	20.00	20.50	375
14"	27.56	21.65	23.00	474
16"	31.50	23.98	25.50	639
20"	31.50	28.46	30.50	937
24"	31.50	33.39	36.00	1345

### 3.1 Intended use

*Responsibility for the use of the measuring devices with regard to suitability, intended use and corrosion resistance of the used materials against the measured fluid lies solely with the operator.*

*The manufacturer is not liable for any damage resulting from improper use or use for other than the intended purpose.*

This electromagnetic flowmeter is designed exclusively to measure the flow of electrically conductive, liquid media.

*If the device is not used according to the operating conditions (refer to chapter Technical data), the intended protection could be affected.*

### 3.2 General notes on installation

*Inspect the packaging carefully for damages or signs of rough handling. Report damage to the carrier and to the local office of the manufacturer.*

*Do a check of the packing list to make sure that you have all the elements given in the order.*

*Look at the device nameplate to ensure that the device is delivered according to your order. Check for the correct supply voltage printed on the nameplate.*

#### 3.2.1 Vibration

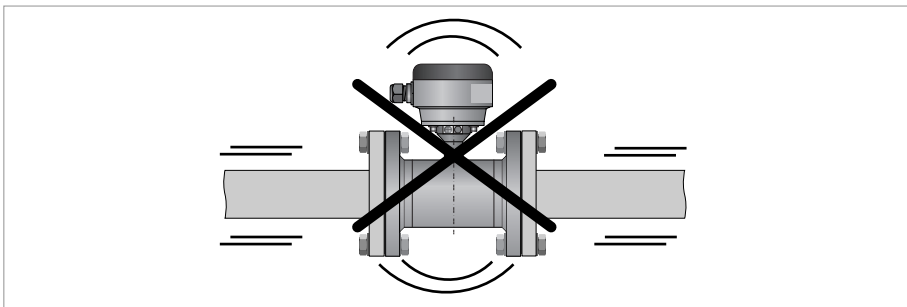

Figure 3-1: Avoid vibrations

#### 3.2.2 Magnetic field

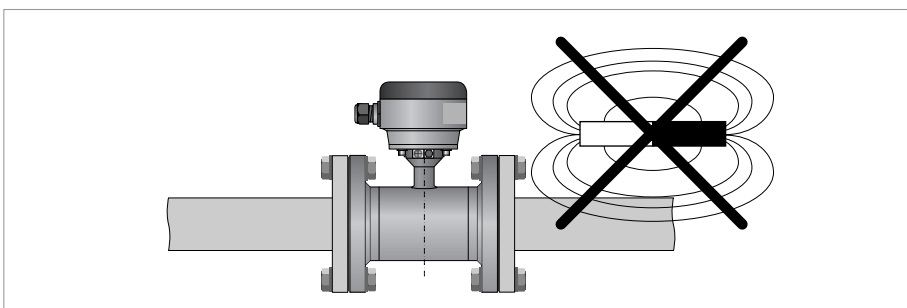

Figure 3-2: Avoid magnetic fields

### 3.3 Installation conditions

#### 3.3.1 Inlet and outlet

Use straight inlet and outlet pipe sections to prevent flow distortion or swirl, caused by bends and T- sections.

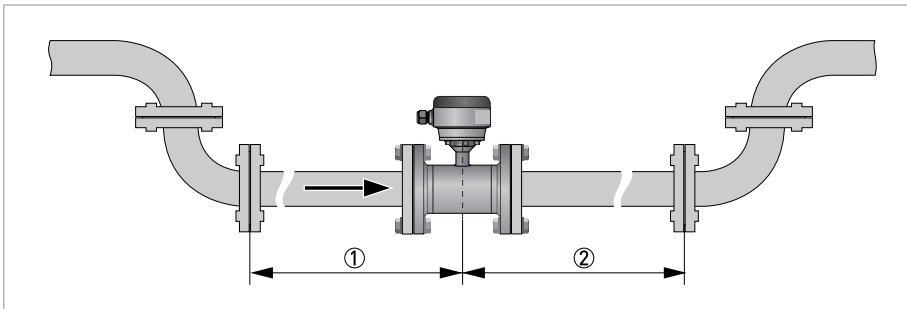

Figure 3-3: Recommended inlet and outlet section

- ① Refer to chapter "Bends in 2 or 3 dimensions"
- ②  $\geq 2 \text{ DN}$

#### 3.3.2 Bends in 2 or 3 dimensions

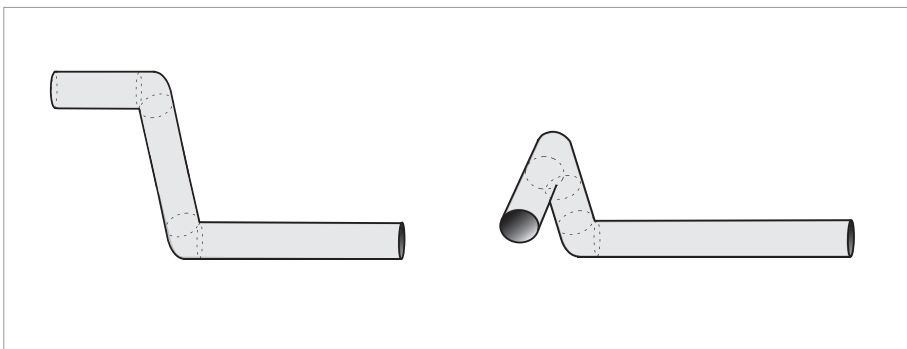

Figure 3-4: 2 and 3 dimensional bends, in front of flowmeter

- ① Bends in 2 dimensions:  $\geq 5 \text{ DN}$ ; bends in 3 dimensions:  $\geq 10 \text{ DN}$

#### 3.3.3 T-section

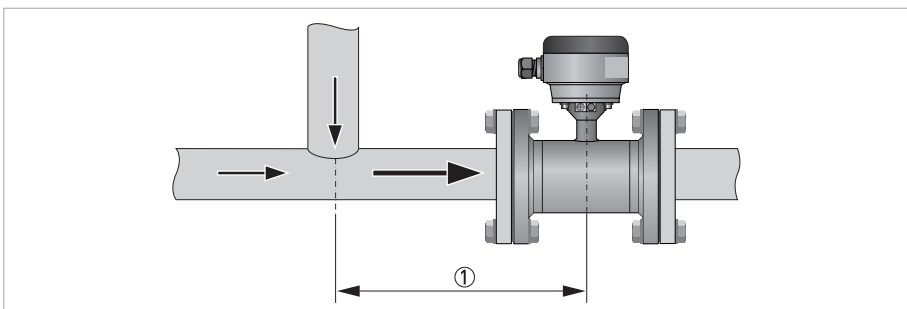

Figure 3-5: Distance behind a T-section

- ①  $\geq 10 \text{ DN}$

### 3.3.4 Bends

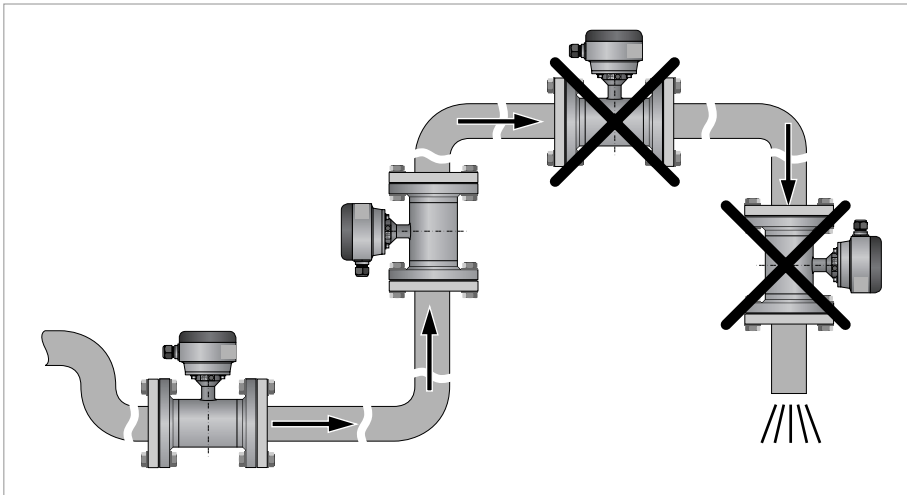

Figure 3-6: Installation in bending pipes

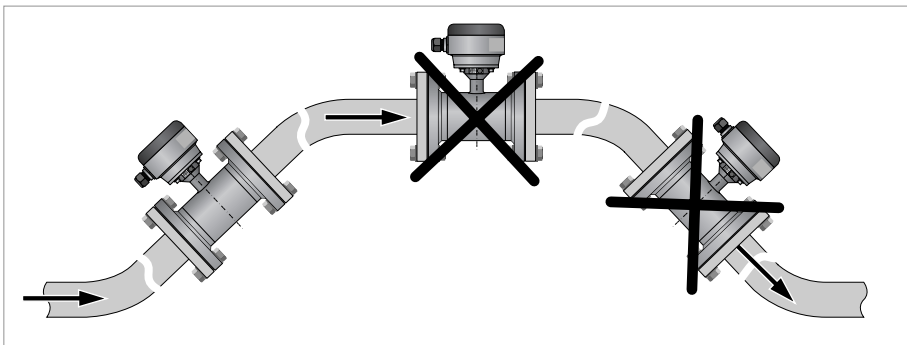

Figure 3-7: Installation in bending pipes

*Avoid draining or partial filling of the flow sensor*

### 3.3.5 Open feed or discharge

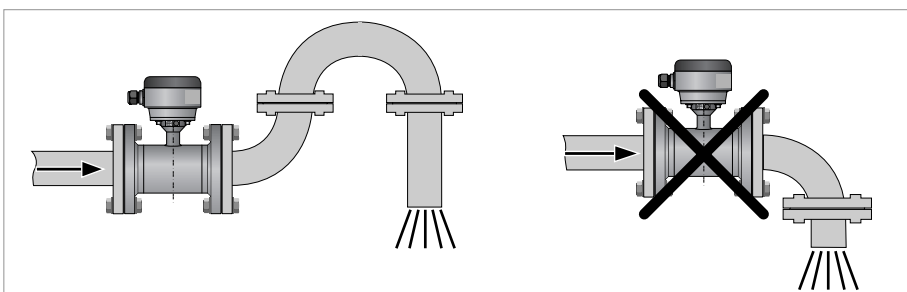

Figure 3-8: Installation in front of an open discharge

### 3.3.6 Flange deviation

Max. permissible deviation of pipe flange faces:  
 $L_{max} - L_{min} \leq 0.5 \text{ mm} / 0.02''$

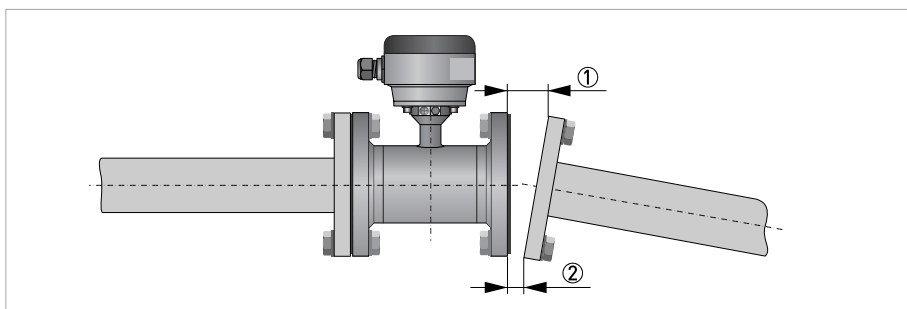

Figure 3-9: Flange deviation

- ①  $L_{max}$
- ②  $L_{min}$

### 3.3.7 Pump

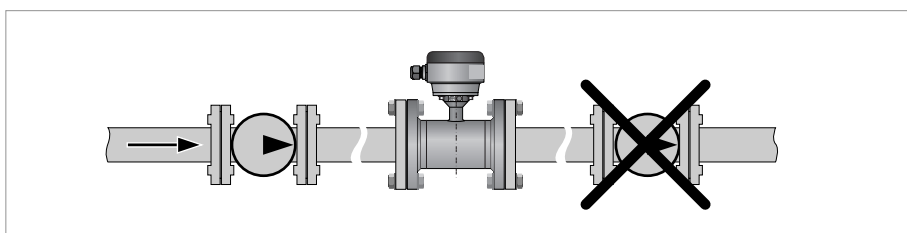

Figure 3-10: Installation behind a pump

### 3.3.8 Control valve

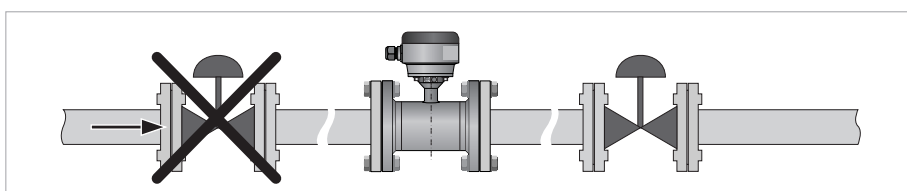

Figure 3-11: Installation in front of a control valve

### 3.3.9 Air venting and vacuum forces

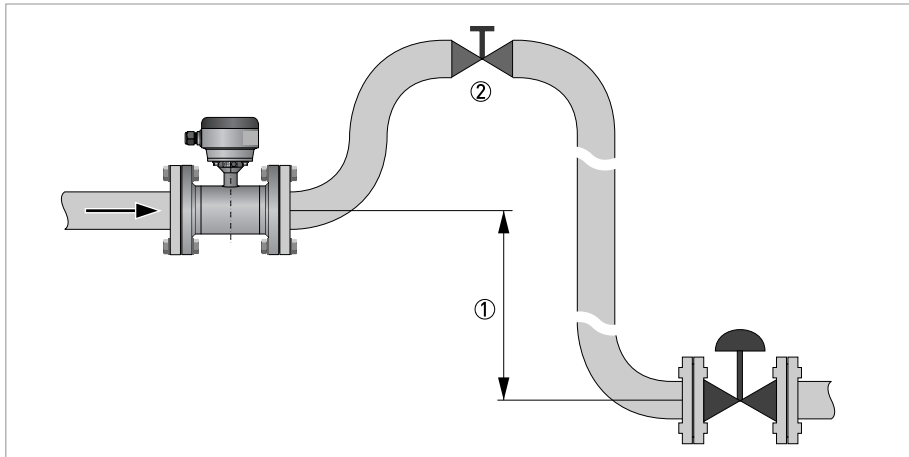

Figure 3-12: Air venting

①  $\geq 5$  m

② Air ventilation point

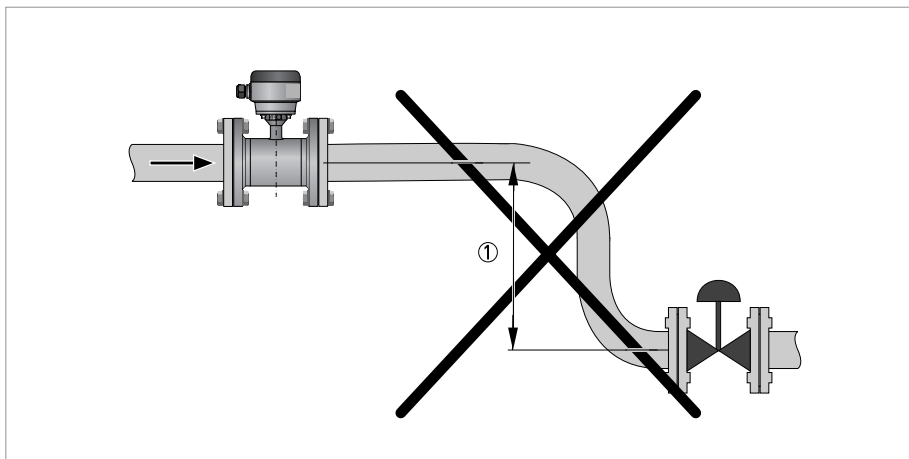

Figure 3-13: Vacuum

①  $\geq 5$  m

### 3.3.10 Mounting position

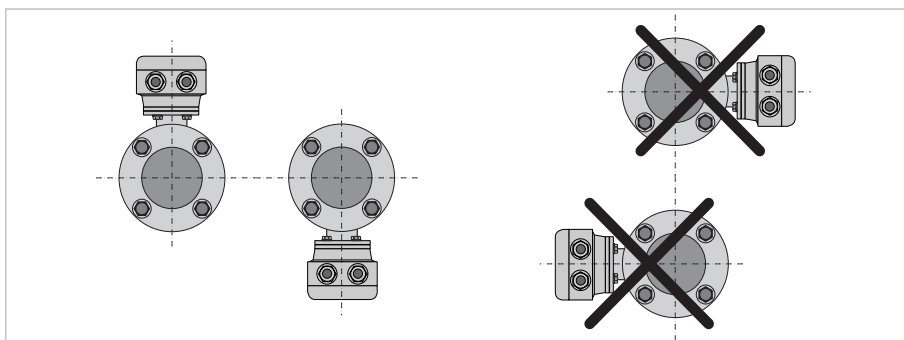

Figure 3-14: Mounting position

## 3.4 Mounting

### 3.4.1 Torques and pressures

The maximum pressure and torques values for the flowmeter are theoretical and calculated for optimum conditions and use with carbon steel flanges.

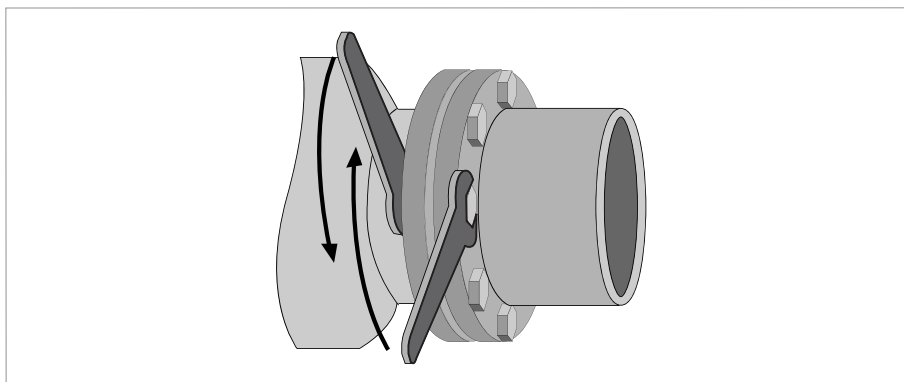

Figure 3-15: Tightening of bolts

#### Tightening of bolts

- Always tighten the bolts uniformly and in diagonally opposite sequence.
- Do not exceed the maximum torque value.
- Step 1: Apply approx. 50% of max. torque given in table.
- Step 2: Apply approx. 80% of max. torque given in table.
- Step 3: Apply 100% of max. torque given in table.



Nominal size DN [mm]	Pressure rating	Bolts	Max. torque [Nm] <sup>①</sup>		
			Polyolefin	Polypropylene	Hard rubber
25	PN 40	4 x M 12	-	22	11
32	PN 40	4 x M 16	-	37	19
40	PN 40	4 x M 16	-	43	25
50	PN 40	4 x M 16	-	55	31
65	PN 16	② x M 16	-	51	42
65	PN 40	8 x M 16	-	38	21
80	PN 40	8 x M 16	-	47	25
100	PN 16	8 x M 16	-	39	30
125	PN 16	8 x M 16	-	53	40
150	PN 16	8 x M 20	-	68	47
200	PN 10	8 x M 20	68	-	68
200	PN 16	12 x M 20	45	-	45
250	PN 10	12 x M 20	65	-	65
250	PN 16	12 x M 24	78	-	78
300	PN 10	12 x M 20	76	-	76
300	PN 16	12 x M 24	105	-	105
350	PN 10	16 x M 20	75	-	75
400	PN 10	16 x M 24	104	-	104
450	PN 10	20 x M 24	93	-	93
500	PN 10	20 x M 24	107	-	107
600	PN 10	20 x M 27	138	-	138
700	PN 10	24 x M 27	163	-	163
800	PN 10	24 x M 30	219	-	219
900	PN 10	28 x M 30	205	-	205
1000	PN 10	28 x M 33	261	-	261

① The specified torque values are dependent on variables (temperature, bolt material, gasket material, lubricants, etc.) which are not within the control of the manufacturer. Therefore the values should be regarded as indicative only.

② DN65 / PN16 is available with standard 8 bolt holes. On request 4 bolt holes is optional.

*Other sizes / pressure ratings on request.*

Nominal size [inch]	Flange class [lb]	Bolts	Max. torque [lb.ft] ①		
			Polyolefin	Polypropylene	Hard rubber
1	150	4 x 1/2"	-	6.7	3.2
1 1/2	150	4 x 1/2"	-	13	9
2	150	4 x 5/8"	-	24	17
3	150	4 x 5/8"	-	43	29
4	150	8 x 5/8"	-	34	23
6	150	8 x 3/4"	-	61	38
8	150	8 x 3/4"	51	-	51
10	150	12 x 7/8"	58	-	58
12	150	12 x 7/8"	77	-	77
14	150	12 x 1"	69	-	69
16	150	16 x 1"	67	-	67
18	150	16 x 1 1/8"	105	-	105
20	150	20 x 1 1/8"	94	-	94
24	150	20 x 1 1/4"	133	-	133
28	150	28 x 1 1/4"	119	-	119
32	150	28 x 1 1/2"	191	-	191
36	150	32 x 1 1/2"	198	-	198
40	150	36 x 1 1/2"	198	-	198

① The specified torque values are dependent on variables (temperature, bolt material, gasket material, lubricants, etc.) which are not within the control of the manufacturer. Therefore the values should be regarded as indicative only.

*Other sizes / pressure ratings on request.*

- *Pressures are applicable at 20°C / 68°F.*
- *For higher temperatures, the pressure ratings are as per ASME B16.5.*

## 4.1 Safety instructions

*All work on the electrical connections may only be carried out with the power disconnected. Take note of the voltage data on the nameplate!*

*Observe the national regulations for electrical installations!*

*Observe without fail the local occupational health and safety regulations. Any work done on the electrical components of the measuring device may only be carried out by properly trained specialists.*

*Look at the device nameplate to ensure that the device is delivered according to your order. Check for the correct supply voltage printed on the nameplate.*

## 4.2 Grounding

*The device must be grounded in accordance with regulations in order to protect personnel against electric shocks.*

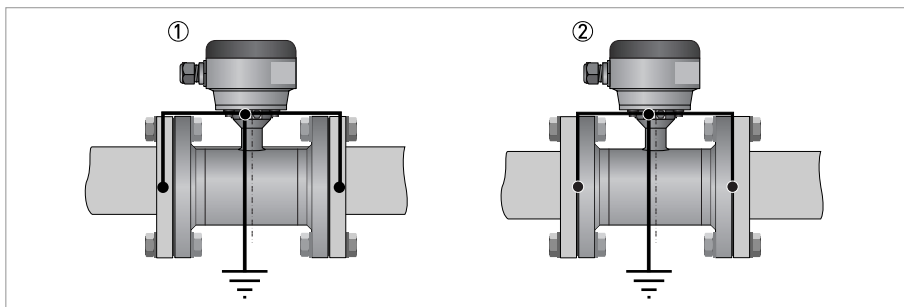

**Figure 4-1: Grounding**

- ① Metal pipelines, not internally coated. Grounding without grounding rings.
- ② Metal pipelines with internal coating and non-conductive pipelines. Grounding with grounding rings.

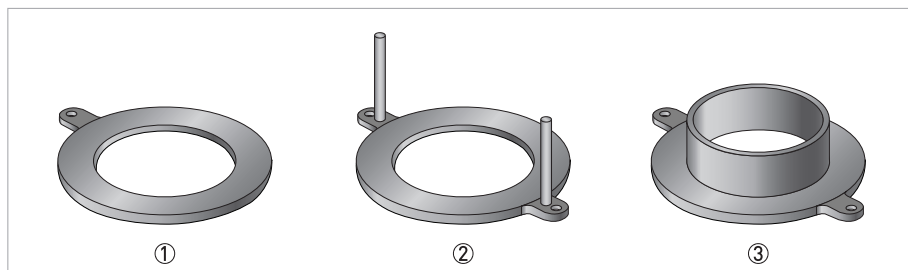

Figure 4-2: Different types of grounding rings

- ① Grounding ring number 1
- ② Grounding ring number 2
- ③ Grounding ring number 3

#### Grounding ring number 1:

- 3 mm / 0.1" thick (tantalum: 0.5 mm / 0.02")

#### Grounding ring number 2:

- 3 mm / 0.1" thick
- Prevents damage to the flanges during transport and installation
- Especially for flow sensors with PTFE liner

#### Grounding ring number 3:

- 3 mm / 0.1" thick
- With cylindrical neck (length 30 mm / 1.25" for DN10...150 / 3/8...6")
- Prevents damage to the liner when abrasive liquids are used

### 4.3 Virtual reference for IFC 300 (C, W and F version)

The virtual reference option on the IFC 300 flow converter provides complete isolation of the measurement circuit.

**Benefits of virtual reference:**

- Grounding rings or grounding electrodes can be omitted.
- Safety increases by reducing the number of potential leakage points.
- The installation of the flowmeters is much easier.

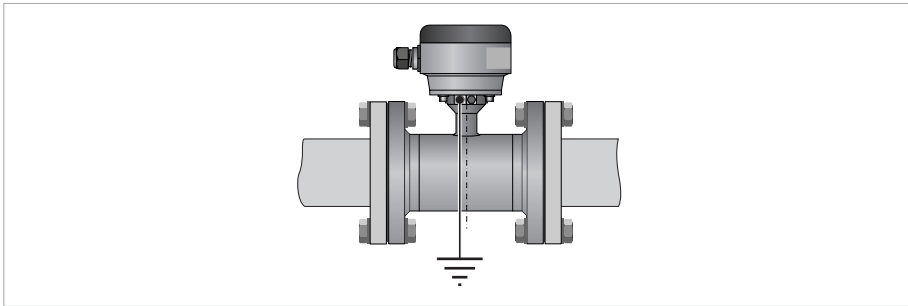

Figure 4-3: Virtual reference

**Minimum requirements:**

- Size:  $\geq$  DN10
- Electrical conductivity:  $\geq 200 \mu\text{S/cm}$
- Electrode cable: max. 50 m / 164 ft, type DS

### 4.4 Connection diagrams

*For the connection diagrams please refer to the documentation of the applicable signal converter.*





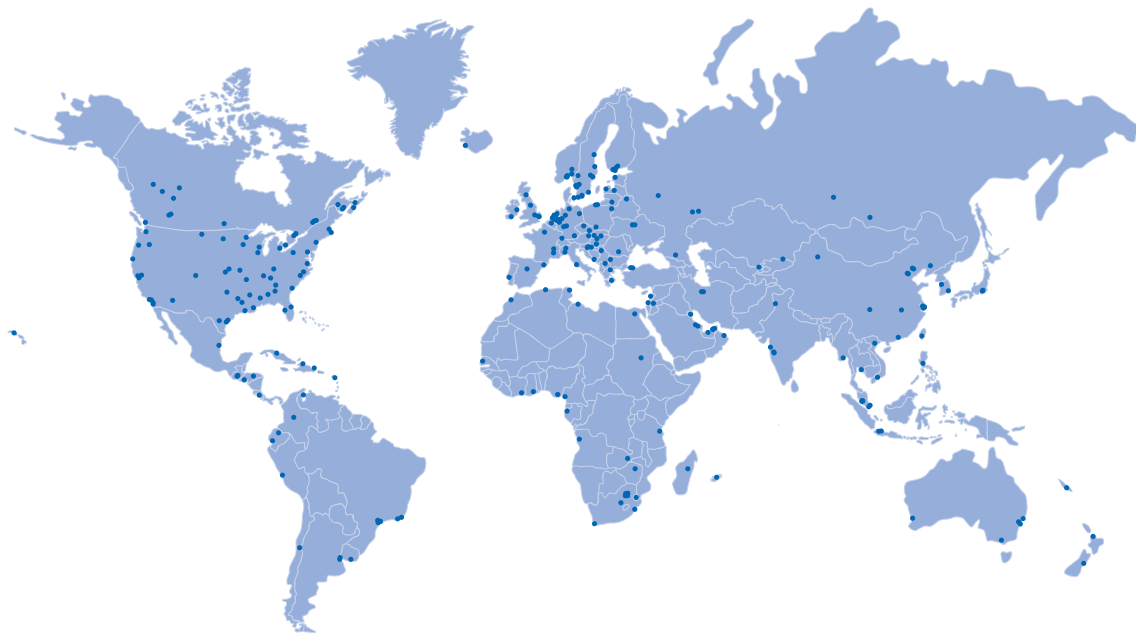

### KROHNE product overview

- Electromagnetic flowmeters
- Variable area flowmeters
- Ultrasonic flowmeters
- Mass flowmeters
- Vortex flowmeters
- Flow controllers
- Level meters
- Temperature assemblies
- Pressure transmitters
- Analysis products
- Products and systems for the oil & gas industry
- Measuring systems for the marine industry

Head Office KROHNE Messtechnik GmbH  
Ludwig-Krohne-Str. 5  
47058 Duisburg (Germany)  
Tel.: +49 203 301 0  
Fax: +49 203 301 103 89  
info@krohne.com

The current list of all KROHNE contacts and addresses can be found at:  
[www.krohne.com](http://www.krohne.com)

**KROHNE**