



USER INSTRUCTIONS

Limitorque® UEX

Electronic Controls Module

FCD LMENIM1205-04-A4 – 11/15

Installation
Operation
Maintenance

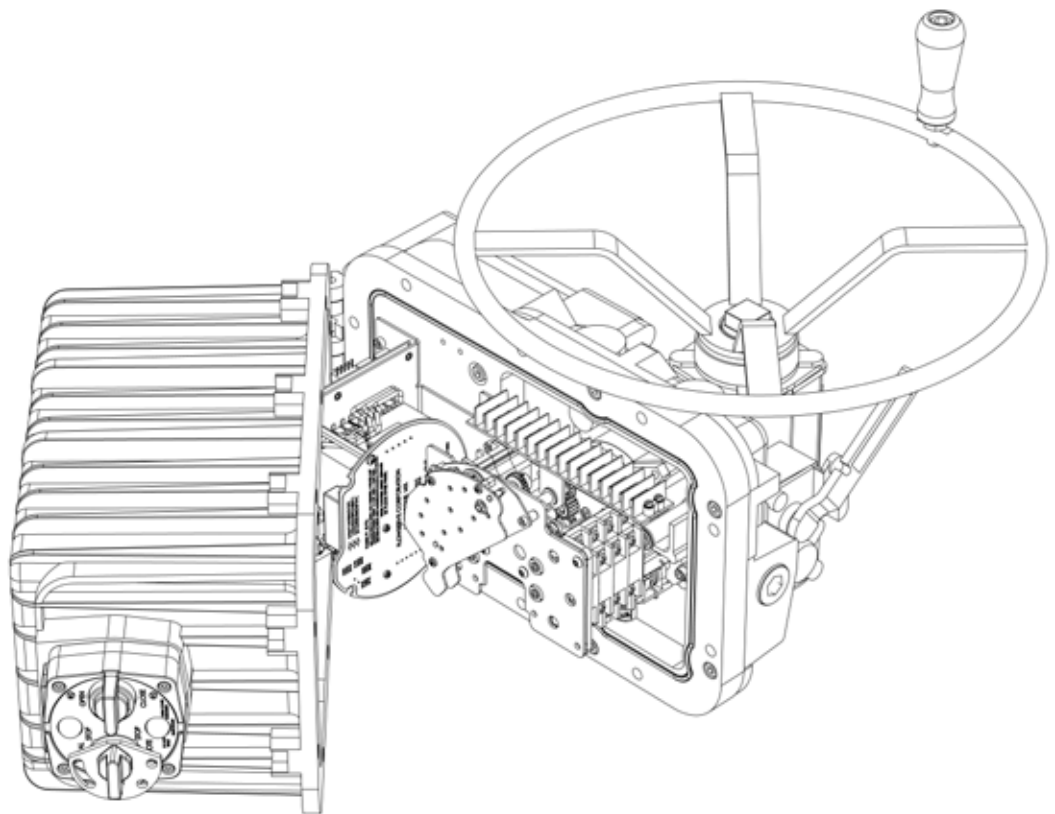

Contents

1. Introduction	4
1.1 Purpose	4
1.2 User Safety	4
1.3 Product Description	5
2. Safety	6
2.1 Safety Precautions	6
2.2 Safety Practices	7
3. Limit Switch and Torque Switch Setting Procedures	8
3.1 Initial Actuator Preparation	8
3.2 Torque Switch	8
3.2.1 Setting Torque Switch	8
3.2.2 Balancing Torque Switch	9
3.3 Geared Limit Switch	10
3.3.1 Setting Limit Switch	10
3.3.2 Setting Procedure (Refer to Figure 3.2)	11
3.3.3 Combination of Contacts (Refer to Figure 3.2)	12
4. Removal of UEC-3 Electronic Controller	13
5. UEX Electronic Controller Installation	18
6. Standard Control Features	22
6.1 Basic Specifications	22
6.2 Local Control	23
6.3 Remote Control Modes of Operation	23
6.4 Emergency Shutdown (ESD)	24
6.5 Remote External Interlocks/Inhibits	25
6.6 Absolute Position Encoder	25
7. Protection Features	26
7.1 Autophase Protection and Correction	26
7.2 Jammed Valve Protection	26
7.3 Instantaneous Reversal Protection	26
7.4 Motor Thermal Protection	26
8. Optional Control Features	27
8.1 Modutronic	27
8.2 Analog Position Transmitter (APT)	28
8.3 Two-Speed Timer	28
8.4 Control Station (CSE)	28
9. Network Communications	29
9.1 Modbus™	29
9.2 Master Station III	30
9.3 Foundation Fieldbus Communication	30
9.4 PROFIBUS DP V1 Communication	31
9.5 PROFIBUS PA Communication	31
9.6 DeviceNet	32
10. Monitoring and Diagnostic Features	33
10.1 Local Features	33
10.2 Diagnostics	34
11. Remote Indication Features	36
11.1 Actuator Status Contacts (S1a, S1b, S2a, S2b)	36
11.2 Monitor Relay (RM)	37
11.3 Exact End Position Indication	37
12. Auxiliary Power Supply	38

13. Isolated Commons	39
14. Actuator Configuration	40
14.1 Local Configuration	40
14.2 Default Configuration	40
14.3 Setup Menus	42
15. UEX Wiring Diagrams	61
16. Network Protocol Connections	67
16.1 Network Wiring – Modbus	67
16.2 Network Wiring – Foundation Fieldbus H1	69
16.3 Network Wiring – Profibus DP and PA	71
16.4 Network Wiring – DeviceNet	72
17. How to Order Parts	74
18. Regulatory Information	75

Figures and Tables

Figure 1.1 – UEX Local Control Panel	5
Figure 3.1 – Microswitch-Style Torque Switch and 600 Volt Torque Switch	9
Figure 3.2 – Limit Switch	11
Figure 3.3 – Setting the Open and Closed Contacts	12
Figure 4.1 – Removal of the UEC-3 Electronic Controller	14
Figure 4.2 – UEC-3, MPC, DDC Assembly	17
Figure 5.1 – Encoder / MDPI / Transformer Installation	19
Figure 5.2 – Power / Interface Board Assembly	19
Figure 5.3 – Main Board Set Installation	20
Figure 5.4 – CSE Jumper Assembly	20
Figure 5.5 – CSE Control Station	20
Figure 5.6 – Controls Compartment Assembly	21
Figure 6.1 – UEX Local Control Panel	22
Figure 6.2 – Absolute Position Encoder	25
Figure 10.1 – Normal and Diagnostic Displays	35
Figure 14.1 – Configuring the UEX Controller	41
Figure 15.1 – Standard Wiring Diagram for UEX Controllers	62
Figure 15.2 – DDC Wiring Diagram for UEX Controllers	63
Figure 15.3 – MOD APT Wiring Diagram for UEX Controllers	64
Figure 15.4 – Optional Features Wiring Diagrams	65
Figure 15.5 – Modbus, Foundation Fieldbus, Profibus DP V1, and Profibus PA, and DeviceNet Network Wiring Diagrams	66
Figure 16.1 – Typical Modbus Network Wiring Diagrams – Single Loop	68
Figure 16.2 – Typical Foundation Fieldbus System with a DCS Host (Daisy Chain Shown)	70
Figure 16.3 – Typical Profibus System with a DCS Host (Daisy Chain Shown)	72
Table 1.1 – Standard Application Voltages with +/- 10% Nominal Range	5
Table 2.1 – Required Rating for External Wiring	7
Table 3.1 – Maximum Number of Drive Sleeve Turns for Standard Four-Gear and Optional Five-Gear Limit Switches	10
Table 3.2 – Limit Switch Parts	11
Table 5.1 – UEX Parts List	21
Table 14.1 – Default Configuration Guidelines	41
Table 16.1 – Specifications for the Profibus Cable	71
Table 16.2 – Maximum Segment Length	71
Table 16.3 – Belden Cable Specifications	73
Table 16.4 – Total Cable Length Between Repeaters or Nodes	73

1

Introduction

1.1 Purpose

This Installation and Maintenance Manual explains how to install, setup, and maintain the UEX controller for the L120-10, L120-20, L120-40, and L120-85 actuators. Information on installation, operation, control features, and maintenance is provided.

Contact Flowserve Limitorque if assistance is needed or preferred for installation, upgrading, or training in the operation of the UEX.

1.2 User Safety

Safety notices in this manual detail precautions the user must take to reduce the risk of personal injury and damage to the equipment. The user must read and be familiar with these instructions before attempting installation, operation, or maintenance. Work should be performed by a qualified tradesman who is familiar with the operation and maintenance of electric actuators. Failure to observe these precautions could result in serious bodily injury or death, damage to the equipment, voiding of the warranty, or operational difficulty.

Safety notices are presented in this manual in three forms:

⚠ **WARNING:** Refers to personal safety. Alerts the user to potential danger. Failure to follow warning notices could result in personal injury or death.

⚠ **CAUTION:** Directs the user's attention to general precautions that, if not followed, could result in personal injury and/or equipment damage.

📌 **NOTE:** Highlights information critical to the user's understanding of the actuator's installation and operation.

1.3 Product Description

The UEX is designed for use with the three-phase L120 electric actuators for weatherproof, explosion-proof, and submersible applications. The UEX is field-retrofitable to replace existing UEC-3 controllers. With state-of-the-art controls based on MX control technology, the UEX offers an expanded feature set when compared to the UEC-3.

Please refer to LMENIM2306 for detailed menu configurations

Table 1.1 Standard Application Voltages with +/- 10% Nominal Range

Design Voltage	Application Voltage
230 VAC, 60 Hz, 3 ph	208/220/230/240 VAC, 60 Hz, 3 ph
460 VAC, 60 Hz, 3 ph	380/400/415/440 VAC, 50 Hz, 3 ph 380/440/460/480 VAC, 60 Hz, 3 ph
525 VAC, 50 Hz, 3 ph	525 VAC, 50 Hz
575 VAC, 60 Hz, 3 ph	550/575/600 VAC, 60 Hz, 3 ph

Figure 1.1 – UEX Local Control Panel

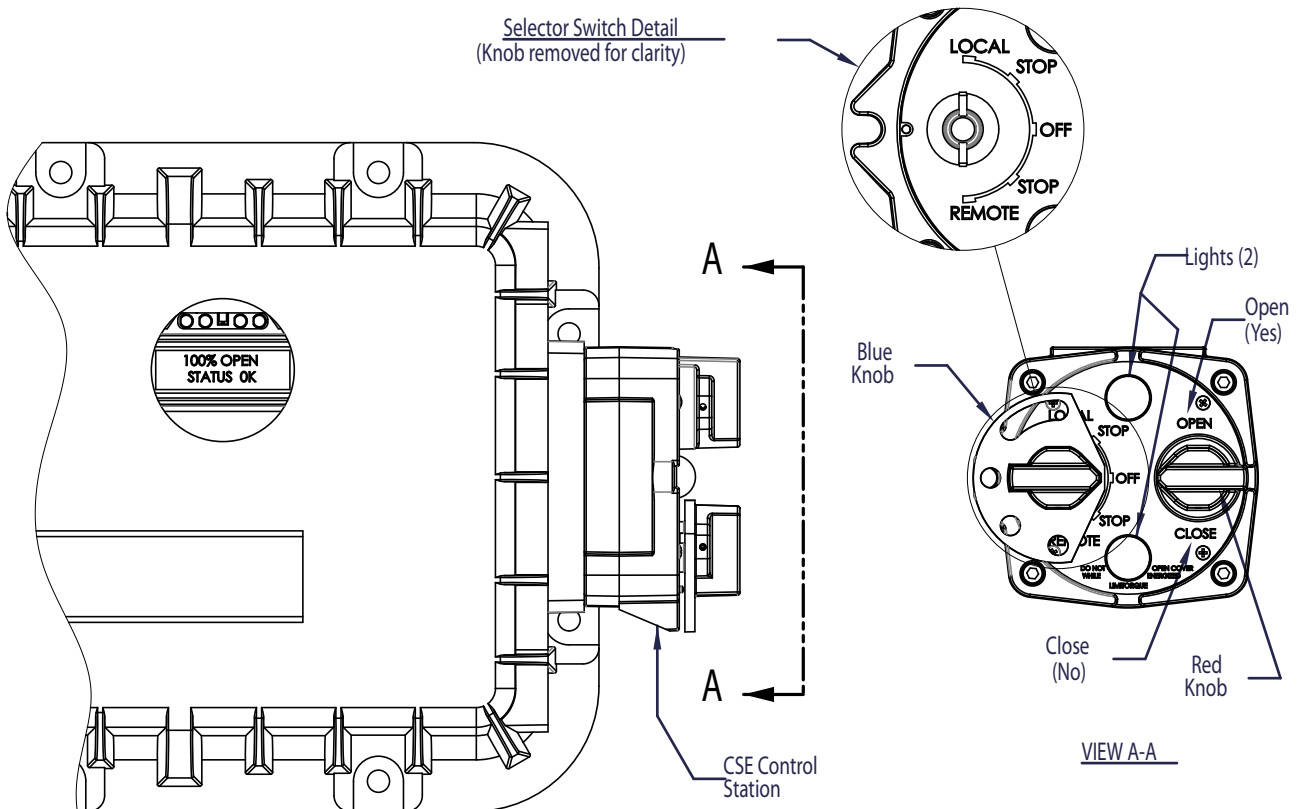

2

Safety

2.1 Safety Precautions

- ⚠ **WARNING:** Read this Installation and Maintenance Manual carefully and completely before attempting to install, operate, or troubleshoot the Limitorque L120 actuator.
- ⚠ **WARNING:** Be aware of electrical hazards. Turn off incoming power before working on the actuator and before opening the switch compartment.
- ⚠ **WARNING:** Potential HIGH-PRESSURE vessel – Be aware of high-pressure hazards associated with the attached valve or other actuated device when installing or performing maintenance on your L120 actuator. Do not remove the actuator mounting bolts when the actuator is mounted on a rising stem valve unless the valve is in the FULLY OPEN position and there is NO pressure in the line.
- ⚠ **WARNING:** Do not manually operate the actuator with devices other than installed Handwheel and Declutch Lever. Using force beyond the ratings of the unit and/or using additive force devices such as cheater bars, wheel wrenches, pipe wrenches, or other devices on the actuator Handwheel or Declutch Lever may cause serious personal injury and/or damage to the actuator or valve.
- ⚠ **WARNING:** For maintenance and/or disassembly of the actuator while installed on the valve, ensure that the actuator is not under thrust or torque load. If the valve must be left in service, the valve stem must be locked in such a way as to prevent any movement of the valve stem.
- ⚠ **WARNING:** For maintenance and/or disassembly of the actuator while installed on the valve, ensure that the actuator is not under thrust or torque load. If the valve must be left in service, the valve stem must be locked in such a way as to prevent any movement of the valve stem.
- ⚠ **WARNING:** Do not attempt to remove the spring cartridge cap, housing cover, or stem nut locknut from the actuator while the valve or actuated device is under load.
- ⚠ **WARNING:** Do not exceed any design limitations or make modifications to this equipment without first consulting Limitorque.
- ⚠ **WARNING:** Actuators equipped with electrical devices (motors, controls) requiring field wiring must be wired and checked for proper operation by a qualified tradesman.

- ⚠ **WARNING:** Use of the product must be suspended any time it fails to operate properly.
- ⚠ **WARNING:** Do not work on the actuator while it is mounted on a torque-seated valve.
- ⚠ **CAUTION:** Do not use oversized motor overload heaters. Instead, look for the cause of the overload.
- ⚠ **CAUTION:** Do not operate the valve under motor operation without first setting or checking the limit switch setting and motor direction.
- ⚠ **CAUTION:** Do not force the declutch lever into the motor operation position. The lever returns to this position automatically when the motor is energized.
- ⚠ **CAUTION:** Do not depress the declutch lever during motor operation to stop valve travel.
- ⚠ **CAUTION:** Do not use replacement parts that are not genuine Flowserve Limitorque parts, as serious personal injury and/or damage to the actuator and valve may result.
- ⚠ **CAUTION:** Do not lift actuator/gearbox or actuator/valve combinations with only the eye bolts in the L120 actuator. These eye bolts are designed for lifting the L120 actuator only.
- ⚠ **CAUTION:** Do not lift the actuator by the handwheel

2.2 Safety Practices

The following checks should be performed to maintain safe operation of the L120 actuator.

- Mount motors on a horizontal plane, if possible.
- Keep the controls compartment clean and dry.
- Keep the valve stem clean and lubricated.
- Set up a periodic operating schedule for infrequently used valves.
- Verify the stem nut is secured tightly by the locknut and that the top thread of the locknut is crimped or staked in two places.
- Use a protective stem cover for rising stem valves. Check valve stem travel and clearance before mounting covers on rising stem valves.
- Verify all actuator wiring is in accordance with the applicable wiring diagram, national and local codes, and Table 2.1.

Table 2.1 – Required Rating for External Wiring

Up to:	Use wire rated at least:
40°C	60°C
60°C	75°C

3 Limit Switch & Torque Switch Setting Procedures

3.1 Initial Actuator Preparation

Replace all molded plastic conduit and top protectors (installed for shipping purposes only) with pipe plugs when installation wiring is complete.

3.2 Torque Switch

The torque switch is designed to protect the actuator in open and close directions.

▲ CAUTION: Disconnect all incoming power before opening limit switch compartment or working on the torque switch.

- Do not use abrasive cloth to clean the contacts on the torque switch.
- Do not torque seat 90° operation valves nor run them against the stops. This may cause damage to the valve.

NOTE: If the actuator operation has been interrupted by the tripping of the torque switch, release torque buildup by operating the actuator manually in the opposite direction until the load is released and the dial has returned to the center position.

3.2.1 Setting Torque Switch

The torque switch was set at the factory according to customer-supplied information regarding necessary torque or thrust output that was provided at the time of the order. The procedure below is provided in the event that the setting needs to be adjusted:

▲ CAUTION: A torque switch limiter plate is provided on most actuators. Do not remove this plate. Do not exceed the setting indicated by this plate without first contacting Flowserve Limitorque service.

- Removal or modification of the torque switch limiter plate will void the actuator warranty.

▲ CAUTION: Installing or adjusting the torque switch with the actuator under load will result in a loss of torque protection.

NOTE: Item letters correspond to Figure 3.1.

1. Place the L120 actuator in manual mode by pulling the declutch lever in the direction shown on the lever.
2. Release the load on the wormshaft spring pack by rotating the handwheel until the valve disk position approximates 50% open.
3. For open and close directions, loosen Screw (A) and move Pointer (B) to desired position. A higher number indicates a high torque and/or thrust output.
4. Tighten Screw (A).
5. Operate the valve electrically to seat the valve and to ensure tight shutoff.
6. Rebalance the torque switch if required. See Section 3.2.2 below for the steps to balance the torque switch.

Figure 3.1 – Microswitch-Style Torque Switch and 600 Volt Torque Switch

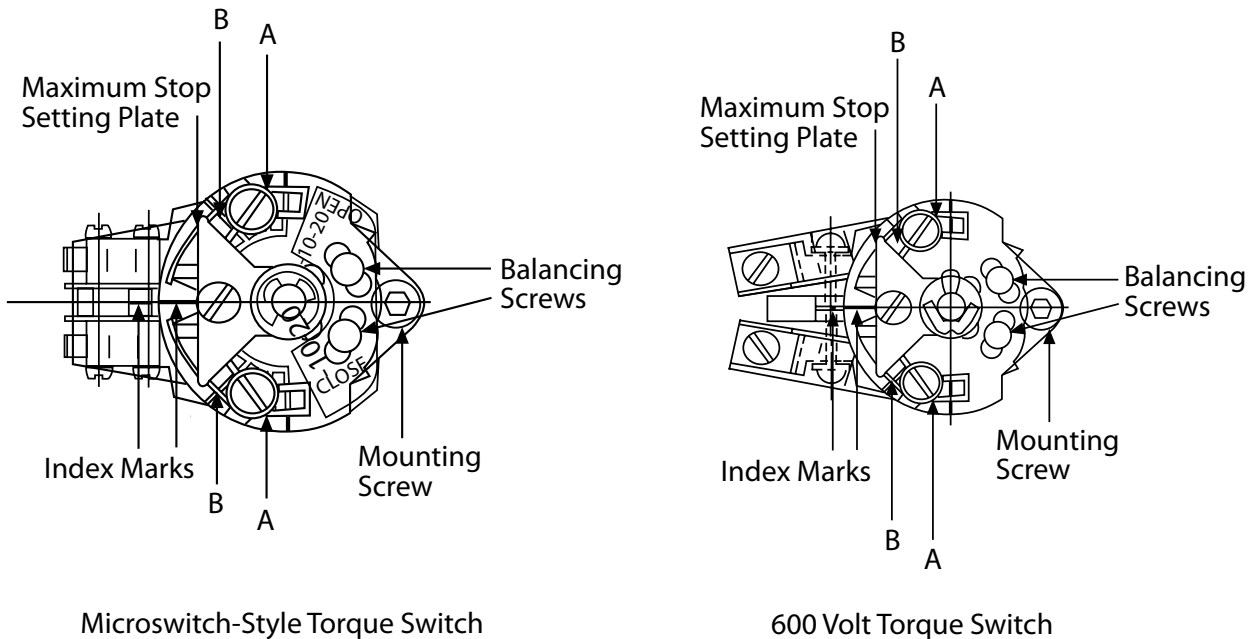

3.2.2 Balancing Torque Switch

▲ CAUTION: The balancing screw on the torque switch should never be readjusted except during the balancing procedure.

If the torque switch has been removed from the unit or if a new torque switch is being installed, the torque switch must be rebalanced using the following procedure:

NOTE: Item letters correspond to Figure 3.1.

1. Place the actuator in manual mode by pulling on the declutch lever in the direction shown on the lever.
2. Remove the load from the wormshaft spring pack by rotating the handwheel until the valve disk approximates 50% open.

3. Note the open and close torque switch settings prior to reinstalling the torque switch.
4. Loosen Screws (A) and position both Pointers (B) at the #1 setting, tighten Screw (A). In this position the index marks should be aligned.
5. Loosen balancing screws and install the torque switch. The base of the torque switch should be flush against the compartment and the hole for the mounting screw should be aligned.
6. Install the mounting screw.
7. Tighten the balancing screws.

▲ CAUTION: The balancing screws should not be touched except during the balancing procedure. The switch is now balanced and ready for the pointers to be returned to their original settings.

3.3 Geared Limit Switch

▲ CAUTION: The geared limit switch is not preset at the factory and must be adjusted after the actuator has been mounted on associated equipment.

- Disconnect all incoming power to the actuator prior to opening the limit switch compartment and adjusting the switch.
- Consult the relevant wiring diagram for limit switch contact development. All L120 units are supplied with 16-contact limit switches - four switches on each of the four rotors. Two rotors are used for end of travel indication. The remaining two rotors may be adjusted for any intermediate point of travel.
- Do not use abrasive cloth to clean the contacts on the limit switch.
- Do not attempt to repair gearing in the limit switch. Replace entire gear frame assembly if necessary.

3.3.1 Setting the Limit Switch

Set the limit switch as follows. All item letters and piece numbers refer to Figure 3.2.

NOTE: The chart below provides the maximum number of drive sleeve turns for each actuator size. The Intermediate Shaft (B), shown in Figure 3.2, may require a considerable number of turns before rotor trip occurs.

Table 3.1 – Maximum Number of Drive Sleeve Turns for Standard Four-Gear and Optional Five-Gear Limit Switches

Actuator Size	Four-Gear	Five-Gear
L120-10	630	6300
L120-20	740	7400
L120-40	640	6400

⚠ WARNING: Potential Explosion Hazard. Do not use an electric drill for setting the limit switch in an explosive environment.

▲ CAUTION: When setting the limit switch rotor segments (cams) using a variable speed electric drill, do not run drill at speeds higher than 200 RPM. Operating the drill at high speeds can damage the gearing within the limit switch.

Figure 3.2 – Limit Switch

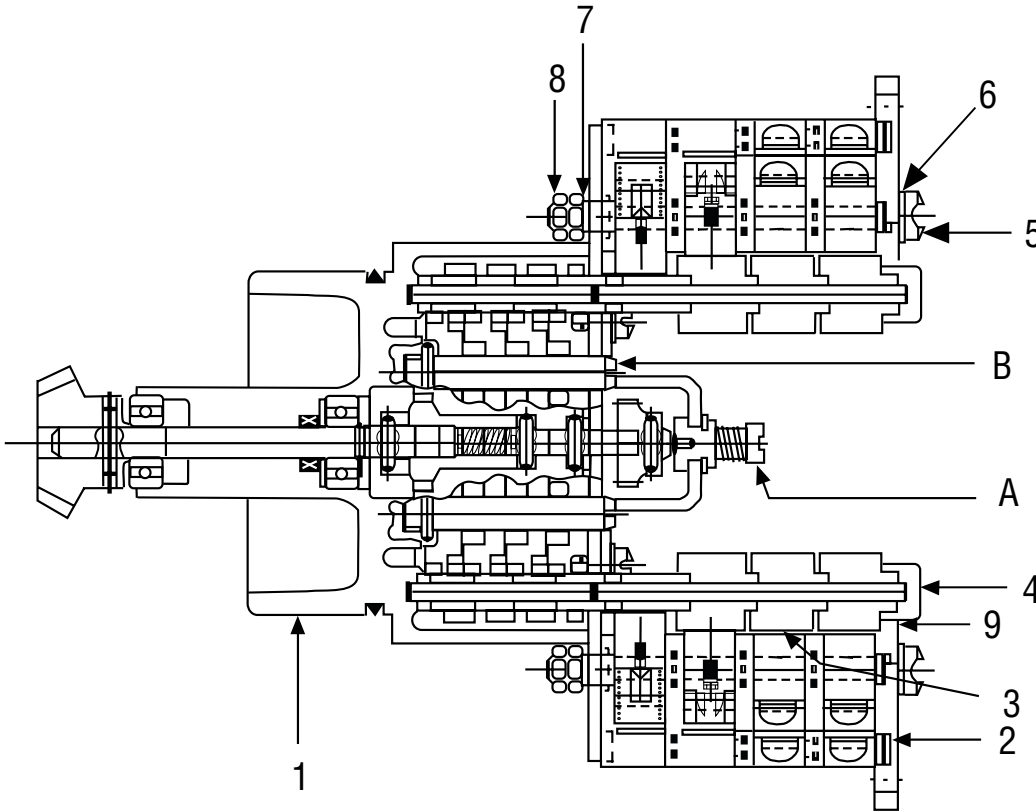

Table 3.2 – Limit Switch Parts

Piece	Quantity	Description
1	1	Gear Frame Assembly
2	2	Eight-Switch Contact Block Assy.
3	12	Rotor Segment (short)
4	4	Rotor Shaft
5	4	Machine Screw
6	4	Flat Washer
7	4	Lock Washer
8	8	Hex Nut
9	4	Rotor Segments (long)

3.3.2 Limit Switch Setting Procedure (Refer to Figure 3.2)

1. Open the Controls Compartment Cover (refer to Figure 5.5).
2. Place the actuator into manual operation by pulling the declutch lever in the direction shown on the lever. Use the handwheel to operate the valve in the “open” direction. While operating the valve, note the direction of the Intermediate Shaft (B) corresponding to the rotor or rotors to be set.
3. When the valve is fully open, rotate the handwheel to operate the valve in the close direction a sufficient number of turns to allow for coast of moving parts, or refer to the valve manufacturer setting requirements.
4. Push in the Setting Rod (A) and turn one-quarter turn. The rod will latch in this depressed position.

5. Refer to the applicable wiring diagram for contact development. The limit switch contact is closed when the rotor is engaged with the plunger. If the rotor to be set has not turned 90 degrees to operate the plunger, turn the intermediate shaft in the same direction as noted in Step 2 until the rotor clearly trips the switches. This rotor is now set correctly.
 6. Before moving the valve disk, depress and turn the Setting Rod (A) one-quarter turn to the spring released position. Insert a screwdriver into the intermediate shafts to ensure that they will not move.
- ▲ CAUTION:** Do not operate the valve when Setting Rod (A) is in a fully depressed position. Loss of contact setting will occur and the setting rod will be damaged.
7. Operate the valve by handwheel to the fully “close” position; reverse direction by a sufficient number of turns of the handwheel to allow for coast of moving parts, or refer to the valve manufacturer setting requirements.
 8. Set the other rotors by following Steps 4 through 6.

Figure 3.3 – Setting the Open and Closed Contacts

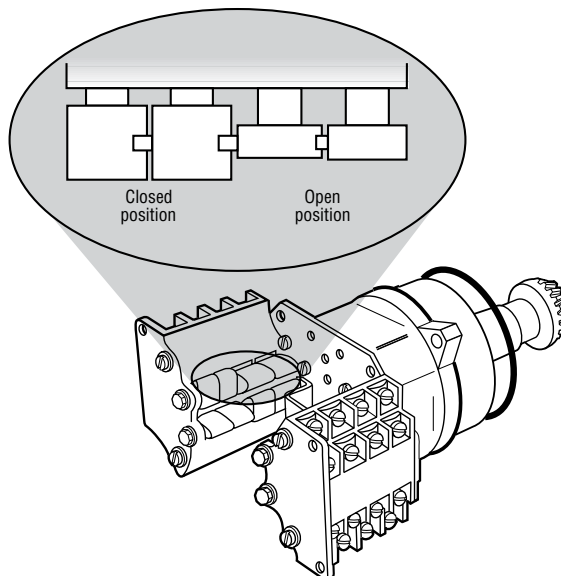

3.3.3 Rotor Contact Combinations (Refer to Figure 3.2)

The rotor segments can be separated and rotated through 90 degrees to give various combinations of normally open or normally closed contacts to each rotor.

1. Remove Nuts (piece 8) and Fillister Head Machine Screws (piece 5, for a total of two fasteners on each side of the switch).
2. Remove complete contact assembly from the back plate.
3. Rearrange cams on the camshaft to produce the required combination of contacts.
4. Replace contact assembly on back-plate (ensuring that the registers fit correctly) and secure with the machine screw and nuts.
5. Set limits according to the procedure above.

NOTE: For mechanical operation and maintenance of the L120 actuators, please see section 5 and 6 of LMENIM1201.

4

Removal of the UEC-3 Electronic Controller

NOTE: Confirm that the limit switches are set properly prior to disassembly and removal of the UEC-3 and related components. Confirming the settings will allow for installation of the UEX Electronic Controller without requiring a reset of the limit switches.

1. Turn off the power to the actuator.
2. Open the Controls Compartment Cover.
3. Cut and remove all wire ties from wiring that is connected to the UEC-3 assembly (pc# C-201).
4. Disconnect the incoming power from the Interconnect Board.
5. Disconnect the Motor leads and Heater leads from the Interconnect Board.
6. Disconnect the Pushbutton Station ribbon cable from the Interconnect Board.
7. Disconnect the Analog-to-Digital Circuit Board (pc# C-223) ribbon cable from the Interconnect Board.
8. Disconnect the R/I circuit board (pc# C-210) ribbon cable
9. Uninstall the Potentiometer by removing the screws that fasten it to the MDPI assembly.
10. Uninstall the MDPI assembly by removing the screws that fasten it to the Geared Limit Switch assembly.
11. Unplug the optional I/O Circuit Board (pc# C-223) from the SBC Board on the UEC-3 Assembly.
12. Label all customer wiring and disconnect from the Interconnect Boards.
13. Remove the four screws from the UEC-3 Assembly (pc# C-201) and carefully remove the Assembly from the Controls Compartment.
14. Remove the Pushbutton Station with ribbon cable from the L120 gear housing conduit entry.

Figure 4.1 - Removal of the UEC-3 Electronic Controller

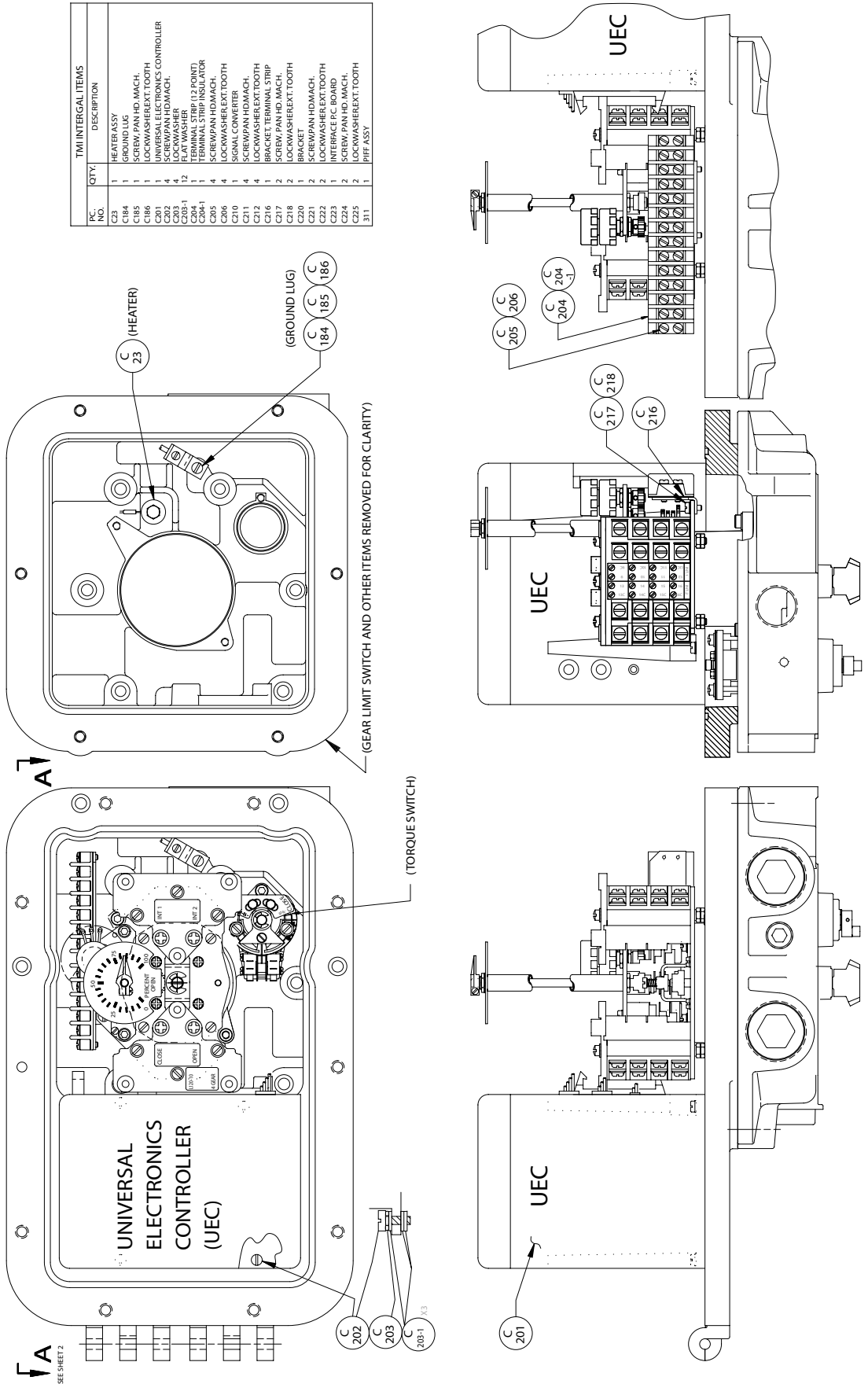
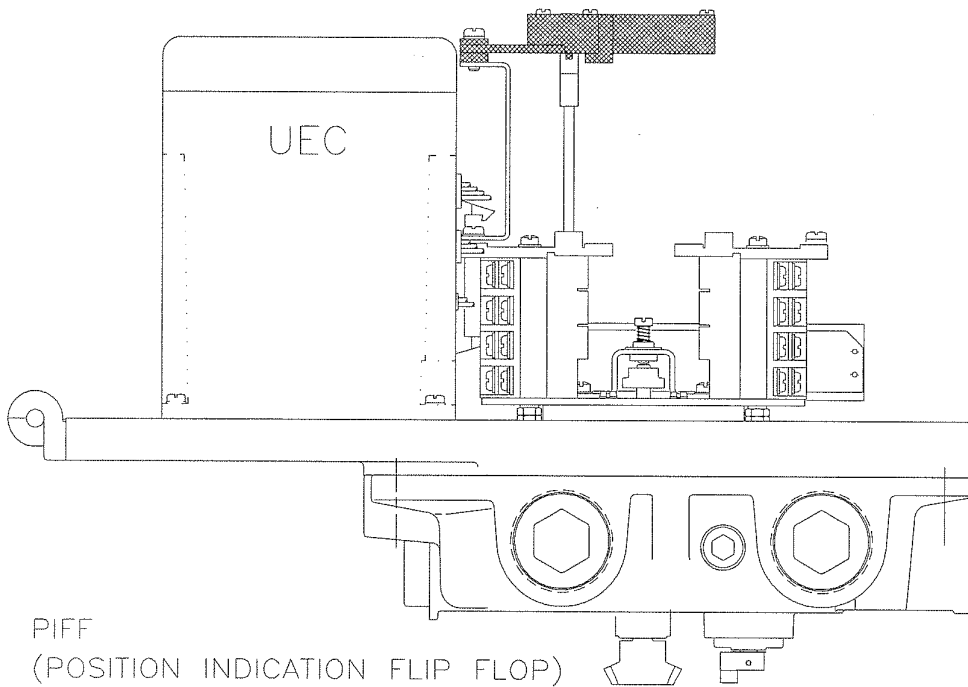
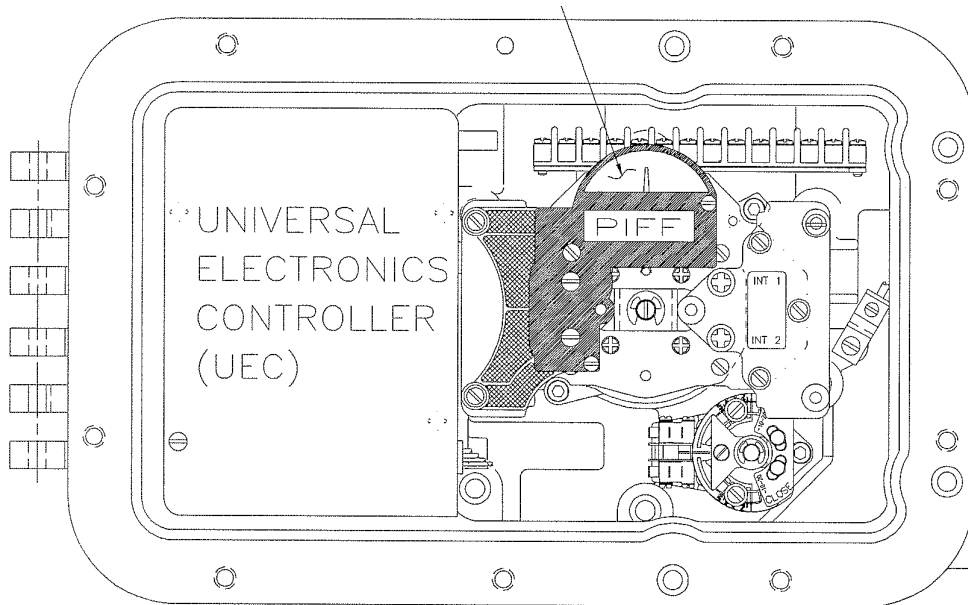
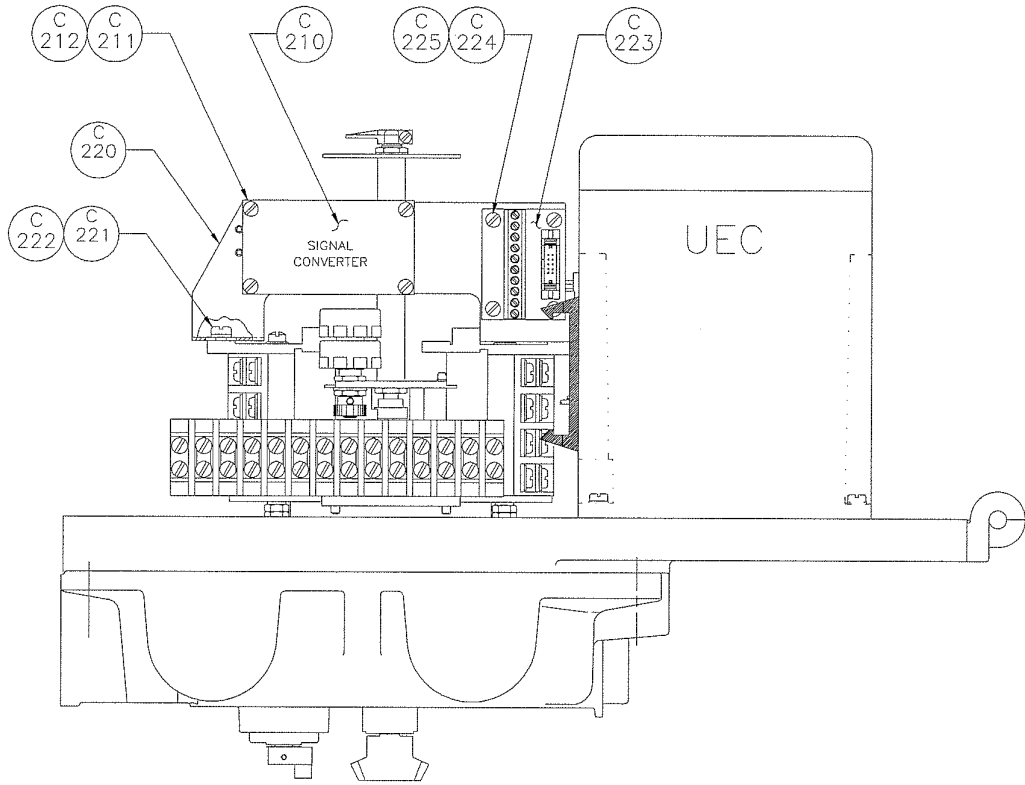

Figure 4.1 – Removal of the UEC-3 Electronic Controller (continued)



PIFF
(POSITION INDICATION FLIP FLOP)
OPTION

Figure 4.1 – Removal of the UEC-3 Electronic Controller (continued)



VIEW A—A
(FROM SHEET 1)

INTERFACE P.C. BOARD / SIGNAL CONVERTER
OPTION

Figure 4.2 – UEC-3, MPC, DDC Assembly

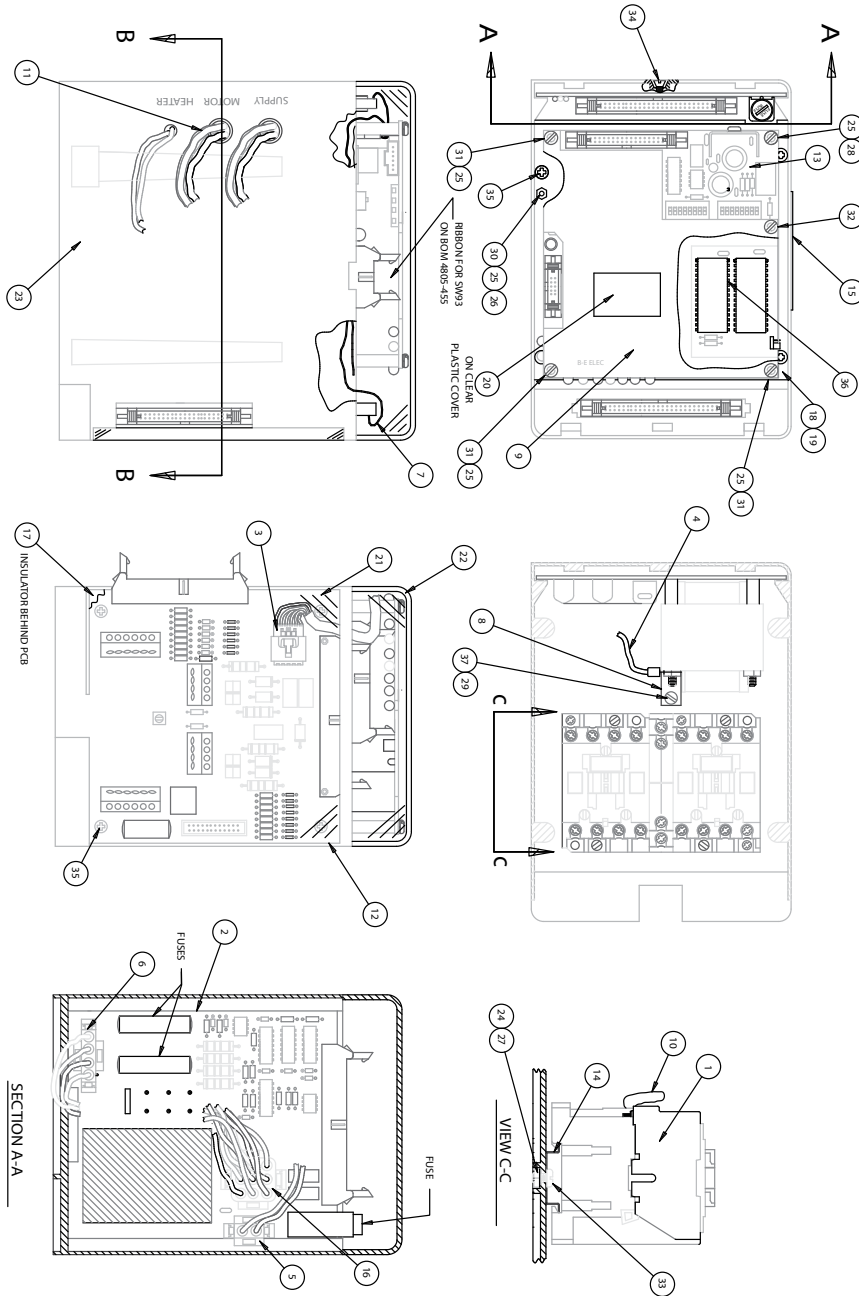

ITEM	QTY.	DESCRIPTION
1	1	REVERSE CONNECTION
2	1	HARNESS, 5W93
3	1	HARNESS, 5W93
4	1	GROUND WIRE, POWER
5	1	HARNESS, HEATER
6	1	HARNESS, HEATER
7	1	HARNESS, CONTROL
8	1	BRACKET, TRANSFORMER
9	1	DAUGHTER BOARD, DDC (NEW)
10	1	MOUNTING BRACKET, 12/24/24
11	1	INSULATOR, DDC
12	1	INSULATOR, DDC
13	1	SCR. W/ CHROME PLATE
14	1	HAL, 2MM
15	1	SPACER, UEC-3
16	1	INSULATOR, 5W93
17	1	INSULATOR, 5W93
18	1	INSULATOR, 5W93
19	1	INSULATOR, 5W93
20	1	SCR. PAN/INT COVER
21	1	SCR. PAN/INT COVER
22	1	FRONT COVER, UEC
23	1	CONTROL BOX, UEC
24	2	LOC. W/ SHIELD TOOTH
25	1	LOC. W/ SHIELD TOOTH
26	1	LOC. W/ SHIELD TOOTH
27	2	HEX NUT
28	1	LOC. W/ SHIELD TOOTH
29	1	SCR. W/ SHIELD TOOTH
30	1	SCR. W/ SHIELD TOOTH
31	3	SCR. PAN/INT COVER
32	1	SCR. PAN/INT COVER
33	2	SCR. PAN/INT COVER
34	1	SCR. PAN/INT COVER
35	8	BRILLIANT FINISH FROM
36	1	BRILLIANT FINISH FROM
37	1	SCR. PAN/INT COVER

5

UEX Electronic Controller Installation

⚠ **WARNING:** Turn off all incoming power before installing or working on the UEX Electronic Controller. See additional safety precautions and practices in Section 2.

1. Remove the qty (2) screws mounting the Terminal Strip Assembly (pc# 3-2) to the Geared Limit Switch (pc# 2-13). These will not be reused. (See Figure 5.2)
2. Install the Encoder Drive Assembly (pc# 2-3) to the Geared Limit Switch (pc# 2-13) using the two Socket Head Cap Screws and Lockwashers (pc# 2-9, 2-10). (See Figure 5.1)
3. Reinstall the Terminal Strip Assembly (pc# 3-2) to the Geared Limit Switch (pc# 2-13) using the qty (2) Button Head Socket Cap Screws and Lockwashers (pc# 3-6 & 3-9). (See Figures 5.1 & 5.2)
4. Install the Encoder Mounting Plate Assembly (pc# 2-2) with Transformer (pc# 2-4) onto the Geared Limit Switch (pc# 2-13) using the qty (6) Button Head Socket Cap Screws and Hex Nuts (pc# 2-7, 2-8). (See Figure 5.1)

▲ **CAUTION:** Ensure proper clearance between the top gear of the Encoder Drive Assembly (pc# 2-3) and the mating bushing of the Encoder Mounting Plate Assembly (pc# 2-2). Add or remove Shims (pc# 2-11) to achieve 0.015" to 0.030" clearance.

NOTE: Lightly apply Lithium NLGI Grade #2 general purpose grease to all shafts, bushings and gear teeth of the Encoder Drive Assembly.

5. Connect the Primary leads (L1 & L2) and the Secondary leads (H1 & H2) to the matching terminals on the Terminal Strip Assembly (pc# 3-2). (See Figures 5.2 & 5.6)
6. Install the Power / Interface Board Assembly (pc# 3-1) onto the Electrical Compartment Mounting Plate (pc# 202) using the qty (5) Socket Head Cap Screws (pc# 3-4). (See Figure 5.2)
7. Connect the Power Board leads L1, L2, and L3 to the mating terminals on the Terminal Strip Assembly (pc# 3-2). (See Figure 5.6)
8. Connect the Power Board Motor leads T1 to T3 on the Terminal Strip. Connect T2 to T2 on the Terminal Strip and connect T3 to T1 on the Terminal Strip Assembly (pc# 3-2). (See Figure 5.6)

▲ **CAUTION:** Ensure that wire connections are as described in Step 8 to prevent incorrect rotation.

9. Install the Encoder Assembly (pc# 2-1) onto the Encoder Mounting Plate Assembly (pc# 2-2) using the qty (3) Socket Head Cap Screws (pc# 2-12). (See Figure 5.1)
10. Remove the Display Window Retention Plate (not shown) by removing the qty (4) Hex Head Self-Tapping Screws (pc# 204-4) from the Controls Compartment Cover (pc# 201-1). The Display Window Retention Plate will not be reused. Do not remove the Display Window (pc# 204-1), O-ring (pc# 204-3) or Gasket (pc# 204-6). (See Figure 5.3)

NOTE: Retain the qty (4) Hex Head Self-Tapping Screws (pc# 204-4) for use in the following step.

11. Install the Main Board Set Mounting Bracket (pc# 1-1) into the Controls Cover using the qty (4) Hex Head Self-Tapping Screws (pc# 204-4) previously used to mount the Display Window Retention Plate. (See Figure 5.3)
12. Connect the Main Board Interconnect Harness to the Main LCS Board (pc# 1-2) and then to the Interface Board (pc# 3-1-3). (See Figures 5.2 & 5.3)
13. Connect the Encoder Board (pc# 2-1) harness to the Main Board (pc#1-2) J-1 connector. (See Figures 5.1 & 5.3)
14. Install the Main LCS Board (pc# 1-2), with the Option Boards (pc# 1-3) if supplied, using qty (4) Pan Head Screws (pc# 1-4). (See Figure 5.3)
15. Connect the existing UEC-3 Harness to the Interface Board (pc# 3-1-3). (See Figure 5.2)

NOTE: If an existing CSE Control Station is being utilized, proceed with Step 16 to retrofit for the UEX Controls Package. Otherwise, skip to Step 19.

16. Remove the qty (4) Machine Screws and Lockwashers (pc# 3-7-28 & 3-7-29) and Printed Circuit Board (pc# 3-7-26) from the back of the CSE Control Station (pc# 3-7). (See Figure 5.4)
17. Connect the Jumper Wire (pc# 3-10) from the S1-1 to S2-1 switches. (See Figure 5.4)
18. Install the Printed Circuit Board (pc# 3-7-26) to the back of the CSE Control Station (pc# 3-7) using the qty (4) Machine Screws and Lockwashers (pc# 3-7-28 & 3-7-29). (See Figure 5.4)
19. Install the O-Ring (pc# 3-7-4) onto CSE Control Station (pc# 3-7) and slide the CSE into the Controls Compartment Cover, ensuring the knobs are oriented as shown in Figure 5.5. Mount using qty (4) Socket Head Cap Screws and Lockwashers (pc# 3-7-24, 3-7-25). (See Figure 5.5)
20. Connect the CSE Ribbon Cable to the Interface Board (pc# 3-1-3). (See Figures 5.2 & 5.5)
21. Connect the 120V cable from the Main Board Interconnect Harness to the Terminal Strip Assembly (pc# 3-2). (See Figure 5.6)
22. Attach one UEX Conversion Label (pc# 3-5) on the Power Board Assembly (pc# 3-1-2) side of the Power / Interface Board Chassis (pc# 3-1-1). Also attach one UEX Conversion Label (not shown) to the left of the existing unit nameplate on the gearbox. (See Figure 5.2)

Figure 5.1 - Encoder / MDPI / Transformer Installation

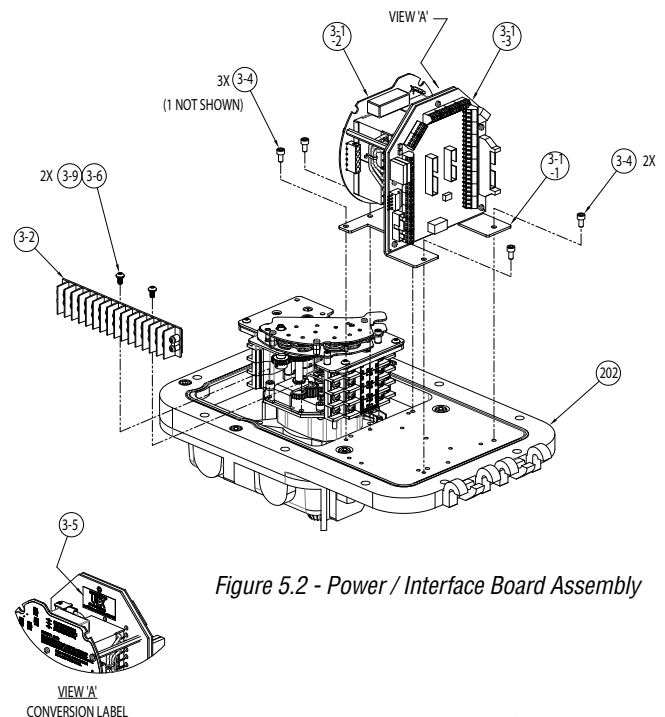
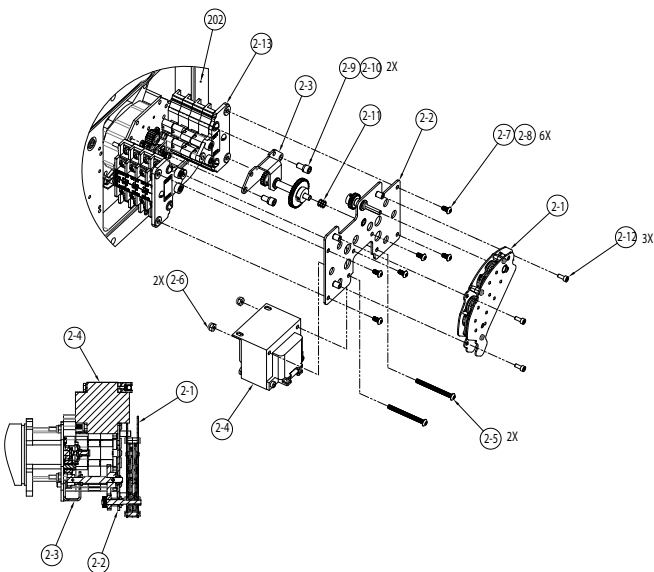

Figure 5.2 - Power / Interface Board Assembly

Figure 5.3 - Main Board Set Installation

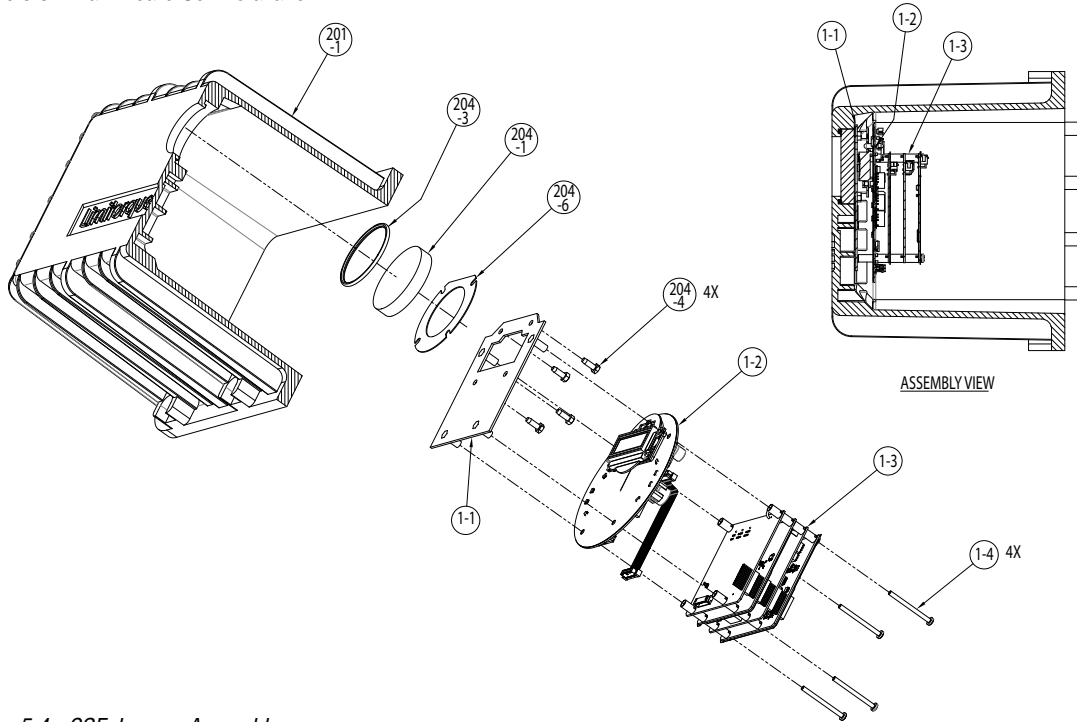

Figure 5.4 - CSE Jumper Assembly

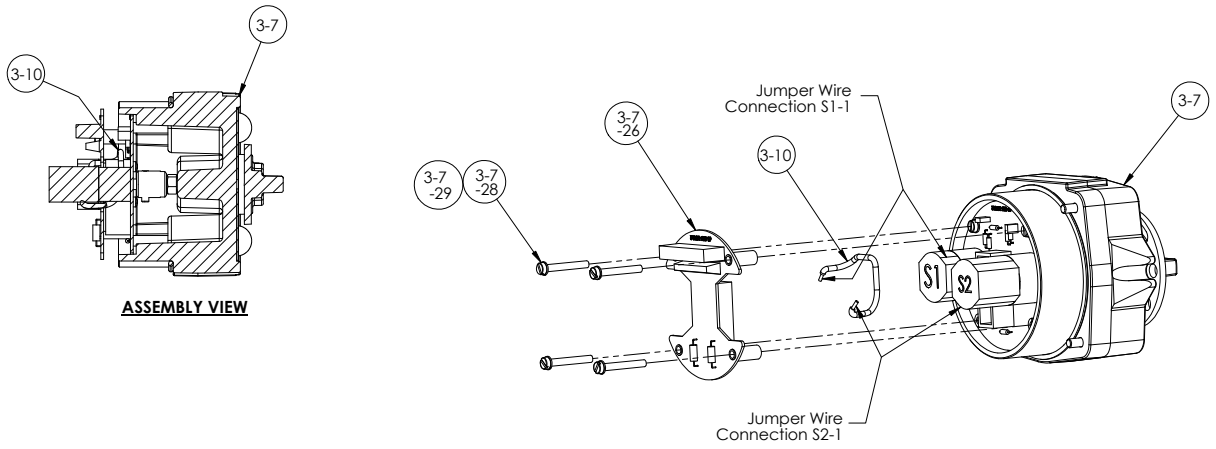

Figure 5.5 - CSE Control Station

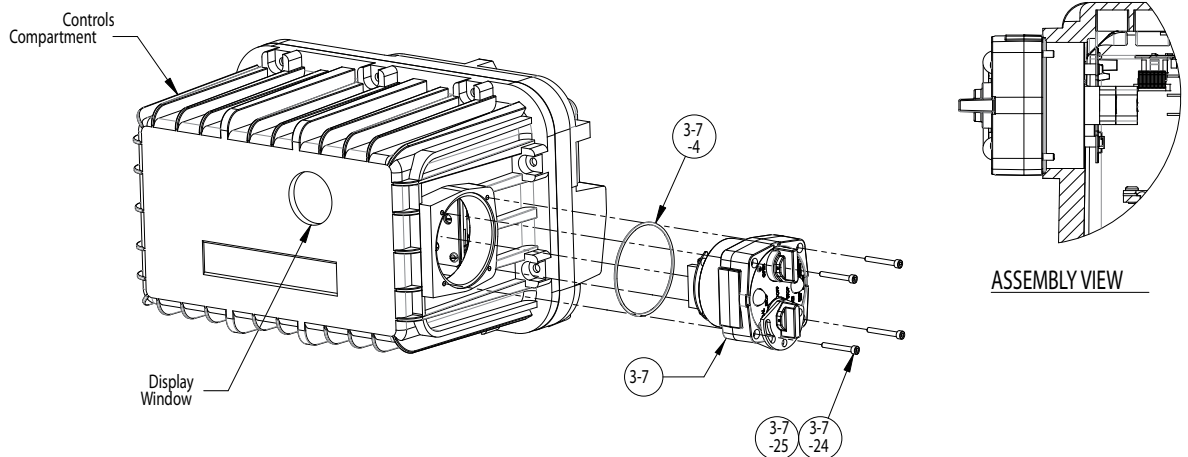

Figure 5.6 - Controls Compartment Assembly

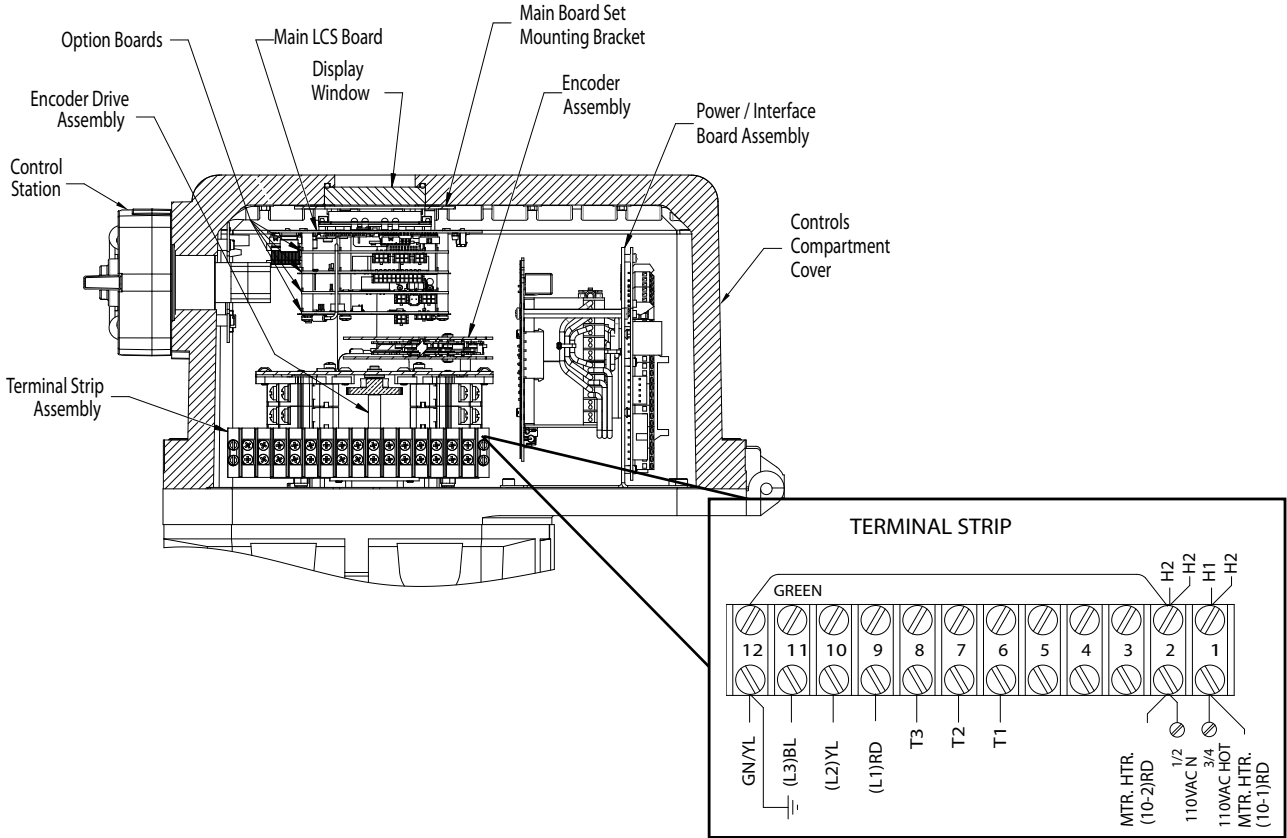

Table 5.1 – UEX Parts List

ITEM NO.	QTY.	DESCRIPTION
1-1	1	Mounting Bracket, Main Board Set
1-2	1	Main LCS Board
1-3	4 (Max)	Option Boards
1-4	4	Pan Head Screw
2-1	1	Encoder Assembly
2-2	1	Encoder Mtg Plate Assembly
2-3	1	Encoder Drive Assembly
2-4	1	Transformer
2-5	2	Button Head Socket Cap Screw
2-6	2	Hex Nut
2-7	6	Button Head Socket Cap Screw
2-8	6	Hex Nut (Not Shown)
2-9	2	Socket Head Cap Screw
2-10	2	Lockwasher
2-11	As Req'd	Shim
2-12	3	Socket Head Cap Screw
2-13	1	Geared Limit Switch Assembly

ITEM NO.	QTY.	DESCRIPTION
3-1	3-1-1	1 Power / Interface Board Chassis
	3-1-2	1 Power Board Assembly
	3-1-3	1 Interface Board
3-2	1	Terminal Strip Assembly
3-4	5	Socket Head Cap Screw
3-5	2	Uex Conversion Label (1 Not Shown)
3-6	2	Button Head Socket Cap Screw
3-7	1	Control Station
3-9	2	Lockwasher
3-10	1	Jumper Wire
201-1	1	Controls Compartment Cover
202	1	Electrical Compartment Mtg Plate
204-1	1	Display Window
204-3	1	O-Ring
204-4	4	Hex Head Self-Tapping Screw
204-6	1	Gasket

6

Standard Control Features

6.1 Basic Specifications

NOTE: The standard UEX controller wiring diagrams are shown in Section 15. Optional wiring diagrams are on subsequent pages. The most current wiring diagram is provided with the product. The following control features are included in the basic UEX controller.

For Optional Features, please refer to Section 8-Optional Control Features.

Figure 6.1 – UEX Local Control Panel

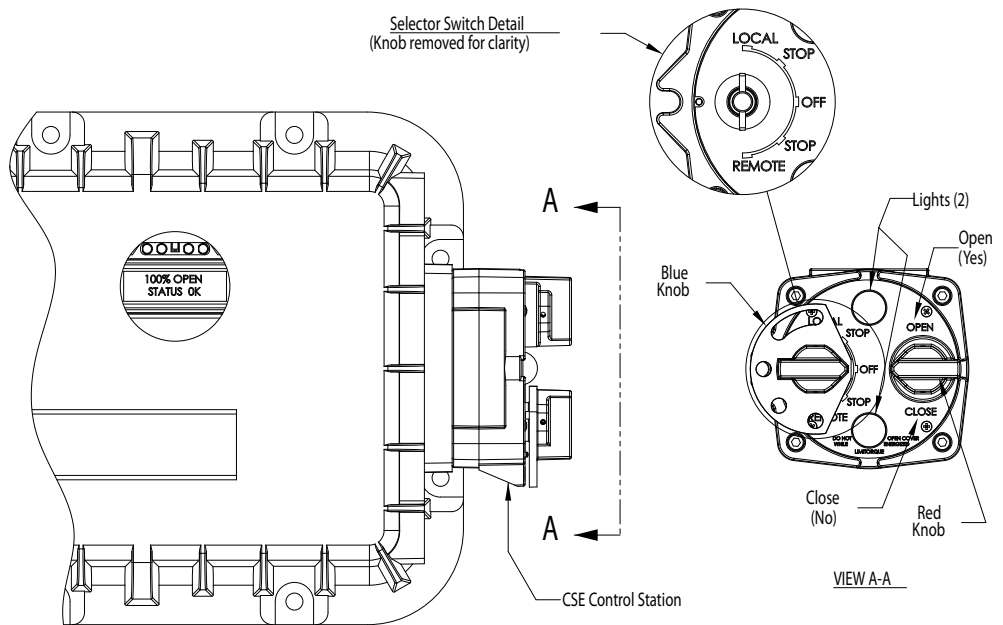

6.2 Local Control

The Control Panel includes a red Local/Stop/Remote selector switch (padlockable in all three positions; a ¼" (6 mm) hasp is recommended) and a black Open/Close rotary switch (spring-return to center). The Open and Close switches may be configured to allow either push-to-run (inching) control or maintained control.

Local Indication

The Control Panel includes the following:

- 32-character graphical LCD
 - Displays valve position as “PERCENT OPEN” and the current actuator status.
- Red/Green LED Indicators – the color assignment for the red and green LEDs is reversible as standard.
 - Red ON = Valve fully open
 - Red “BLINKING” = Valve opening
 - Green “BLINKING” = Valve closing
 - Green ON = Valve fully closed
- Yellow LED
 - Yellow ON = Actuator available for remote operation,
= Valve stopped in Intermediate position.
 - Yellow “BLINKING” = Monitor Relay de-energized, actuator not available for remote operation.

NOTE: For UEX packages supplied without the encoder, position indication on the LCD display or remotely is not available.

6.3 Remote Control Modes of Operation

The actuator may be controlled remotely by two, three or four wires.

- **Four-Wire Control** – Three momentary contacts. Valve can be opened, closed or stopped.
- **Two-Wire Control** – Single open or closed contact. Valve can be opened or closed, but not stopped in mid-travel.
- **Three-Wire Maintained** – Two momentary contacts for self-maintained control. Valve can be opened or closed but not stopped in mid-travel.
- **Three-Wire Inching** – Two “push-to-run” contacts. Valve can be opened, closed and stopped in mid-travel.

Refer to Figure 15.4 for remote wiring connections.

Remote Control Type

The actuator may be placed in digital only, modulation only, network only, or multi-command types.

- **Digital (Discrete) Only Control Type** – Only digital input commands are recognized and acted upon. All other types of remote control commands are ignored.
- **Analog (Modutronic) Only Control Type** – Only Modutronic 4-20 mA commands are recognized and acted upon. All other types of remote control commands are ignored.
- **Network Only Control Type** – Only network (DDC, Fieldbus, Profibus, Device Net) commands are recognized and acted upon. All other types of remote control commands are ignored.
- **Multi-control Mode Operation** - there are three modes of remote control when remote mode is configured for multi control: digital control, analog control, and network control. Digital and network control operation is based on the last command received. Analog operation is initiated by either toggling user input 2 (configure for CSE input) or breaking and reapplying the analog control.

Remote Control Signal Power

Power for remote control signals may be derived internally from the actuator or provided externally by the user. Signals can range from 24 to 125 VAC or VDC.

External Power Supply

An external power supply in the range of 12 to 24 VDC may be provided by the user with the optional UPS board.

Standard Internal Power Supply

The standard internal signal supply is 24 VDC. The 24 VDC supply offers a maximum loading of 5 W. The 24 VDC supply, in conjunction with the opto-isolated digital inputs, allows control from remote volt-free contacts over long distances and simplifies the user's control scheme. Standard control employs a negative earth. Positive earth (negative switching) is available by wiring to the (+) positive common as shown on the wiring diagrams.

6.4 Emergency Shutdown (ESD)

Up to three independent ESD signals may be applied, prioritized and configured for different actions for the ESD event associated with each. Either of these ESD signals may be applied to the actuator to override any existing command signal and send the valve to its preselected shutdown position, providing the actuator is in Remote mode (default configuration for ESD is "Ignore, take no action"). Any new command signal will be ignored until the ESD signal is removed. During setup, the actuator may be configured to close, open, stop, take no action, or "move to a previously configured position" on receipt of the ESD signal. The ESD action may also be configured to override any inhibit signal, the local selector switch, the local stop switch, an overtorque condition, lost phase, or jammed valve protection. Motor thermal protection may be bypassed for critical ESD applications in non-hazardous or special service locations. Disabling the motor thermostat voids all third-party certifications, including Factory Mutual and CSA.

6.5 Remote External Interlocks/Inhibits

Three user-defined inputs are provided for the connection of remote contacts that will prevent motorized operation of the actuator. These are effective in both Remote and Local modes and may only be overridden by a maintained ESD signal, if so configured (refer to Figure 15.1 for wiring connections). For ESD connections, the user may select either a single common or isolated commons.

6.6 Absolute Position Encoder

NOTE: For UEX packages supplied without the encoder, position indication on the LCD display or remotely is not available.

An absolute position encoder, incorporated into the L120 actuators, is the same as the encoder used in the MXa. It includes 18 phototransistors that are switched on and off by a gear/wheel mechanism. Valve position is sensed by an 18-bit, optical, absolute position encoder with redundant position sensing circuits designed for Built-In Self-Test (BIST).

Each of the position sensing circuits is redundant, facilitating BIST. The BIST feature discerns which failures will signal a warning only and require a warning plus safe shutdown of the actuator. Open and closed positions are stored in permanent, nonvolatile memory. The encoder measures valve position at all times, including both motor and handwheel operation, with or without power present, and without the use of a battery. The absolute encoder is capable of resolving $\pm 7^\circ$ of output shaft position and over 10,000 output drive rotations, however, in the L120, the encoder is limited to the maximum geared limit switch travel. Refer to Table 3.1.

This design permits continuous monitoring of valve position during motor and handwheel operation. The encoder is 100% repeatable and requires no backup power source for operation. The output is used to control the open and closed valve position and measure and report valve position, as well as provide local and remote position feedback.

The positioning accuracy is better than 99% for valves requiring 50 or more turns. For the maximum actuator turns and resolution, see Table 3.1.

Figure 6.2 – Absolute Position Encoder



18-bit optical, redundant position encoder provides continuous valve position monitoring without battery backup with Built-In Self-Test (BIST) capabilities.

7

Protection Features

7.1 Autophase Protection and Correction

The phase rotation of the incoming three-phase supply is continuously monitored. In the event that field wiring is reversed, UEX controls automatically correct to ensure the valve operates in the commanded direction. In addition, the detector circuit monitors the presence of all three phases. If a phase is lost, valve starting will be prevented and the user alerted via an LCD error message and Monitor Relay Alarm.

7.2 Jammed Valve Protection

If the actuator cannot overcome the required valve starting torque, a jammed valve condition occurs. Jammed valve protection senses the lack of valve movement and initiates a brief reverse/forward cycle to free the valve. If this is unsuccessful, further electrical operation is prevented and the monitor relay is signaled.

7.3 Instantaneous Reversal Protection

The control logic incorporates a brief time delay (from 0.5 to 1.0 seconds) between motor reversals. This reduces motor current surges and prolongs the life of the contactor. Note: It is not necessary to switch to STOP before reversing the actuator.

7.4 Motor Thermal Protection

The motor is protected against overheating by a thermal OL in the motor enclosure. Thermal cutout threshold is set for 120°C (Class B). Options are available for other classifications.

▲ **CAUTION:** Confirm that motor thermals are rated no higher than 120°C for Explosionproof service.

8

Optional Control Features

8.1 Modutronic

NOTE: For UEX packages supplied without the encoder, modulating control and position indication are not available.

The Modutronic controller will alter valve position in proportion to an analog command signal. It includes an automatic pulsing mode to reduce overshoot at the set point.

The following parameters may be easily set during the configuration of the unit:

- Proportional Band range from 2% to 100% (15% = default)
- Dead Band range from $\pm 1\%$ to 50% (2% = default)
- Polarity 20 mA = OPEN (default) or 20 mA = CLOSE
- Action on loss of command signal OPEN, CLOSE, STOP (CLOSE = default), or Move-to a previously configured position
- Delay after stop 0–60 seconds (0 = default)
- Command Signal
 - 4–20 mA
 - Input impedance - 150 ohms

Repeatability – The Modutronic is repeatable to within $\pm 1\%$ for 60 seconds stroke time or longer, and 2% for 30 to 60 seconds.. Repeatability is defined as encoder feedback position versus position command. Overall valve and actuator system accuracy depends on many factors, including actuator gearing backlash and valve/actuator coupling tolerance, and therefore cannot be defined by this document.

Extrema Mode – If the command signal represents a position of 0–2% OPEN (nominal 4.00–4.32 mA) or 98–100% OPEN (nominal 19.68–20.00 mA), then the UEX/L120 will move the valve directly to that position, without pulsing.

Positioning Frequency – The standard frequency is suitable for a rate of 600 starts/hour for short periods, typical of process start-up. Typical process control of ≤ 100 starts/hour.

8.2 Analog Position Transmitter (APT)

The APT is an internally powered, non-contacting valve position transmitter. The isolated output signal is proportional to the position of the valve and is available as 4–20 mA and/or 0–20 mA, 0–10 VDC, 2–10 VDC, 0–5 VDC, or 1–5 VDC.

The user may select the minimum signal to represent either the fully OPEN or the fully CLOSE position of the valve during the setup procedure.

- Accuracy = 99% of full scale value (for Drive Sleeve Turns > 50)
- Non-Linearity = $\pm 1\%$ of full scale value
- Impedance = 0–600 ohms (4–20 mA signal)
- Minimum external load = 1000 ohms (0–10 VDC signal)

8.3 Two-Speed Timer

A two-speed pulsing timer can be enabled to extend the operating time in the close and/or the open directions. Pulsing may be applied from 0.5 (if precision is set to xxx.x%) to 99% of full valve travel or to a small portion. The ON pulsing cycle is configurable from 0.5 to 20 seconds in 0.5 second increments, and the OFF pulsing cycle is configurable from 1.0 to 200 seconds in 1 second increments. The two-speed timer is especially effective where concerns of hydraulic shock exist.

8.4 Control Station (CSE)

The CSE is a separate control station designed for the operation of inaccessible actuators. It is available with LEDs, Remote/Local and Open/Close selector switches. The CSE may be powered by the actuator internal supply, provided wire resistance and other external loads do not limit the available signal power presented to the UEX.

9

Network Communications

The UEX provides a comprehensive network option portfolio to the user. Network solutions are improved for the user that has an L120 with UEC, with the addition of DeviceNet to complement Modbus, FOUNDATION Fieldbus H1, Profibus DP_V1 and Profibus PA. UEX provides the user with predictable, reliable, and safe operation for years to come, in applications which are subject to the most rigorous requirements and environmental extremes.

With each of the provided network protocols a user may configure the unit to move to a predefined fail-safe position on loss of communication. Action on loss of command signal OPEN, CLOSE, STOP, or MOVE-TO preconfigured position. The user may also configure the length of time communication must be lost before the unit indicates communication loss and performs the communication loss action.

NOTE: For UEX packages supplied without the encoder, network control and position indication are not available.

9.1 Modbus™

Modbus™ provides the ability to control and monitor up to 250 actuators over a single twisted-pair cable. The communication network employs Modbus™ protocol on an RS-485 network and is redundant. Redundancy assures that any single break or short in the communication cable will not disable any actuators. Each actuator has included an addressable field unit that communicates over the twisted pair network and executes open, close, stop, ESD, and GO TO position commands. The field unit also communicates all actuator status and alarm diagnostic messages over the same communication network.

Modbus Network

- Single-ended loop (as standard – See Figure 16.1)
- Modbus protocol
- High speed – up to 19.2K baud

9.2 Master Station III

L120 actuators equipped with Modbus can be controlled via Flowserve Limitorque's Master Station II or III.

The next-generation master station is designed specifically for use with Limitorque's line of DDC (Modbus) electric actuators. The Master Station III acts as a single-source controller for up to 250 actuators.

The Master Station III is a plug-and-play solution that provides complete control and diagnostics for Limitorque field units through a simple touch-panel operator interface. The key features of the Master Station III include:

- A network time protocol to allow for time synchronization of alarms/diagnostic data to Host device
- Multilingual support includes English, Spanish, German, French, Italian
- Asset management and diagnostic via Bluetooth V2.0+ Enhanced Data Rate (EDR) Class 100m
- Configuration of slave register polling schedule
- Industry standard Modbus RTU, ASCII, UDPor TCP/IP protocols
- Three levels of user password protection
- 5.6" TFT touch-screen display
- E-mail notification of configurable alarm conditions
- Data/event logging
- Network control of up to 250 devices
- Front access to peripheral ports: Ethernet, USB x 2, VGA, printer/debug
- Modular hot-swappable redundant design
- Built-in secure Web server for control, monitoring and asset management capabilities

9.3 FOUNDATION Fieldbus Communication

L120 actuators can be fitted with FOUNDATION Fieldbus protocol that complies with the IEC 61158-2 Fieldbus H1 standard. The field unit device is able to support several topologies, such as, point-to-point, bus with spurs, daisy chain, tree, or a combination of these. The FF device has network features that include:

- Link Active Scheduler that controls the system
- High-speed communications at to 31.25 kbits/sec
- Publisher - subscriber communication
- One analog input block, one analog output block, two discrete output function blocks, Transducer block, Resource block, and four discrete input function blocks
- PID (proportional integral derivative) loop control
- Device descriptions
- Configurable by user

Link Active Scheduler communication: Fieldbus segments have one active Link Active Scheduler (LAS) at a given time, which is the bus arbiter, and does the following:

- Recognizes and adds new devices to the link
- Removes non-responsive devices from the link
- Schedules control activity in, and communication activity between, devices
- Regularly polls devices for process data
- Distributes a priority-driven token to devices for unscheduled transmissions

9.4 PROFIBUS DP V1 Communication

L120 actuators can be fitted with Profibus DP_V1 protocol field units that comply with EN50170 Fieldbus Standard for RS-485 communications. The device supports several topologies, such as, point-to-point, bus with spurs, daisy chain, tree, or a combination of these. The PB device has network features that include:

- High-speed communications up to 1.5 m/bits/s
- Master-to-slave communication
- One analog input block, one analog output block, two discrete output function blocks, Transducer block, Physical block, and four discrete input function blocks
- Device descriptions configurable by user

High-Speed Data Exchange – Startup Sequence

- Power ON / Reset – Power On / Reset of master or slave
- Parameterization – download of parameters into field device (selected during configuration by the user)
- I/O Configuration – download of I/O configuration into the field device (selected during configuration by the user)
- Data Exchange – cyclic data exchange (I/O Data) and field device reports diagnostics
- Also supports Profibus_DP redundancy

9.5 PROFIBUS PA Communication

A Profibus PA protocol is available and complies with EN50170 Fieldbus Standard and Fieldbus physical layer per IEC 61158-2 for communications. The device supports several topologies, such as point-to-point, bus with spurs, daisy chain, tree, or a combination of these. The PB device has network features that include:

- High-speed communications at to 31.25 kbits/s with Manchester coding
- Master-to-slave communication
- Bus powered for 9-32 VDC and 15 mA per actuator
- Stand-by communication channel
- One analog in and one analog out, four digital input and up to eight digital output function blocks
- Device descriptions configurable by user

9.6 DeviceNet

DeviceNet complies with CAN based protocol and provides the following features:

- DeviceNet Group 2 Server implementation.
- Bus Powered Network Interface allows power alarm information to be communicated when actuator loses main power. The actuator does NOT drop off the network when 3-phase power is lost.
- Standard Polled I/O Connection
- Standard Bit Strobed I/O Connection
- Standard Change of State / Cyclic I/O Connection
- Standard explicit connections defined as:
 - Various Assembly Objects and sizes that allow the network user to determine how much data to transfer to accommodate network installation data throughput requirements.
 - Automatic BAUD rate detection.
 - Node Address configurable via local setup menu, or via the remote network user.
 - Broadcast or group network originated ESD support.

The following commands and information may be transmitted over the DeviceNet network:

- “OPEN,” “STOP,” and “CLOSE” commands
- “ESD” and “MOVE-TO” position commands
- Actuator status and alarm messages
- Four digital inputs, two digital outputs, one analog input and one analog output for user configuration
- A surge-protected and isolated communication channels
- UEX control panel configuration

Please see Section 16 for network connection topologies and cabling recommendations.

10 Monitoring and Diagnostic Features

10.1 Local Features

LCD Displays – The LCD displays an array of data concerning the status of actuator components in clear, graphical or textual language. The UEX is available with eleven languages: English, Spanish, German, French, Italian, Portuguese, Mandarin, Russian, Bahasa Indonesia, Turkish and Katakana.

Normal Display – The normal display illustrates current valve position and status.

Alarm Functions – Alarm functions (active alarms will be toggled every four seconds) that may be displayed include:

- Valve Jammed - Valve cannot start moving
- Lost Phase - One of three phases lost
- Motor Overtemp – Thermal overload exceeded
- Overtorque - Torque exceeded in mid-travel
- Hardware Failure - Indication
- Modbus, Profibus, FOUNDATION Fieldbus, DeviceNet off - Enabled, but “OFF”
- ESD Active - ESD signal active
- Inhibit Active - Inhibit signal present
- No analog signal - 4–20 mA signal absent (Modutronic enabled, red selector switch in “REMOTE”)
- DDC, PB, FF, DNet comm. Loss – Enabled, signal absent
- Analog Output Loss - Enabled, but output current loop open

10.2 Diagnostics

Standard Diagnostic Screens – Diagnostic screens may be accessed quickly through the Setup dialogue or the UEX Dashboard Software solutions package. These screens provide detailed data of actuator status. Included are:

- **Hardware** – status of electronic components such as thermistor, encoder, power board, DDC/FF/PB/DeviceNet network board, analog board, DIGIN and ANIN (digital in and analog in)
- **Motor** – Phase rotation
- **Power Supply** – Maximum and minimum voltage, frequency
- **Identification** – Tag number, serial number, order number, software revision
- **View Network Status** – Checks for Standby, Recoverable Fault, Nonrecoverable Fault, and View Network Status
- **Operation Log** – Actuator turns, contactor operations, motor run-time, stroke time, manual operations
- **View Control Compartment Temperature (View Power Supply Menus)**

Figure 10.1 – Normal and Diagnostic Displays

Normal Display - STATUS OK confirms that the actuator is suitable for remote operation.

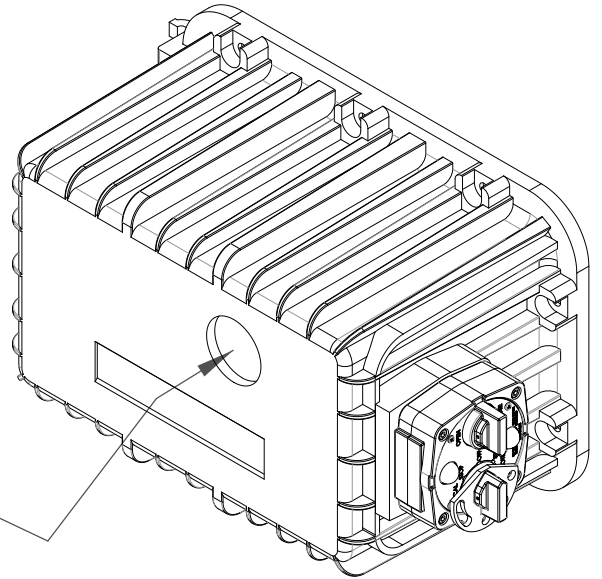
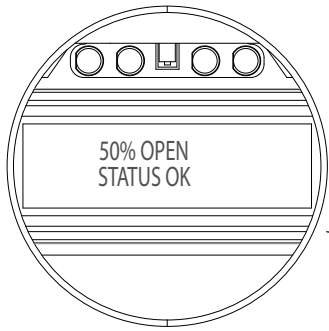

Normal Display/Alarm Condition - If the actuator is not suitable for remote operation, the appropriate alarm will be shown.

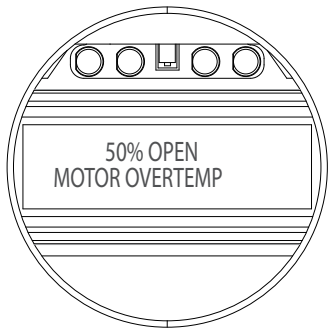

Diagnostic Display informs user of failed hardware.

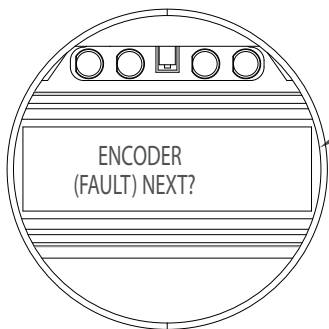

Typical Display

11

Remote Indication Features

11.1 Actuator Status Contacts (S1a, S1b, S2a, S2b)

Four latched contacts provide remote feedback of actuator status. Two (S1a, S2a) contacts may be individually configured for normally open, normally closed, or blinker (continuous opening and closing of the valve) operation and provide feedback of one of the functions listed below. Two other relays are complementary.

- | | |
|--------------------|-----------------------|
| • Closed | • Motor overtemp |
| • Closing | • Overtorque |
| • Mid-travel | • Open torque switch |
| • Opening | • Close torque switch |
| • Open | • ESD signal |
| • Stopped | • Open inhibit |
| • Valve moving | • Close inhibit |
| • Local selected | • Lost phase |
| • Local STOP/OFF | • No analog signal |
| • Manual operation | • Hardware failure |
| • Valve jammed | • Network controlled |
| • Remote selected | • CSE controlled |

Recommended settings are:

- S1a – Normally closed contact at valve fully CLOSE
- S1b – Normally closed contact at valve fully OPEN – Default position. See wiring diagram.
- S2a – Normally open contact at valve fully CLOSE
- S2b – Normally open contact at valve fully OPEN – Default position. See wiring diagram.

The standard contacts are rated for 2.0 A at 30 VDC and 0.5 A at 125 VAC.

11.2 Monitor Relay (RM)

The monitor relay provides immediate indication of problems that prevent remote valve operation. It has a normally open contact and a normally closed contact (1 x SPDT contact) and is energized when the three-phase supply is present and the actuator is in a normal/healthy state.

The relay will de-energize if any of the following events occur:

- Loss of one or more phases of the three-phase power supply
- Loss of internal control supply
- Jammed valve detected
- Motor overtemp is active (unless thermostat is configured to OFF)

During configuration, the following parameters may be added to the monitor relay function:

- Selector switch is in “Local” mode
- Selector switch is in “Stop” position
- Overtorque
- Inhibit signal active
- ESD signal active (The user can enable or disable “local” mode and “stop” position. Default is enabled.)

The monitor relay resets when the faulty state is rectified. The standard contacts are rated for 5.0 A at 250 VAC, 30 VDC. The monitor relay can be disabled if the user chooses.

11.3 Exact End Position Indication

On torque-seated valves, the end-of-travel indication switch trips when the required torque is achieved at the end of travel. This ensures that remote, self-latched signals will not be disconnected prematurely, and that the valve will be tightly seated.

12 Auxiliary Power Supply - Uninterruptible Power Supply (UPS) Connection

If the main three-phase power supply is not available during the configuration of the actuator, an optional module contains provisions for connecting a 24 VDC, 1 A power source to the auxiliary input terminals shown in the wiring diagram on the following pages. Power supply will draw up to 0.5 A.

13 Isolated Commons

The UEX is provided with isolated commons for control functions. Please refer to wiring diagram in Section 15 for locations.

14 Actuator Configuration

14.1 Local Configuration

UEX controllers may be configured through the CSE control station switches, with settings visible on the LCD display. Settings that can be initiated or changed include:

- Direction of rotation
- Action on ESD
- External inhibits
- Remote control operating mode
- Motor thermostat action
- Stop valve on torque or position
- All optional features (Modutronic, Modbus, FF H1, PB-DPV1, PB-PA, DeviceNet, Timers, APT, etc.)

14.2 Default Configuration

Unless otherwise specified, UEX controllers will be shipped with the following configuration, which becomes effective after the L120 limit switches are properly set.

- Open stop by limit
- Close stop by limit
- Maintained local controls
- Clockwise to close
- ESD is “off” and set to “IGNORE.”
- Inhibits enabled, turned “OFF”
- Remote control – three-wire maintained and Multi-mode
- Password – 100
- Modutronic Option (if installed)

Table 14.1 – Default Configuration Guidelines

<p>Modutronic Option Proportional band – 15% Deadband – 2% Polarity – 20 mA = Open Action on loss of signal = Close</p>	<p>Modbus RTU protocol 9600 baud Analog scale = 0-100 Proportional band – 15% Deadband – 2% Offset – 0 mA</p>
<p>FF Option, DeviceNet and PB Option Analog scale = 0-100 Proportional band – 15% Deadband – 2%</p>	

Figure 14.1 – Configuring the UEX Controller

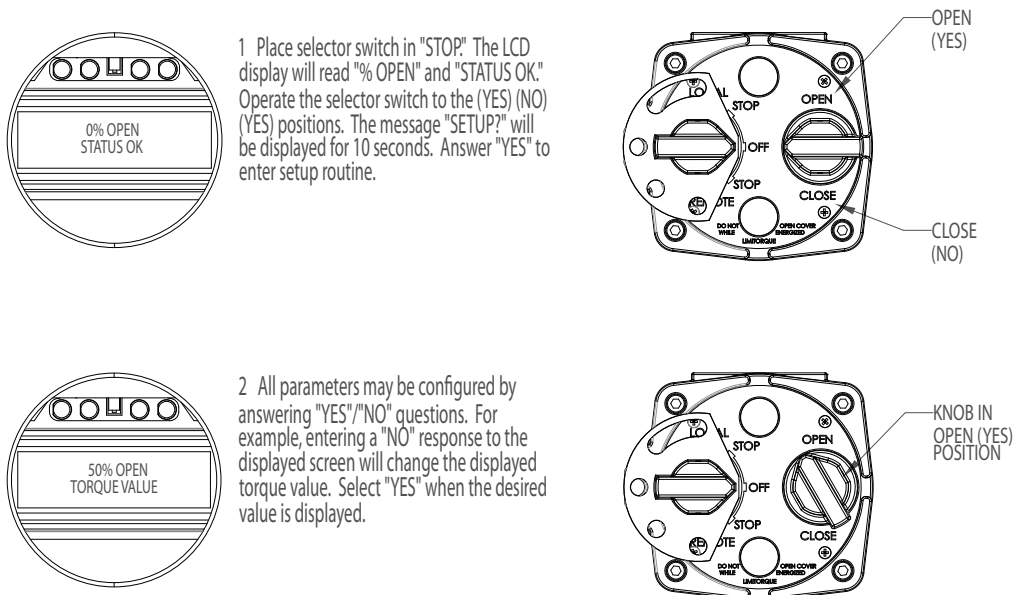

Configuration screens are displayed in English. Languages such as Spanish, French, German, Italian, Portuguese, Mandarin, Russian, Bahasa Indonesia, Turkish and Katakana are also available and can be configured via the actuator control panel.

A three-digit numeric password is included as part of the initial setup procedure to prevent unauthorized changing of the configured parameters. If the password is entered incorrectly, settings may be viewed, but not changed. The default value for the password is 100.

14.3 Setup Menus

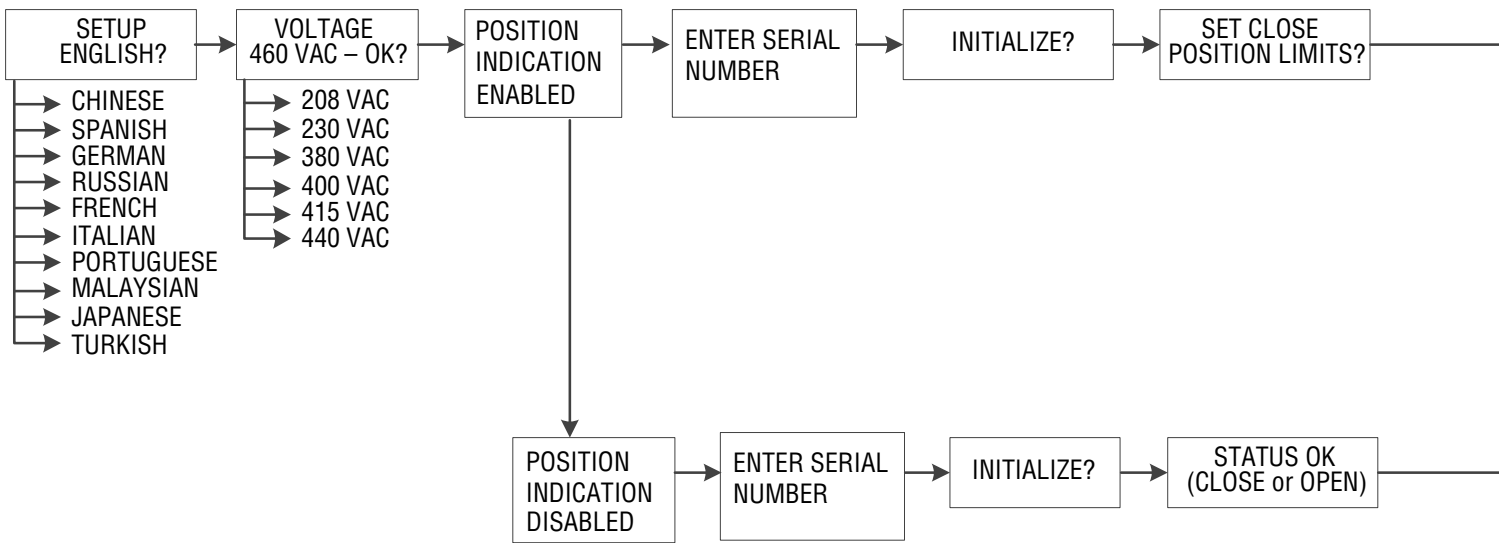

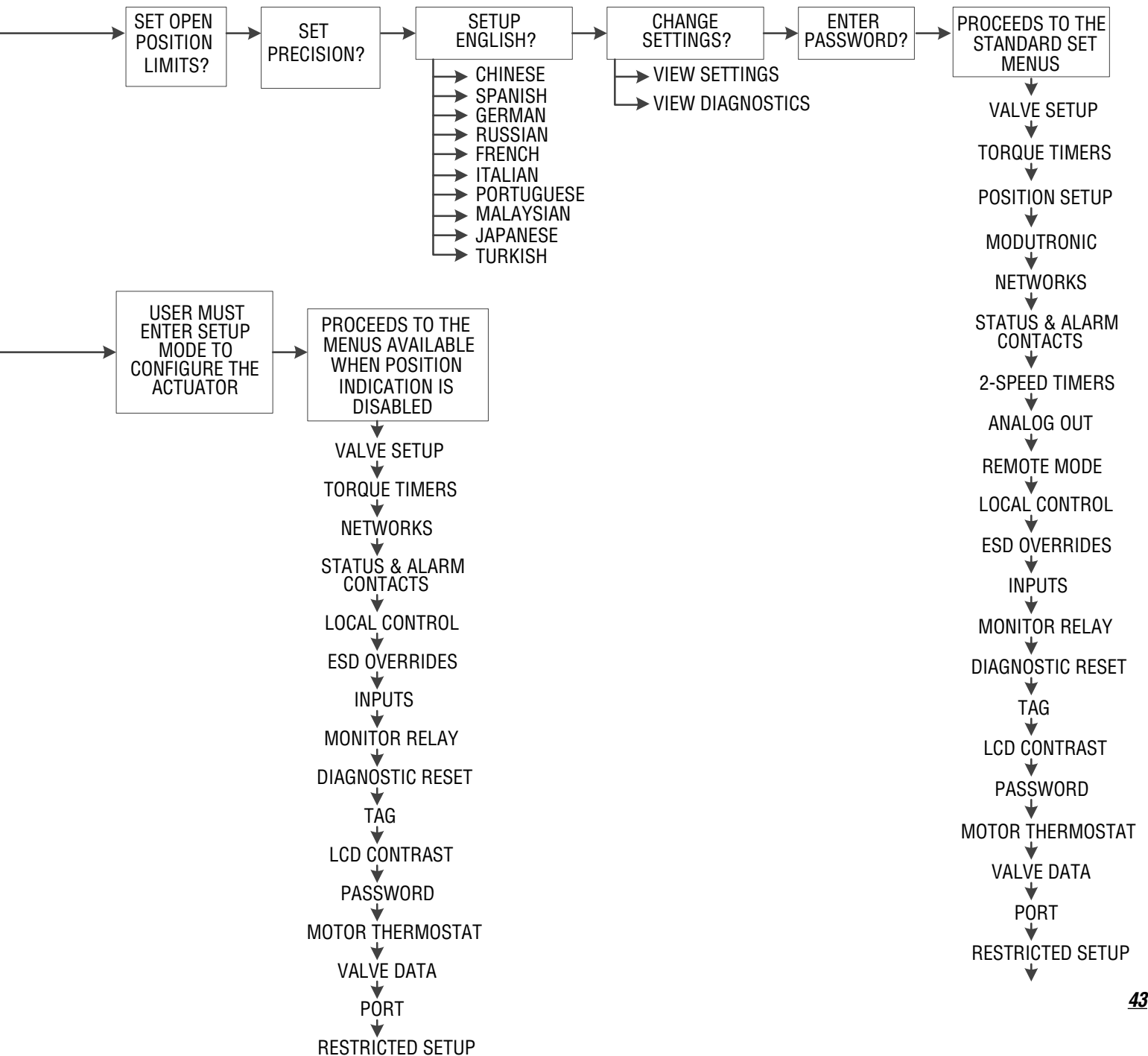

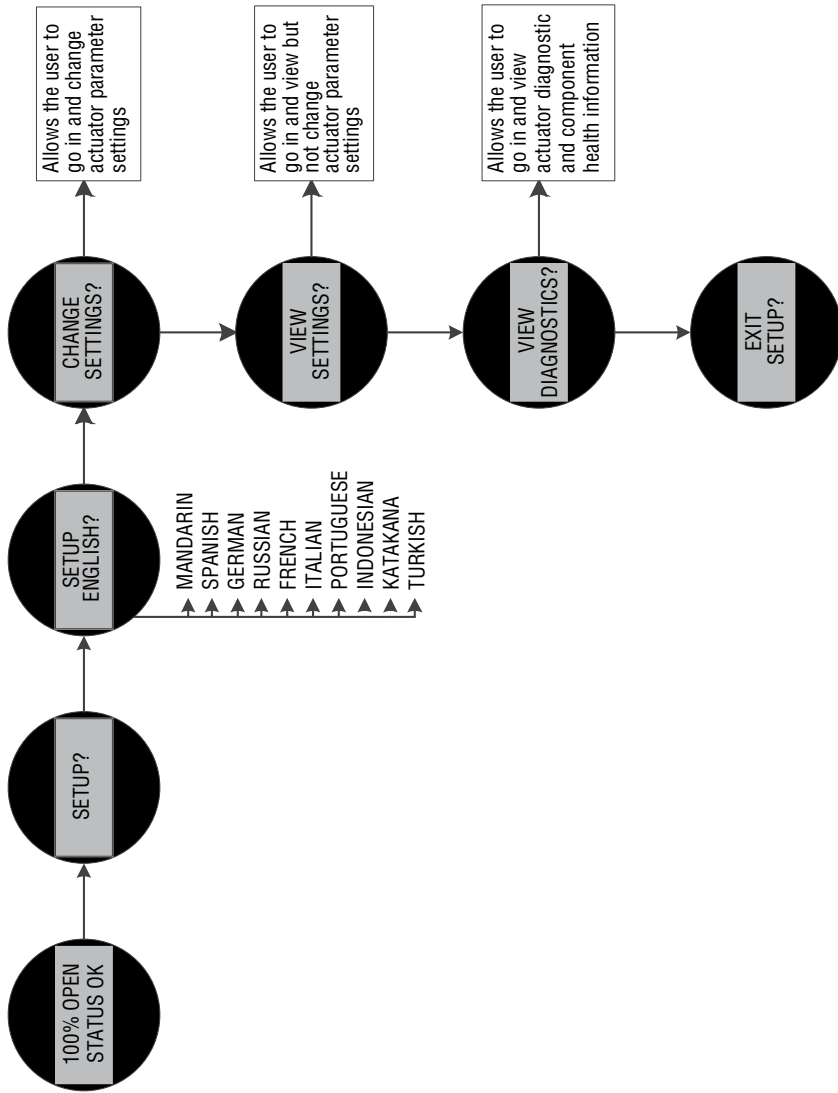

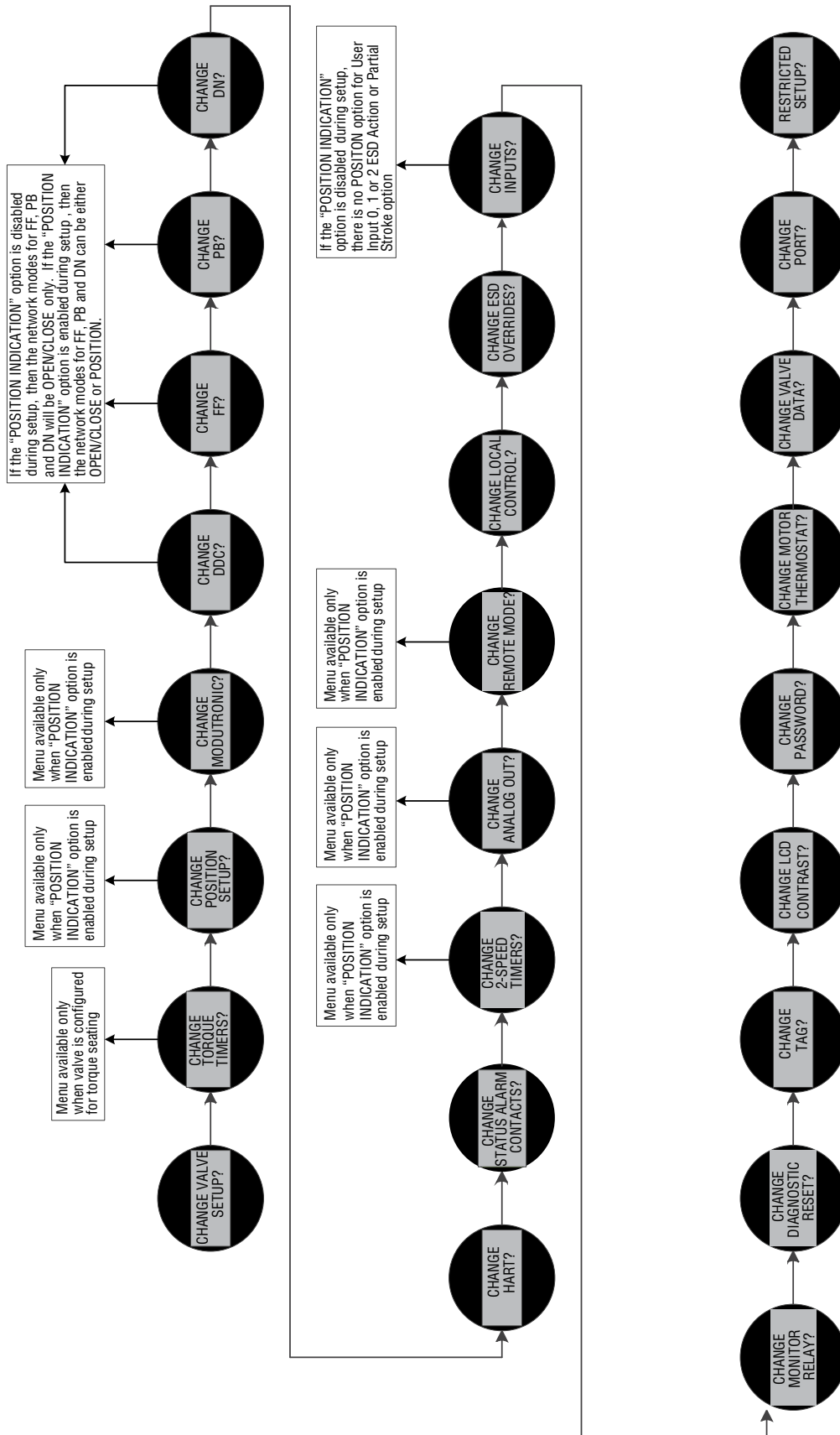

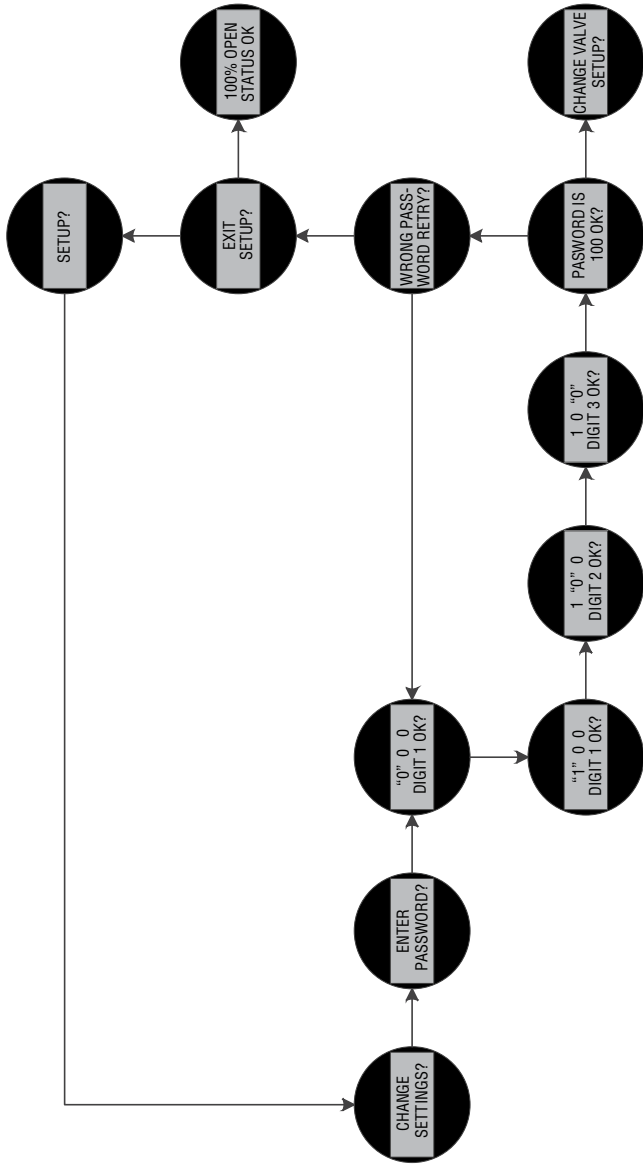

Change Valve Setup: Allows the user to configure the actuator closing direction and how the valve is seated

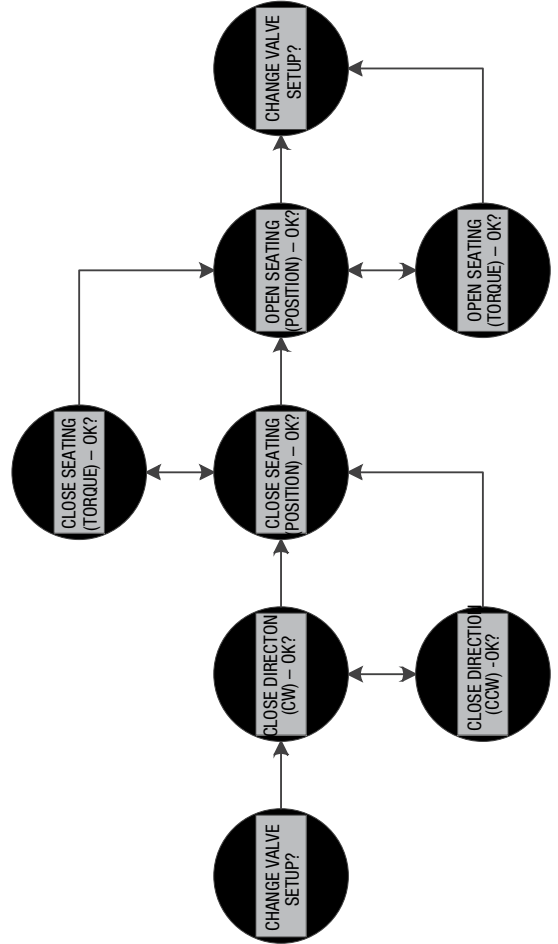

Change Torque Timers: Allows the user to configure the actuator open and close torque timers. This menu is only available to the user when the actuator is configured for OPEN and/or CLOSE Torque Seating

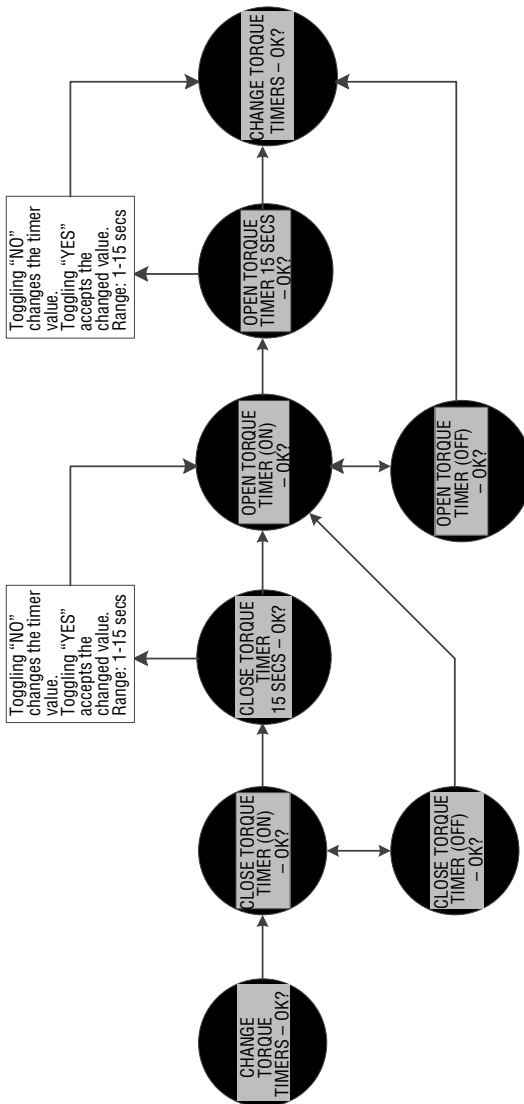

Change Position Setup: Allows the user to set the OPEN and CLOSE encoder limits based on the geared limit switch settings

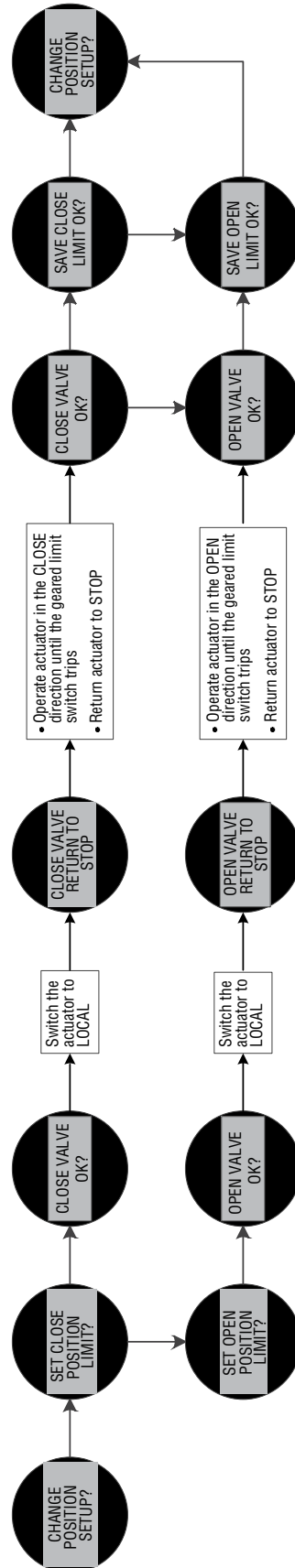

Change Modutronic: Allows the user to configure the actuator to be controlled with a 4-20 mA input signal

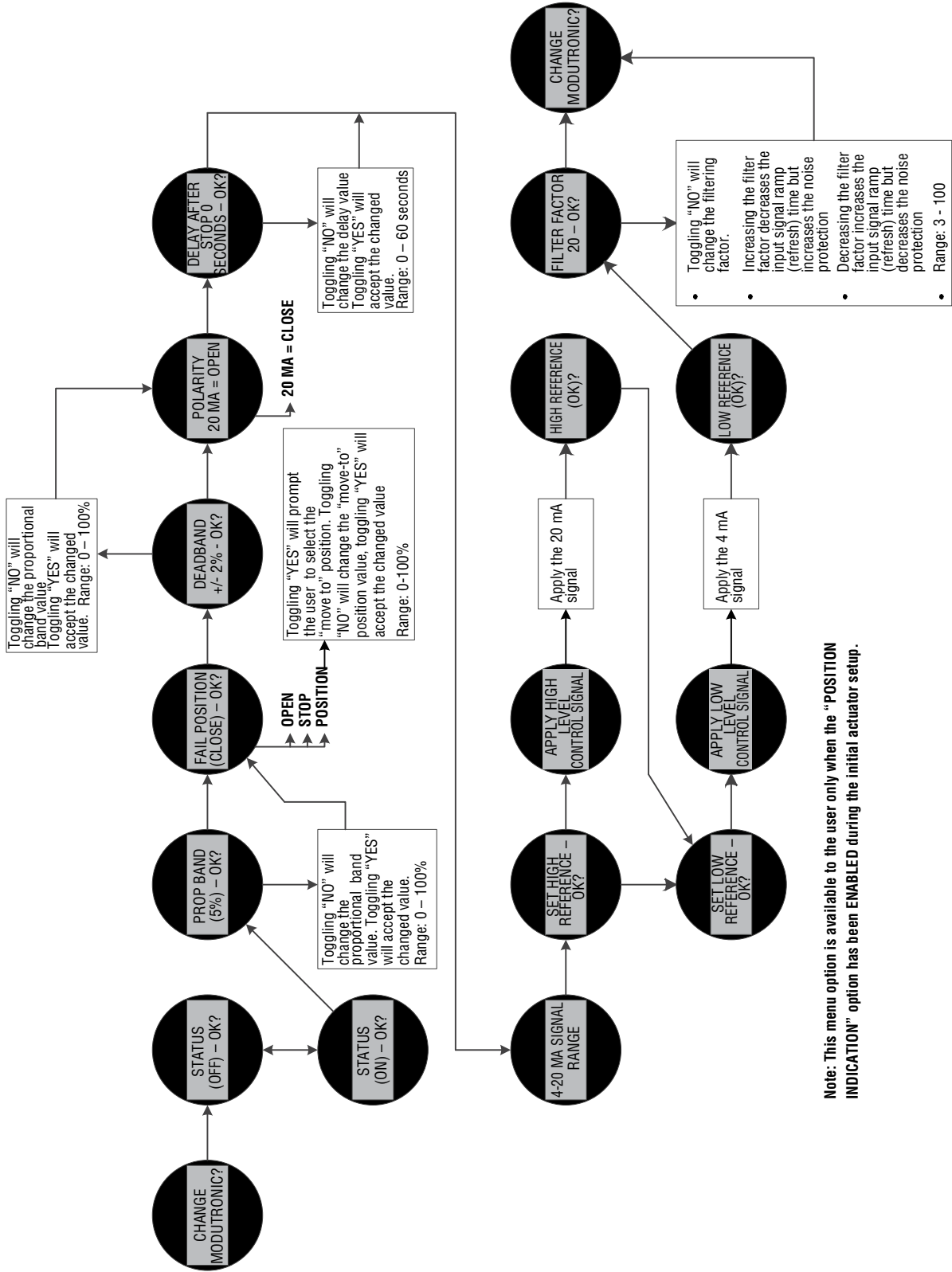

Change DDC: Allows the user to configure the actuator to be controlled over a Modbus network

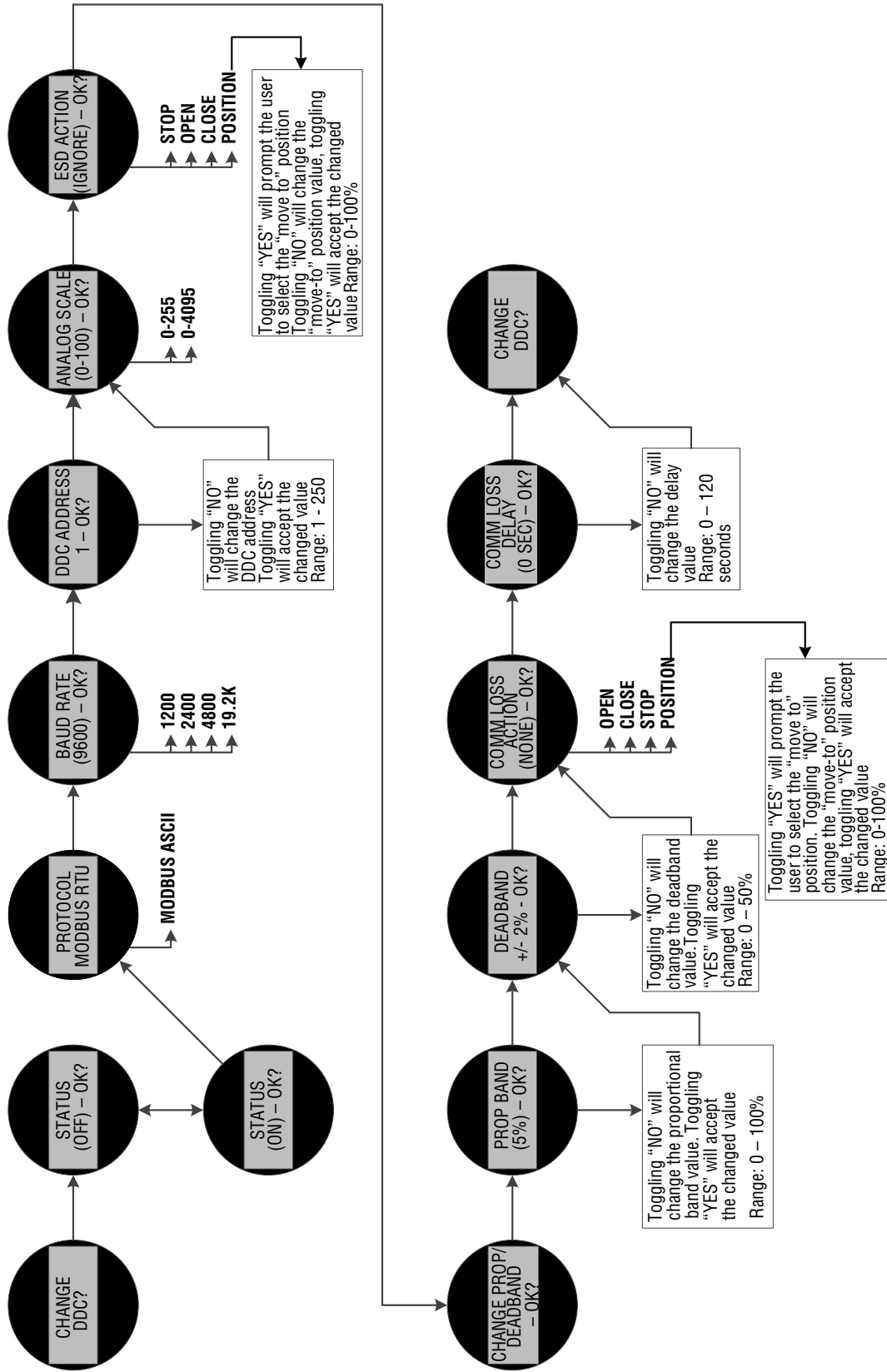

Note: If the "POSITION INDICATION" option is disabled during setup, then there will be no POSITION option in either the ESD Action menu or the Comm Loss Action menu.

Change FF: Allows the user to configure the actuator to be controlled over a Foundation Fieldbus network

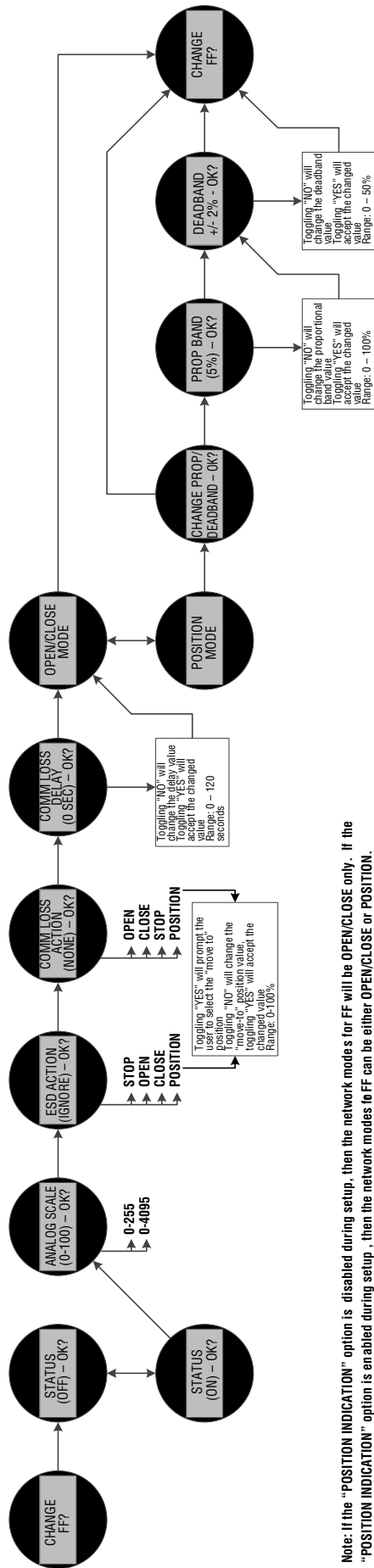

Note: If the "POSITION INDICATION" option is disabled during setup, then the network modes for FF will be OPEN/CLOSE only. If the "POSITION INDICATION" option is enabled during setup, then the network modes for FF can be either OPEN/CLOSE or POSITION.

Change PB: Allows the user to configure the actuator to be controlled over a Profibus network

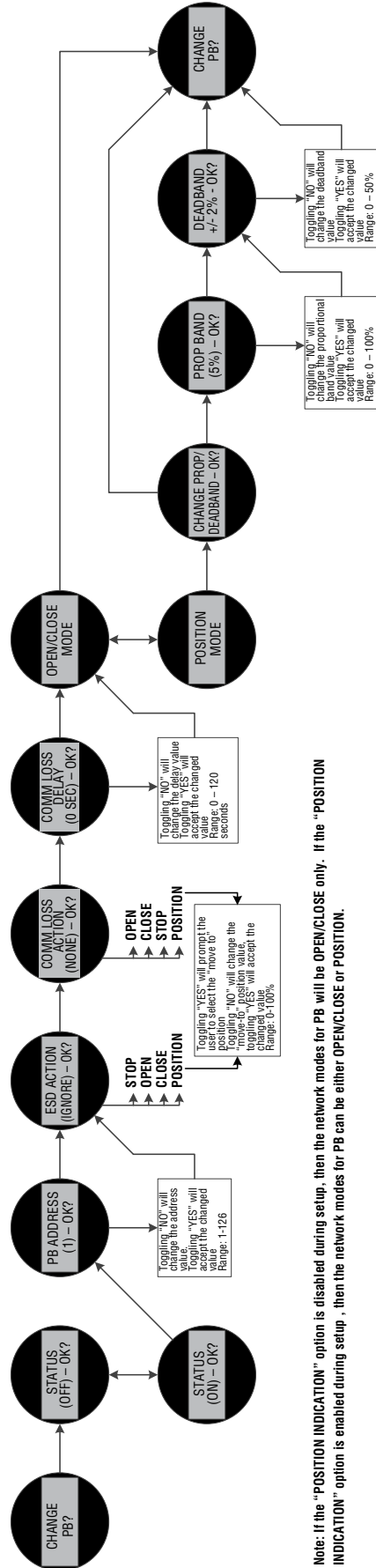

Note: If the "POSITION INDICATION" option is disabled during setup, then the network modes for PB will be OPEN/CLOSE only. If the "POSITION INDICATION" option is enabled during setup, then the network modes for PB can be either OPEN/CLOSE or POSITION.

Change DN: Allows the user to configure the actuator to be controlled over a DeviceNet network

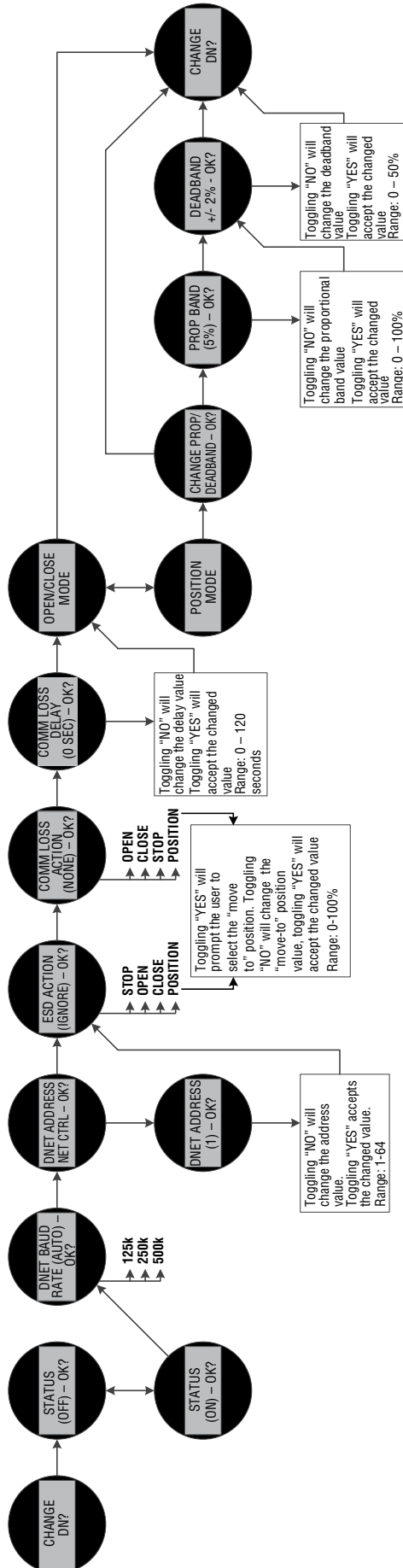

Change HART: Allows the user to configure the actuator to be controlled by a HART controller

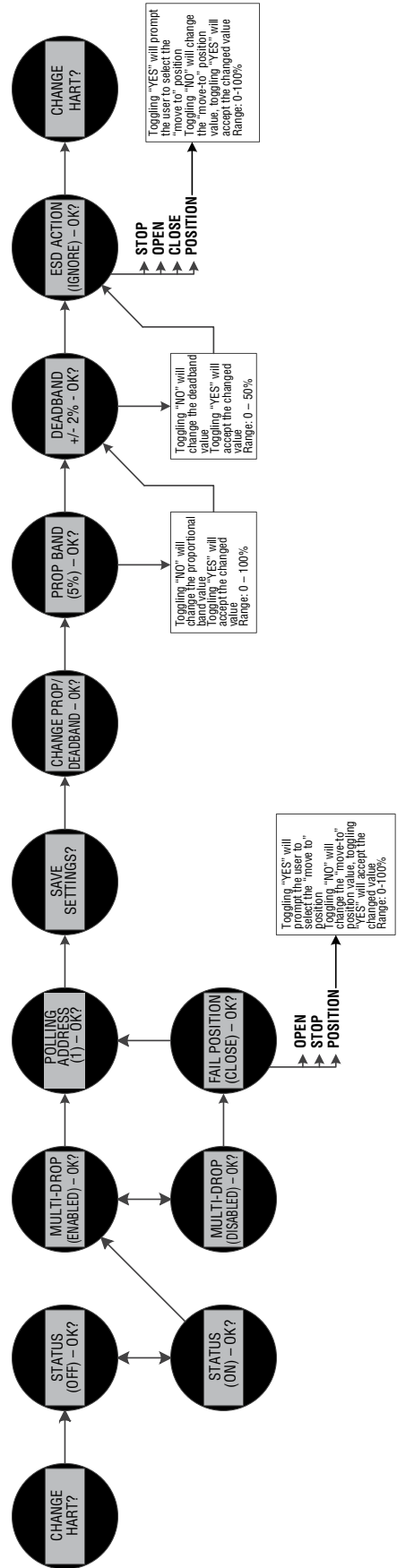

Change Status and Alarm Contacts: Allows the user to configure the status and alarm contacts

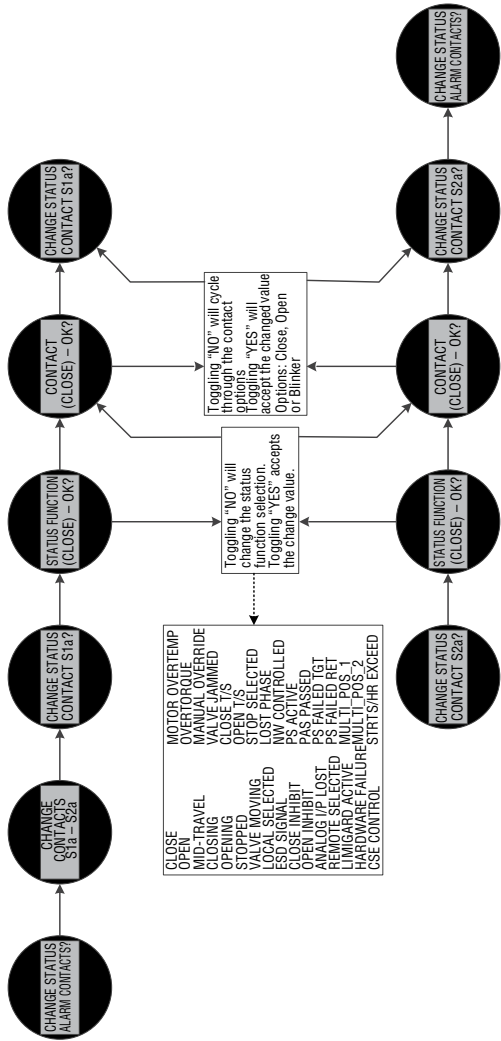

Change 2-Speed Timers: Allows the user to configure the OPEN and/or CLOSE 2-speed timers to increase the actuator operating time

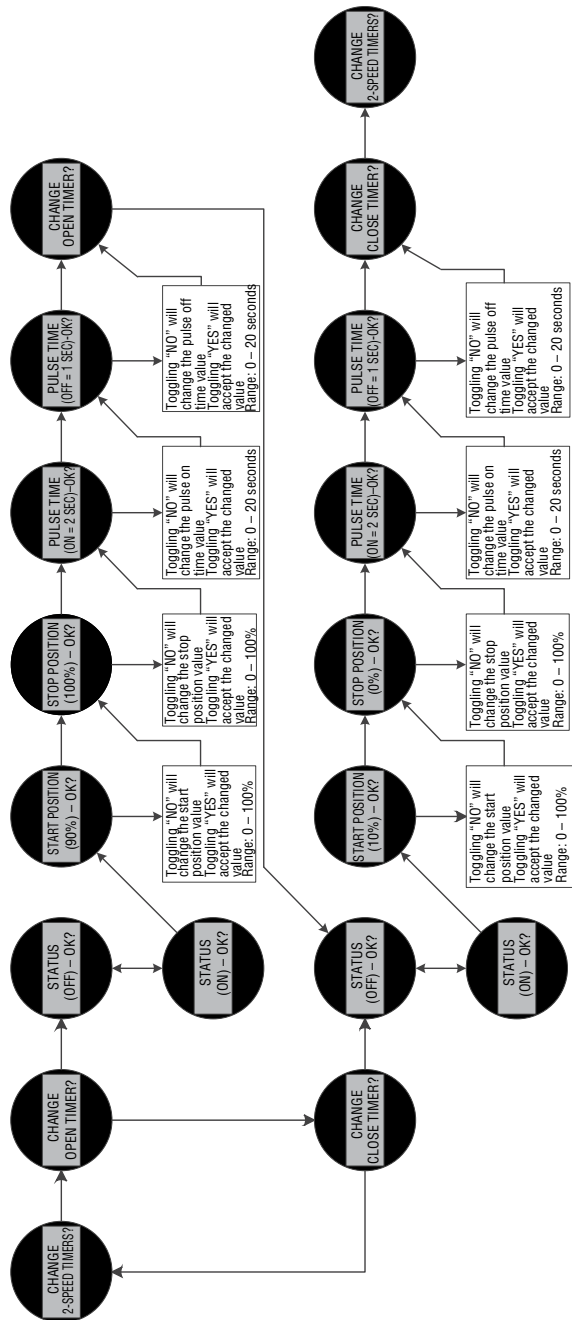

Note: This menu option is available to the user only when the "POSITION INDICATION" option has been ENABLED during the initial actuator setup.

Change Analog Out: Allows the user to configure the Analog Output option to provide positional feedback

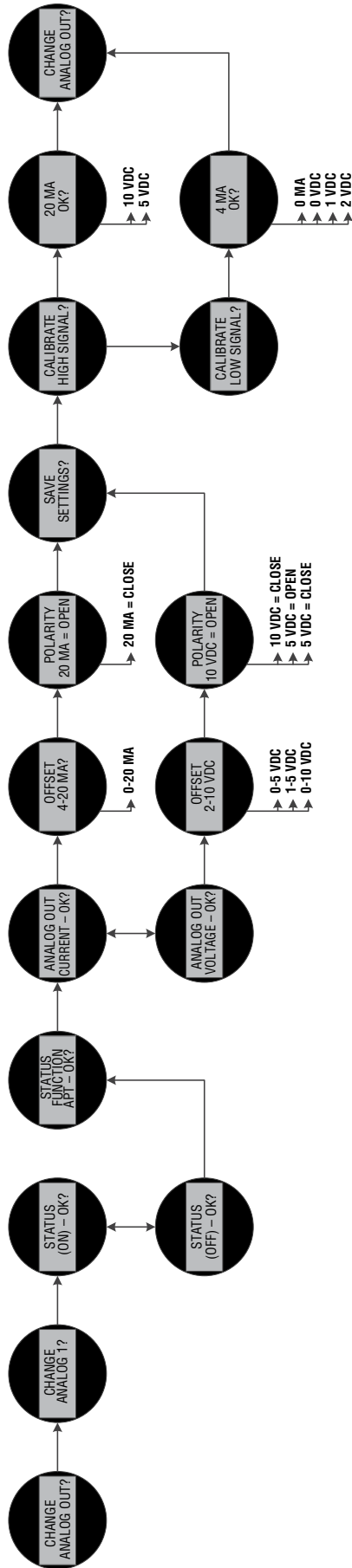

Note: This menu option is available to the user only when the "POSITION INDICATION" option has been ENABLED during the initial actuator setup.

Change Remote: Allows the user to configure the actuator to respond to a certain type of signal

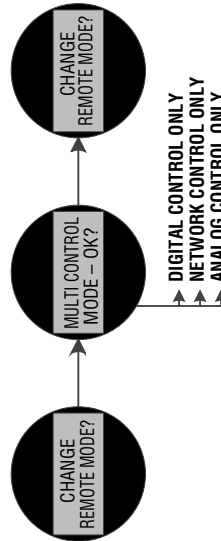

Note: This menu option is available to the user only when the "POSITION INDICATION" option has been ENABLED during the initial actuator setup.

Change Local Control: Allows the user to enable/disable the upfront control knobs, to configure the local operation of the actuator and to configure the red and green LED orientation

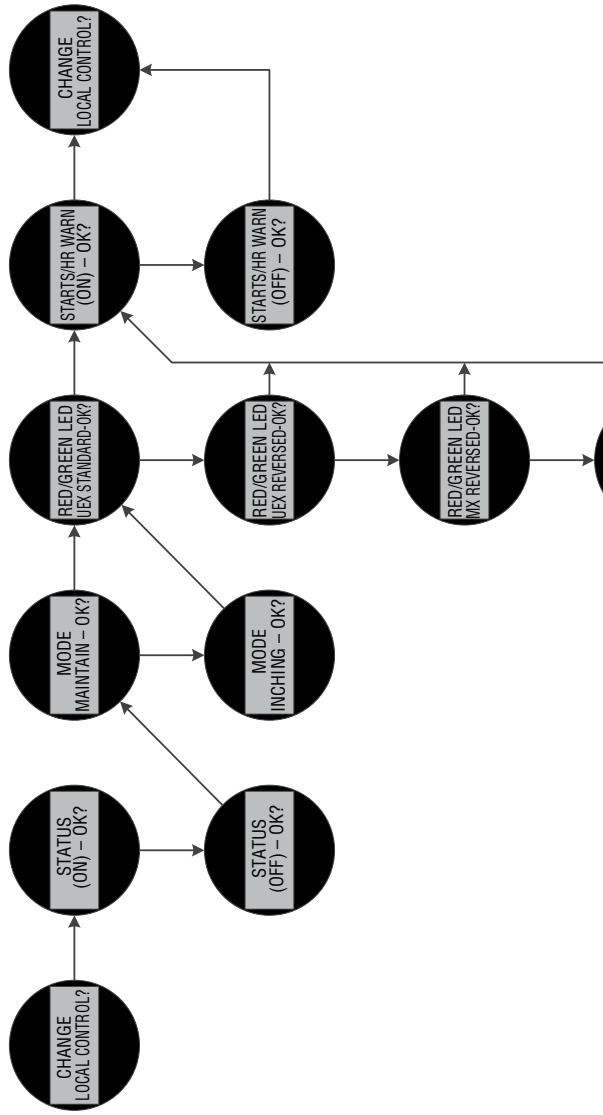

Change ESD Overrides: Allows the user to set ESD priorities

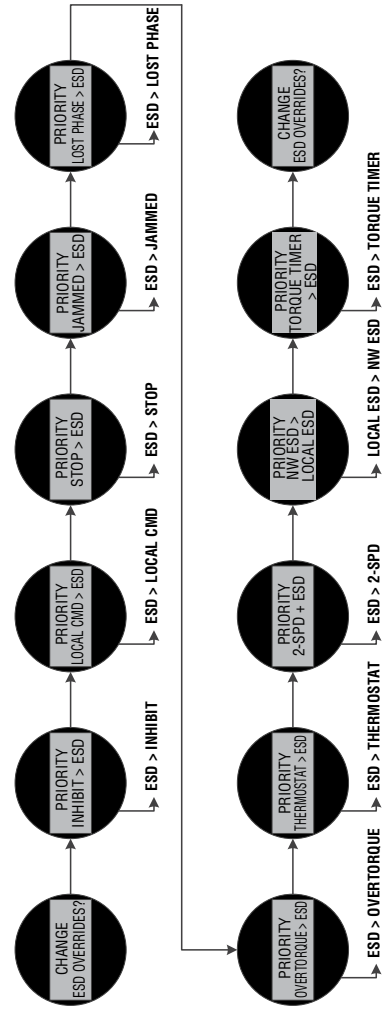

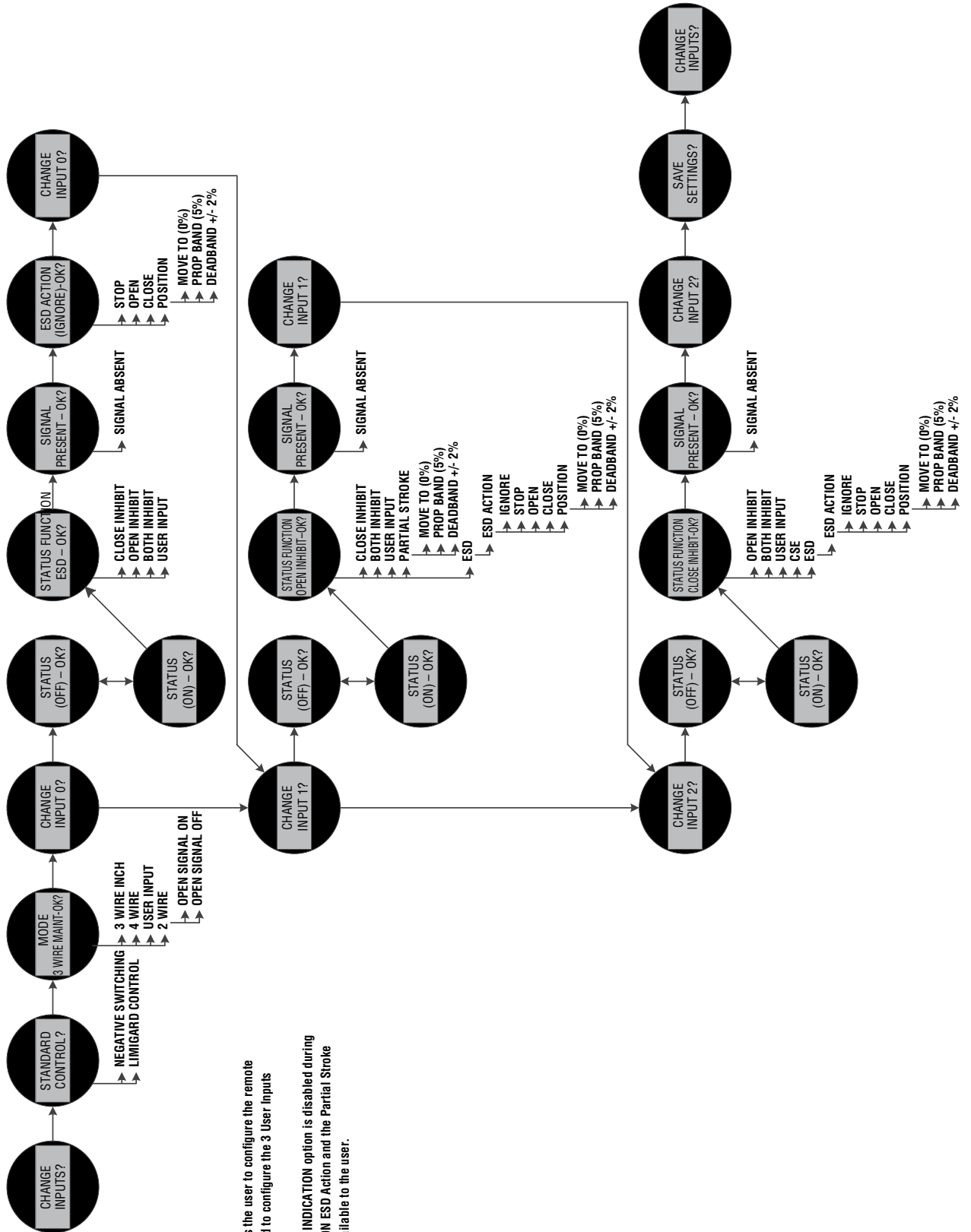

Change Inputs: Allows the user to configure the remote control wiring type and to configure the 3 User Inputs

Note: If the POSITION INDICATION option is disabled during the setup, the POSITION ESD Action and the Partial Stroke options will not be available to the user.

Change Monitor Relay: Allows the user to configure the monitor relay

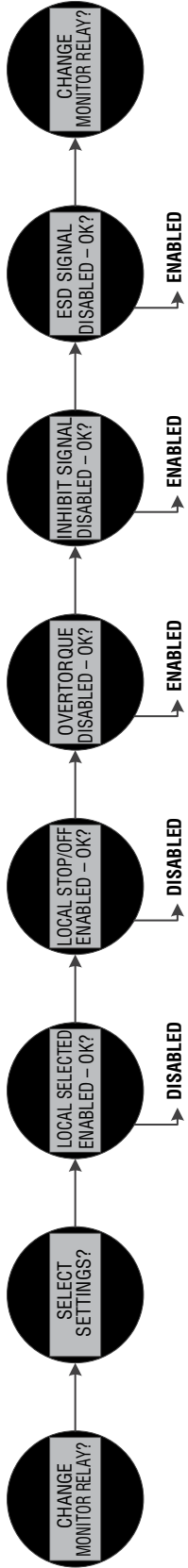

Change Diagnostic Reset: Allows the user to clear the diagnostic and operations counters in the actuator

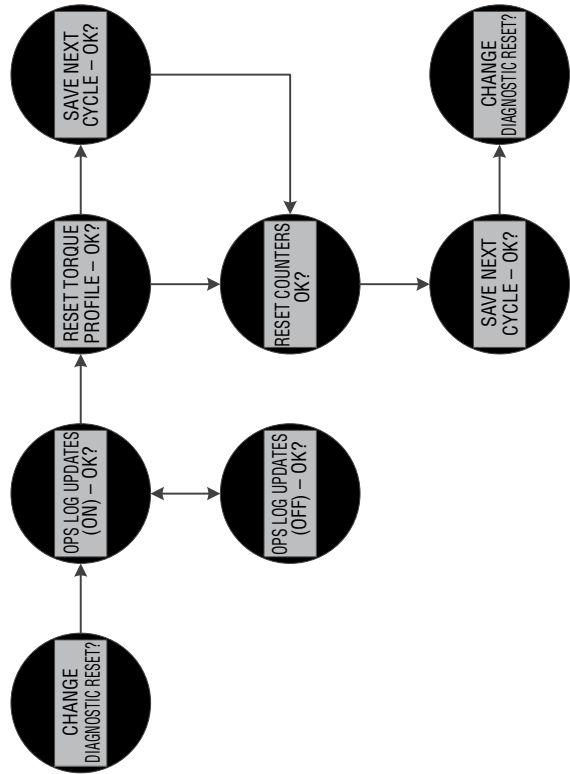

Change Tag: Allows the user to enter the actuator/valve tag information

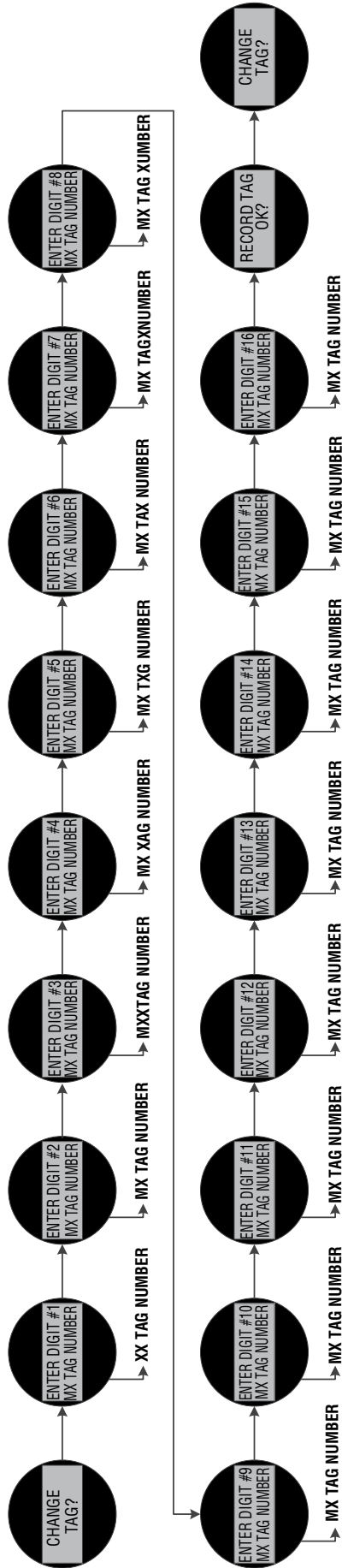

Change LCD Contrast: Allows the user to adjust the display contrast

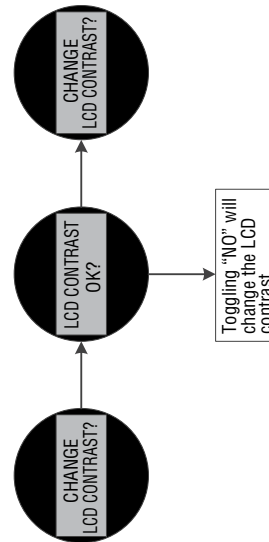

Change Password: Allows the user to change the actuator password

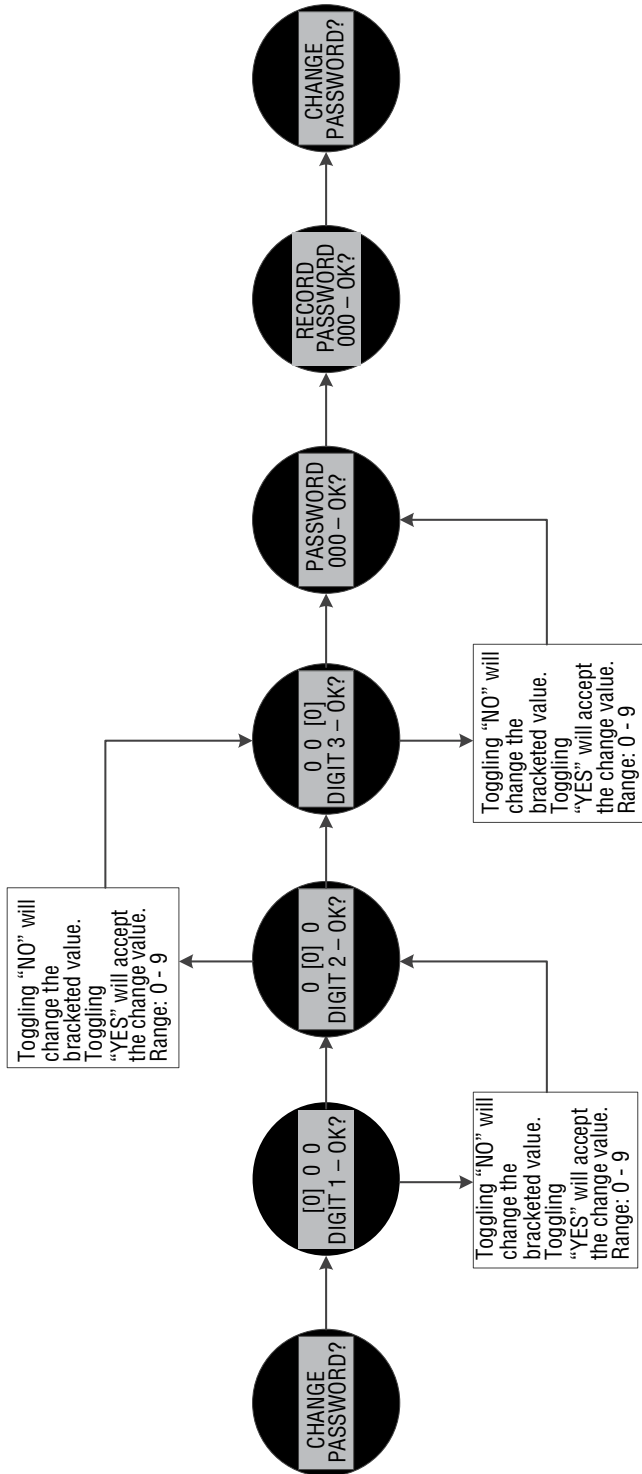

Change Motor Thermostat: Allows the user to enable/disable the motor thermostat

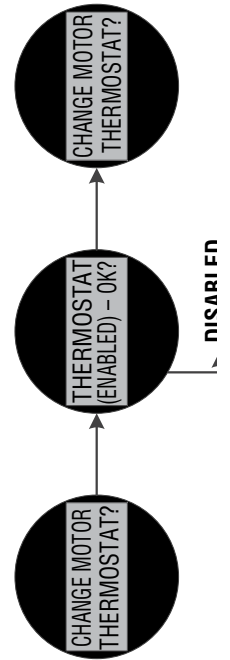

Change Valve Data: Allows the user to enter the valve type, serial number and model number

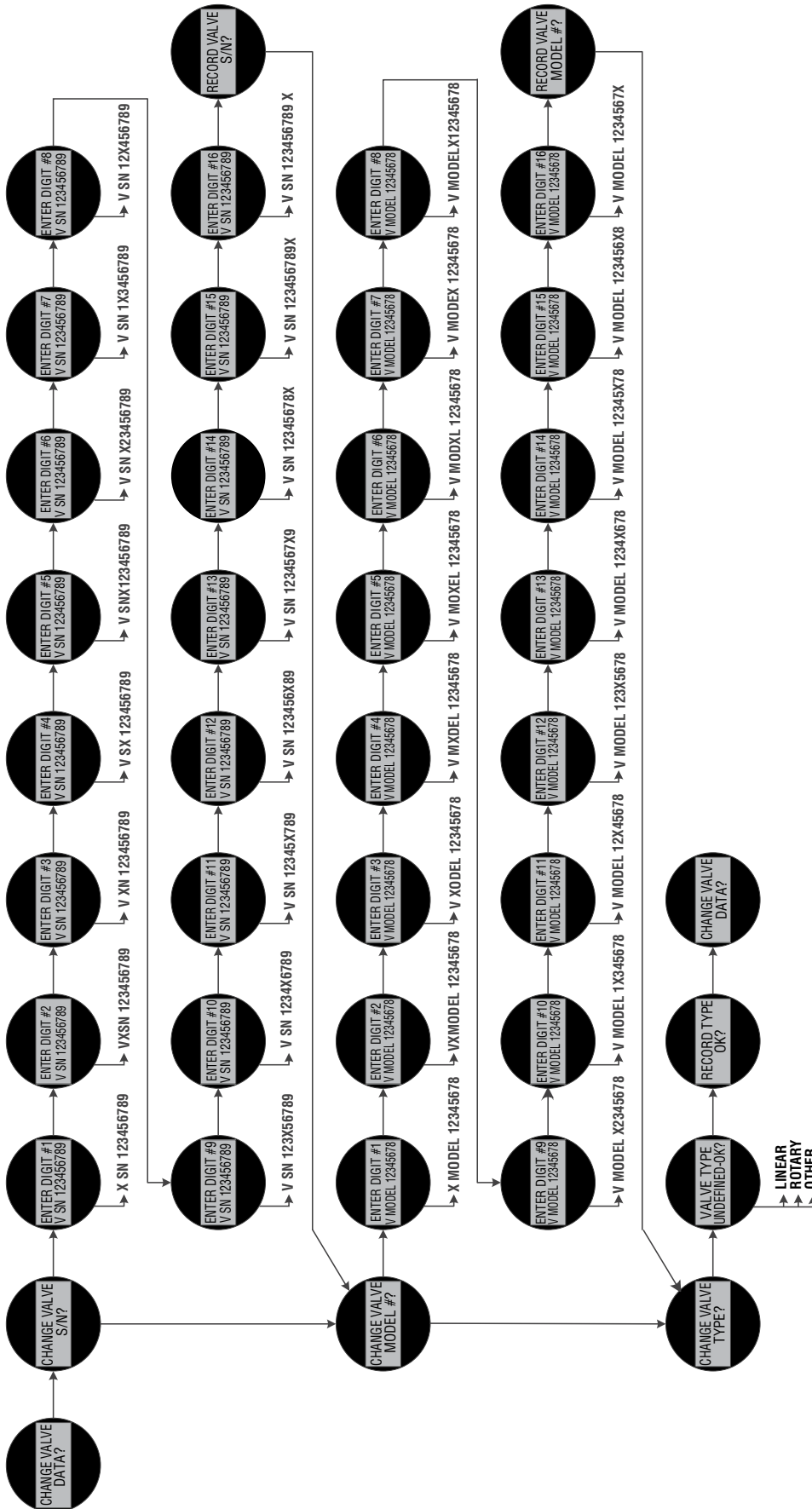

Change Port: Allows the user to enable/disable the actuator communication ports

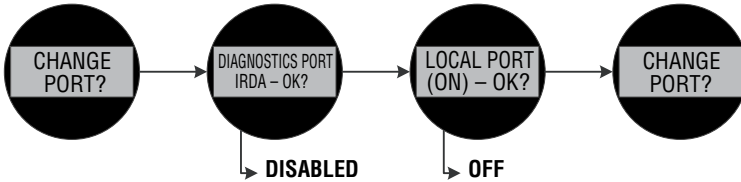

Restricted Setup: Allows the user to enable actuator options and perform certain functions that require a factory supplied keycode

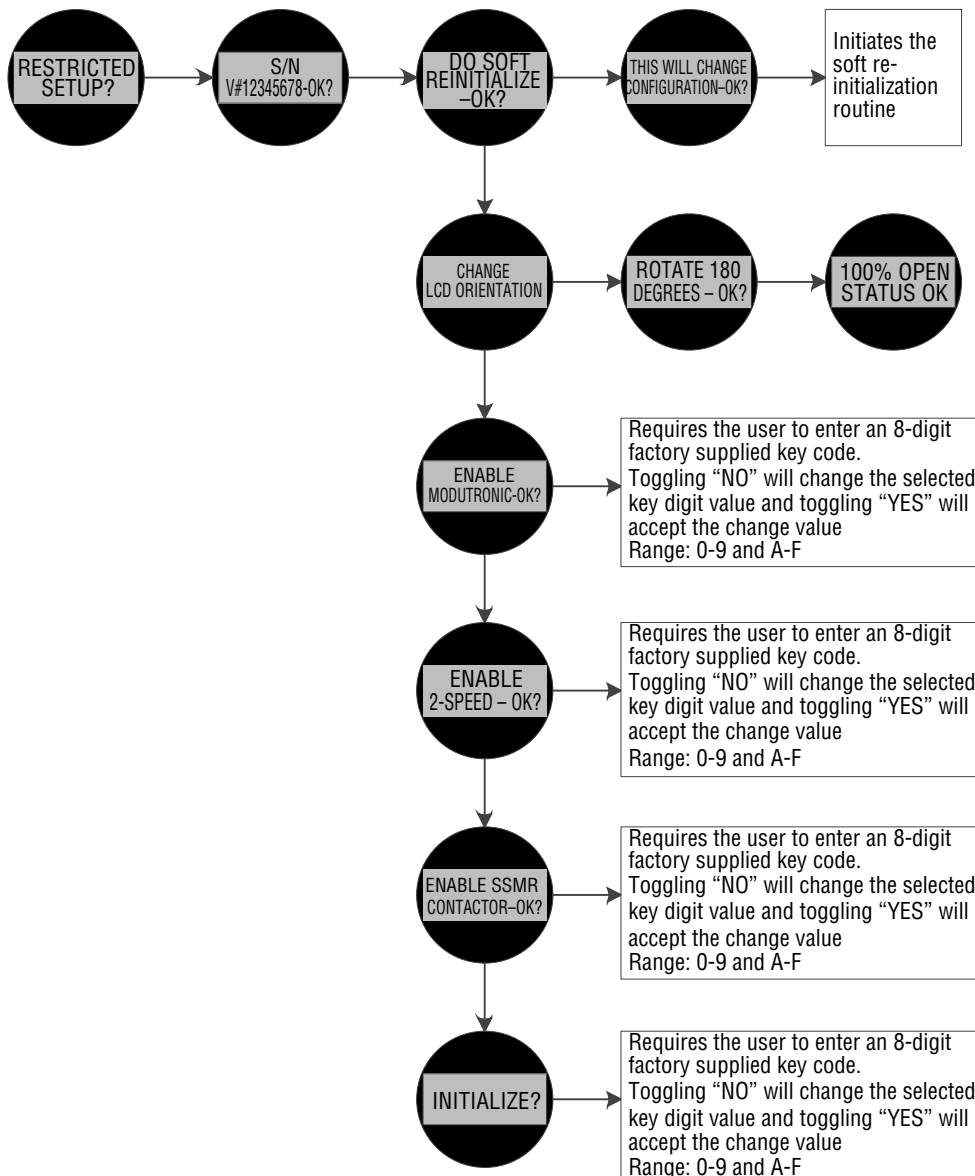

15 UEX Wiring Diagrams

Figure 15.1 – Standard Wiring Diagram for UEX Controllers

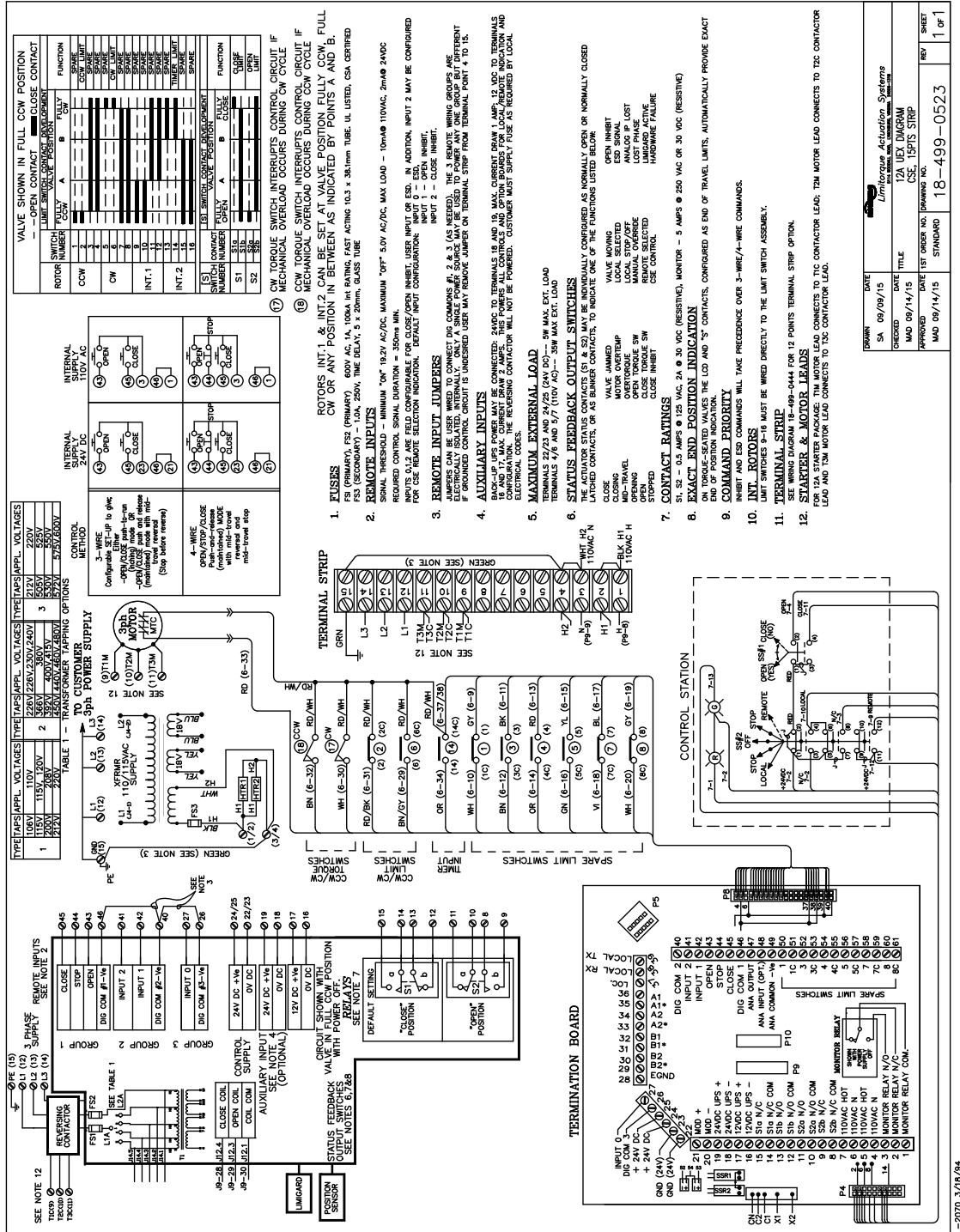

L-2070 3/18/94

Figure 15.2 - DDC Wiring Diagram for UEX Controllers

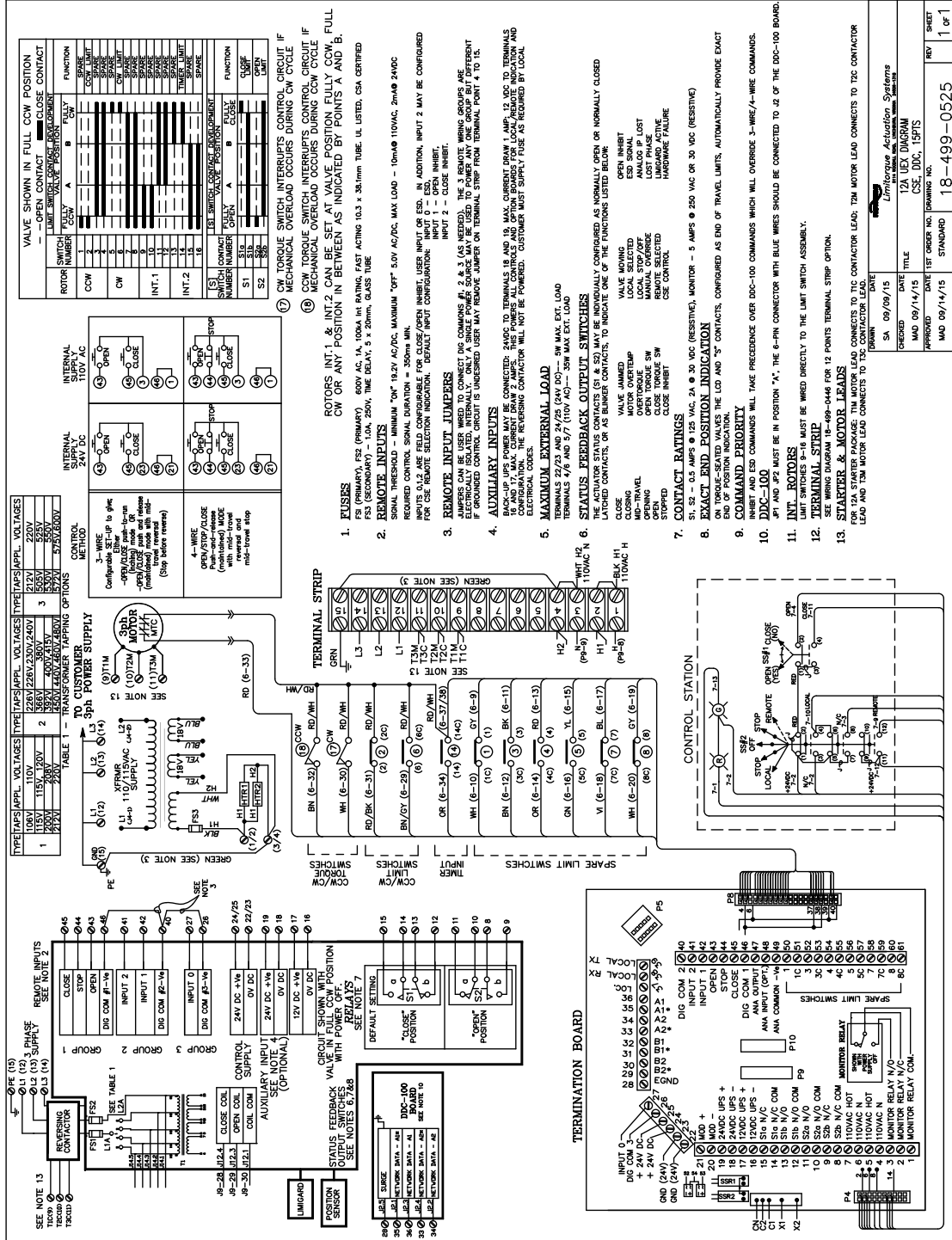

Figure 15.3 - MOD APT Wiring Diagram for UEX Controllers

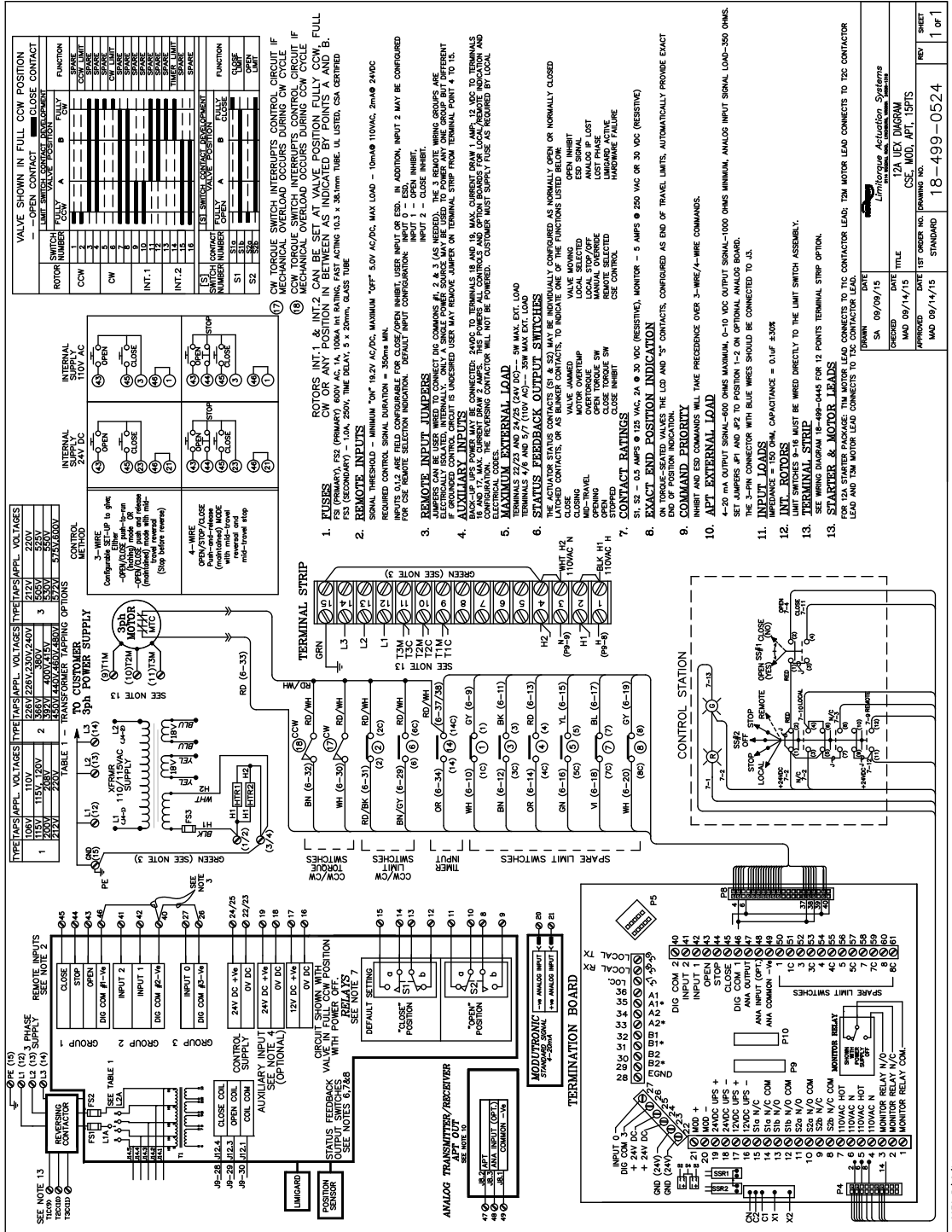
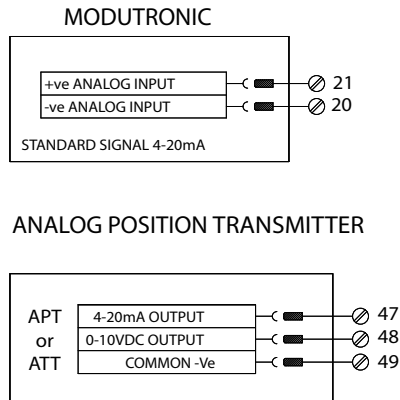

Figure 15.4 – Optional Features Wiring Diagrams



Optional voltages or currents; 0-20 mA, 4-20 mA, 0-10 VDC, 2-10 VDC, 0-5 VDC, 1-5 VDC

EXTERNAL LOAD – APT & ATT

4-20 mA SIGNAL - 470 ohms MAXIMUM for 99.9% accuracy/750 ohms MAXIMUM for 99% accuracy
 0-10 VDC SIGNAL - 2700 ohms MINIMUM for 99% accuracy and 1000 ohms for 99.9% accuracy.

MODUTRONIC

COMMAND SIGNAL = 4-20 mA
 INPUT IMPEDANCE = 150 ohms
 INPUT CAPACITANCE = 0.1 µF ±30%

NOTE:

ACTUATORS SUPPLIED WITH “R” DEVICES ARE SHIPPED WITH DEFAULT SETTINGS AS SHOWN ON THE DIAGRAM, UNLESS OTHERWISE SPECIFIED.

EXACT END POSITION INDICATION

ON TORQUE-SEATED VALVES, THE LCD AND “S” CONTACTS CONFIGURED AS END-OF-TRAVEL LIMITS AUTOMATICALLY PROVIDE EXACT END POSITION INDICATION.

ANALOG INPUT

STANDARD SIGNAL 4-20 mA
 INPUT IMPEDANCE = 350 ohms
 INPUT CAPACITANCE = 0.1 µF ±30%
 99% ACCURACY
 CONFIGURABLE SCALING

INT ROTORS

LIMIT SWITCHES 9-16 MUST BE WIRED DIRECTLY TO THE LIMIT SWITCH ASSEMBLY.

CONNECTIONS

CONNECTION LANDED ON INTERFACE BOARD.

Figure 15.5 – Modbus, FOUNDATION Fieldbus, Profibus DP V1, and Profibus PA, and DeviceNet Network Wiring Diagrams

NOTE: CONNECTIONS LANDED TO INTERFACE BOARD.

Modbus

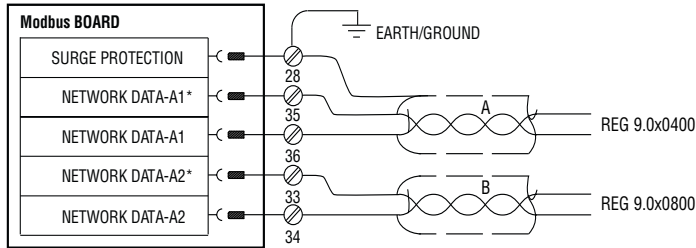

LOSS OF COMMUNICATION ON A1 => REGISTER 9 CHANNEL A (BIT 0x0400) SET TO 1

LOSS OF COMMUNICATION ON A2 => REGISTER 9 CHANNEL B (BIT 0x0800) SET TO 1

PREFERRED NETWORK WIRING IS TO CONNECT ONLY ONE SHIELD TO EARTH/GROUND. REFER TO DDC INSTALLATION DOCUMENTATION.

DDC-100:

JP1 AND JP2 MUST BE IN POSITION "A". THE 6-[IN CONNECTOR WITH BLUE WIRES SHOULD BE CONNECTED TO J2 OF THE DDC-100 BOARD.

FOUNDATION Fieldbus_H1

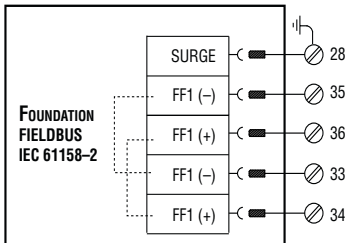

CUSTOMER IS REQUIRED TO CONNECT WIRE BETWEEN TERMINAL 3 AND CHASSIS GROUND FOR SURGE PROTECTION. PREFERRED NETWORK WIRING IS TO CONNECT SEGMENT SHIELD TO EARTH/GROUND AT ONE POINT ONLY. ATTACH SHIELD TO TERMINAL 3 ONLY IF SEGMENT IS NOT GROUNDED. ELSEWHERE, CUSTOMER MUST CONNECT INDIVIDUAL NETWORK CABLE SHIELDS TOGETHER TO ENSURE PROPER SHIELDING OF THE ENTIRE NETWORK.

DeviceNet

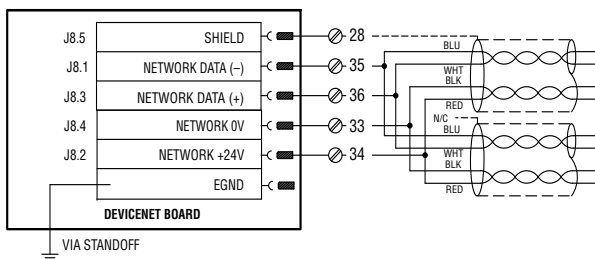

RECOMMENDED DEVICENET CABLE IS BELDEN 3084A OR EQUAL. 120 OHM, 1/4W TERMINATION RESISTORS MUST BE CONNECTED AT EACH SEGMENT END. PREFERRED NETWORK WIRING IS TO CONNECT SHIELD TO TERMINAL 3 FOR EVERY UNIT ON SEGMENT. SHIELD SHOULD BE CONNECTED TO POWER SUPPLY GROUND AT THE CLOSEST POINT IN THE CENTER OF THE NETWORK.

Profibus DP_V1

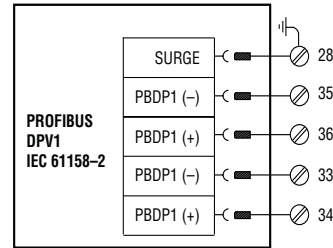

CUSTOMER IS REQUIRED TO CONNECT WIRE BETWEEN TERMINAL 3 AND CHASSIS GROUND FOR SURGE PROTECTION. PREFERRED NETWORK WIRING IS TO CONNECT SHIELD TO EARTH/GROUND AT BOTH ENDS OF THE SEGMENT. ATTACH SHIELD TO TERMINAL 3 ONLY IF DEVICE IS LOCATED AT THE ENDS OF THE SEGMENT. CUSTOMER MUST CONNECT REMAINING INDIVIDUAL NETWORK CABLE SHIELDS TOGETHER TO ENSURE PROPER SHIELDING OF THE ENTIRE NETWORK.

Profibus_PA

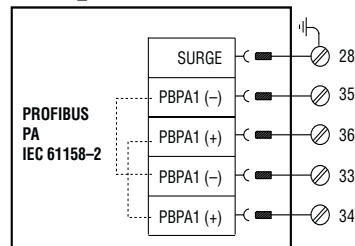

CUSTOMER IS REQUIRED TO CONNECT WIRE BETWEEN TERMINAL 3 AND CHASSIS GROUND FOR SURGE PROTECTION. PREFERRED NETWORK WIRING IS TO CONNECT SEGMENT SHIELD TO EARTH/GROUND AT ONE POINT ONLY. ATTACH SHIELD TO TERMINAL 3 ONLY IF SEGMENT IS NOT GROUNDED. ELSEWHERE, CUSTOMER MUST CONNECT INDIVIDUAL NETWORK CABLE SHIELDS TOGETHER TO ENSURE PROPER SHIELDING OF THE ENTIRE NETWORK.

NOTES:

TERMINALS 13 & 14 FOR FOUNDATION FIELDBUS, PROFIBUS PA, PROFIBUS DP_V1 ARE USED FOR CHANNEL B ON OPTIONAL REDUNDANT NETWORK BOARD.

16 Network Protocol Connections

16.1 Network Wiring – Modbus

Please consult LMENIM2329 for detailed installation instructions.

- Belden 3105A Specifications

Total cable length between repeaters or nodes with repeaters:

- @ 9.6 kbps: 11500 ft. (3.5 km)
- @ 19.2 kbps: 5750 ft. (1.7 km)

Key Specifications

- Resistance/1000 ft = 22 AWG (7 x 30) 14.7 ohms each conductor (29.4 ohms for the pair)
- Capacitance/ft. = 11.0 pF (conductor-to-conductor)
- Capacitance/ft. = 20.0 pF (conductor-to-shield)

- Belden 3074F specifications

Total cable length between repeaters or nodes with repeaters:

- @ 9.6 kbps: 15000 ft. (4.5 km)
- @ 19.2 kbps: 7500 ft. (2.2 km)

Key Specifications

- Resistance/1000 ft = 18 AWG (7x26) 6.92 ohms each conductor (13.84 ohms for the pair)
- Capacitance/ft. = 14 pF (conductor-to-conductor)
- Capacitance/ft. = 14 pF (conductor-to-shield)

- Belden 9841 specifications

Total cable length between repeaters or nodes with repeaters:

- @ 9.6 kbps: 6560 ft (2 km)
- @ 19.2 kbps: 3300 ft. (1 km)

Key Specifications

- Resistance/1000 ft = 24 AWG (7 x 32)
24 ohms each conductor (48 ohms for the pair)
- Capacitance/ft. = 12.8 pF (conductor-to-conductor)
- Capacitance/ft. = 23 pF (conductor-to-shield)

Figure 16.1 – Typical Modbus Network Wiring Diagrams – Single Loop

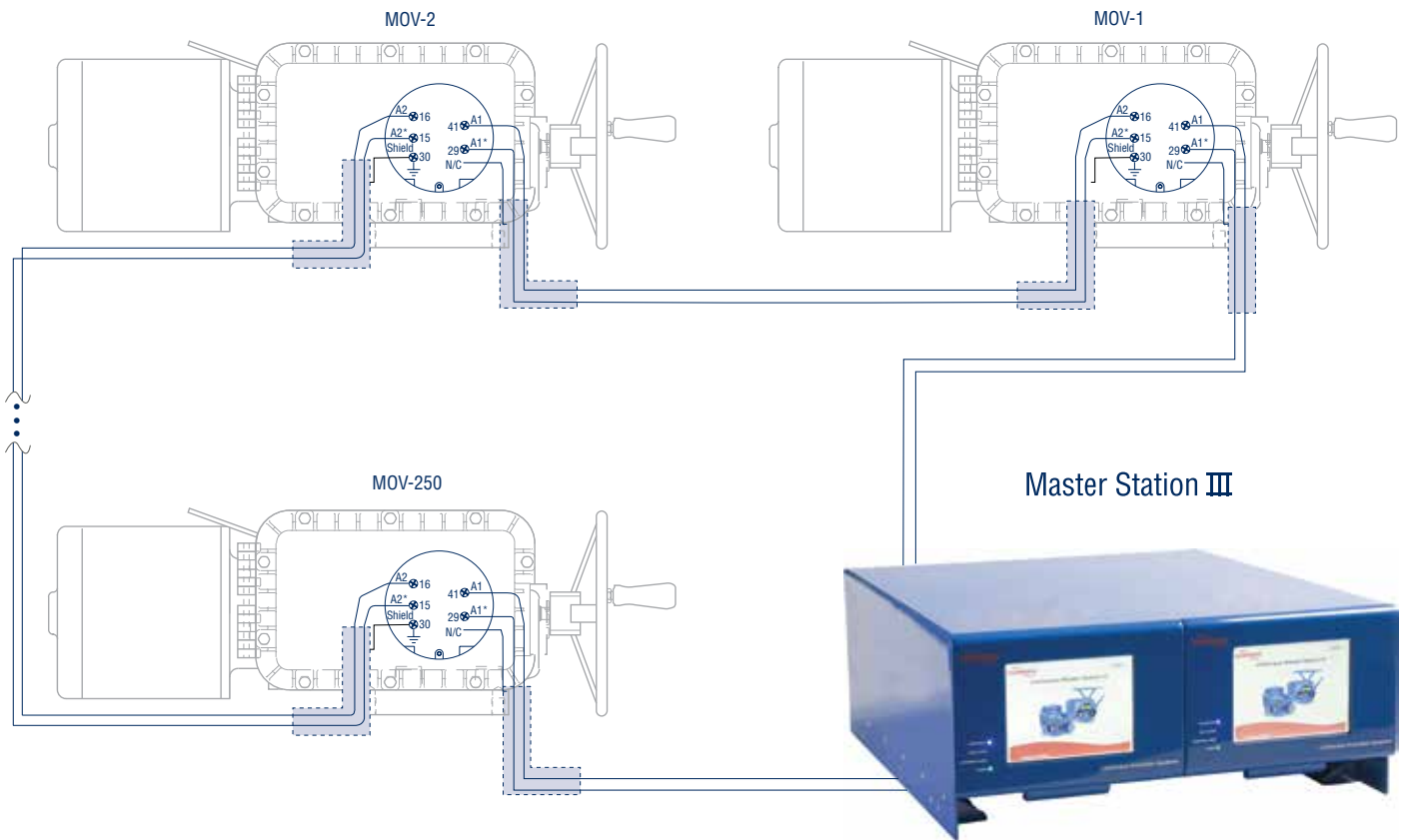

Legend:

- MOV - Motor Operated Valve
- A1 -Data Channel 1
- A1*-Data Channel 1*
- A2 -Data Channel 2
- A2*-Data Channel 2*
- N/C-No Connection-Shielded cable

Notes:

- Correct polarity for field unit and master station connections is necessary for proper operation.
- The connections shown are typical. The number of MOVs will vary up to a maximum of 250.
- The ground connection should be a ground rod or ground grid.

16.2 Network Wiring – Foundation Fieldbus H1

Please refer to LMENIM2330 for detailed installation instructions.

Limitorque's FOUNDATION Fieldbus field unit conforms to open Fieldbus standard IEC 61158. It is suitable for use on the H1 highway and uses a twisted-pair cable for connection to the highway.

The UEX FF field unit fits in the actuator in the sealed electrical housing. All adjustments to the UEX FF settings may be made over the FOUNDATION Fieldbus data highway using a network configuration tool.

The UEX FF unit may command its actuator to open, stop, close, move to a set position, or perform an emergency shutdown operation. Commands to the unit come over the network from the host system, which may be a PC, Distributed Control System (DCS), Programmable Logic Controller (PLC), or some other microprocessor-based device. Commands may also be generated in another network actuator or device and transmitted over fieldbus using peer-to-peer, publisher/subscriber communication.

A fieldbus device is an intelligent device within the actuator that can send multiple variables to the control system over a high-resolution and distortion-free digital communication network. The device provides control and self-test capabilities, which allow abnormal conditions to be easily and immediately identified before an unplanned shutdown.

Additional features and benefits are:

- Reduces cost of wiring and installation – existing wiring and multi-drop connections can be used.
- Interoperable devices – devices from different suppliers can communicate with one another on the same network.

A typical UEX FF system is shown in Figure 16.2.

Figure 16.2 – Typical FOUNDATION Fieldbus System with a DCS Host (Daisy Chain Shown)

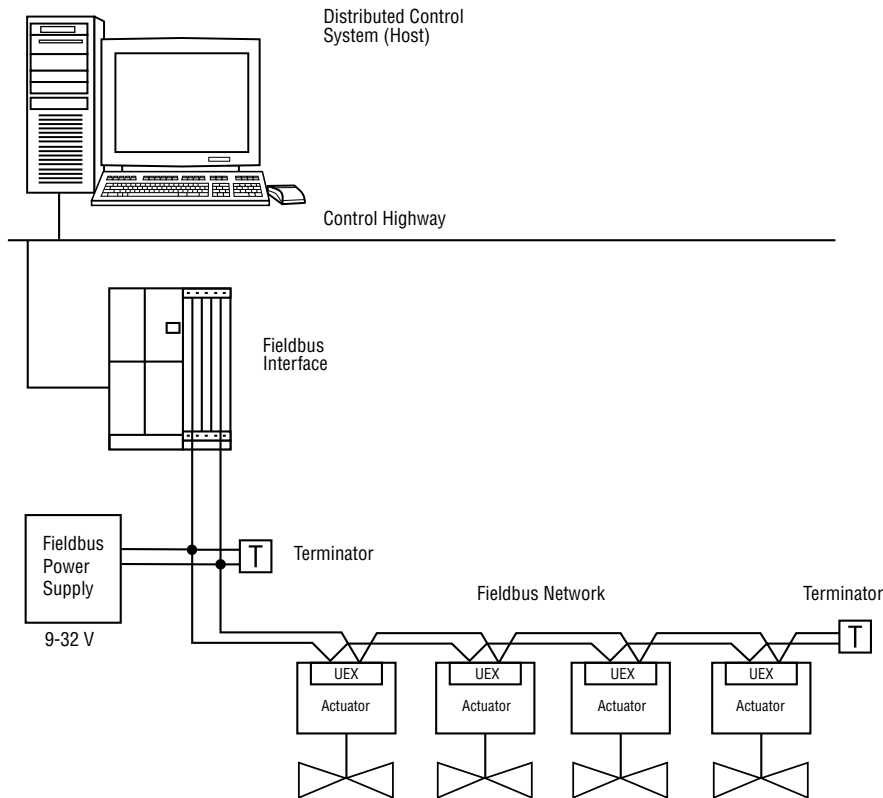

For fieldbus technology and cabling information, refer to the following documents:

- Foundation Fieldbus Wiring and Installation 31.25 kbits/s, Voltage Mode, Wire Medium AG-140
- Foundation Fieldbus Technical Overview, FD-043
- Relcom Inc. Fieldbus Wiring Design and Installation Guide
- ANSI/ISA-S50.02, Part 2-1992, Fieldbus Standard for Use in Industrial Control Systems Part 2: Physical Layer Specification and Service Definition
- Foundation Fieldbus FF-890 and FF-891, Foundation Specification, Function Block Application Process, Part 1 and 2.

Reference can be made to the following books:

- *Fieldbuses for Process Control: Engineering, Operation, and Maintenance*. ISBN 1-55617-760-7.

Network Wiring – FOUNDATION Fieldbus

- Belden 3076F Specifications
Key Specifications – 18 AWG
 - Nominal Capacitance 80 pF/m
 - Nominal DC Resistance 24 ohm/km max
 - Characteristic Impedance 100 ohms
 - Nominal Impedance – 100.0

16.3 Network Wiring – Profibus DP and PA

Please refer to LMENIM2336 for detailed installation instructions.

Profibus is based on RS 485 communication. The standard EN 50170 specifies the cable for use with Profibus DP and PA. Table 16.1 shows specifications that need to be fulfilled by the Profibus cable.

Table 16.1 – Specifications for the Profibus Cable

Parameter	Type – Profibus DP
Impedance	135 to 165 ohm/3 to 20 MHz
Capacity	< 30 pF/m
Resistance	< 110 ohm/km
Wire gauge	> 0.64 mm
Conductor area	> 0.34 mm ²

The Profibus DP cable is a shielded twisted pair cable.

In general, there are two different types of cables available. The most commonly used cable has solid wire for the Profibus line.

When there is a need for more flexibility (bending) and higher environmental resistance, a cable with stranded wire for the Profibus line and special jackets shall be used.

Limitorque recommends the use of:

- Belden 3079A Specifications, 22 AWG, shielded, solid two conductor

Key Specifications

- Capacitance/ft = 8.5 pF
- Nominal Impedance (ohms) – 150.0

Network Wiring – Profibus PA – Belden 3076F

Please refer to IEC 61158 and ANSI/ISA S.50.02 Part 2-1992 for network wiring guidelines.

Maximum number of devices on a segment = 32 (including repeaters)

Table 16.2 – Maximum Segment Length

Data transfer rate in kbit/s	9.6	19.2	45.45	93.75	187.5	500	1500	3000	6000	12000
Maximum segment length in m	1200	1200	1200	1200	1000	400	200	100	100	100

Figure 16.3 – Typical Profibus System with a DCS Host (Daisy Chain Shown)

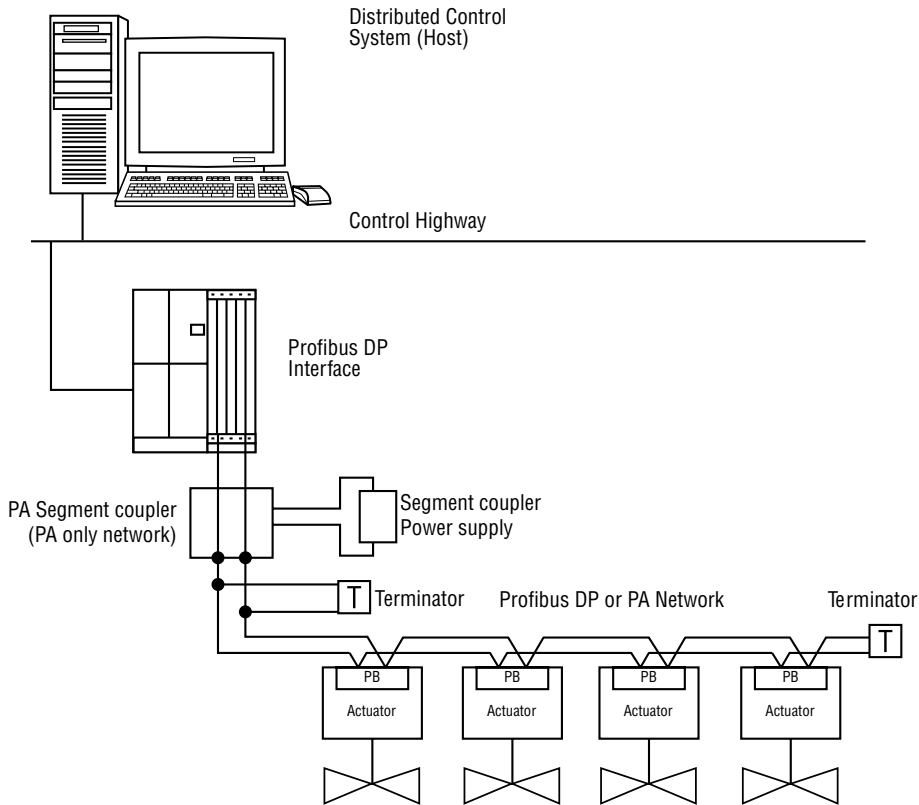

16.4 Network Wiring – DeviceNet

Please refer to LMENIM2328 for detailed installation instructions.

DeviceNet is a CAN - based protocol that uses 5 wires including a shield. Two of the conductors are used for 24V DC power & up to 8 amps (4 amps for NEC Class 2) may be passed along the hi-way from a suitable power source. Two conductors are used for the CAN bus signals, CAN_H and CAN_L, which are usually smaller in diameter. Limitorque recommends Belden cable for connecting to a DeviceNet network. The specifications for thick and thin cable (per site requirements) are as follows:

Table 16.3 – Belden Cable Specifications

Belden Part No.	AWG (Stranding) dia. Inches Nom. DGR	Insulation material (color code)	Nominal O.D.	Nom Impedance (ohms)	Nominal Capacitance	Test Frequency (MHz)	Maximum Attenuation dB/100ft
3082A	2 – 15 AWG (19 x 28) 3.6 ohm/1000 ft 11.8 ohm/km	Power pair (Black/Red)	12.2 mm	120	12.0 pF/ft	0.125 0.5 1	0.13 0.25 1.36
	2 – 18 AWG (19 x 30) 6.9 ohm/1000 ft 22.7 ohm/km	Data pair (Blue/White)					
3084A	2 – 22 AWG (19 x 34) 17.5 ohm/1000 ft 57.4 ohm/km	Power pair (Black/Red)	7.2 mm	120	12.0 pF/ft	0.125 0.5 1	0.29 0.50 1.70
	2 – 18 AWG (19 x 36) 28.0 ohm/1000 ft 91.9 ohm/km	Data pair (Blue/White)					

Table 16.4 – Total Cable Length Between Repeaters or Nodes:

Network Size	125 KBPS	250 KBPS	500 KBPS
Thick Trunk Length	500 m (1,640 ft)	250 m (1,640 ft)	100 m (1,640 ft)
Thin Trunk Length	100 m (328 ft)	100 m (328 ft)	100 m (328 ft)
Flat Trunk Length	380 m (1,250 ft)	200 m (656 ft)	75 m (246 ft)
Maximum Drop Length	6 m (20 ft)	6 m (20 ft)	6 m (20 ft)
Cumulative Drop Length	156 m (512 ft)	78 m (256 ft)	39 m (128 ft)

Note: Each actuator includes 0.60 meters of internal drop length.

17

How to Order Parts

To order parts or obtain further information about your Limitorque L120 valve actuators, contact your local Limitorque distributor sales office, or:

Flowserve Limitorque

5114 Woodall Road
P.O. Box 11318
Lynchburg, VA 24506-1318
Telephone (434) 528-4400
Fax (434) 845-9736

All inquiries or orders must be accompanied by the following information:

1. Actuator Size
2. Limitorque Order Number
3. Limitorque Serial Number

18 Regulatory Information

Application of Council Directives

2004/108/EC; EMC Directive
2006/42/EC; Machinery Directive
2003/10/EC; Airborne Noise Directive

Standards to which Conformity is Declared

Machinery; EN 60204-1
EMC; Emissions; EN 55022; 2006
Immunity; IEC 61000-4-6; 2007, IEC 61000-4-8: 2001
ESD; IEC 61000-4-2: 2001
EFT Bursts; IEC 61000-4-4: 2004
Surge Immunity; IEC 61000-4-5: 2006
Airborne Noise; MIL-STD-740-1, Table 1, EN 60204

Manufacturer's Name

Flowserve-Limitorque

Manufacturer's Address

5114 Woodall Rd
Lynchburg, VA 24502 USA

Importer's Name

Flowserve-Limitorque

Importer's Address

Euro House, Abex Road, Newbury, Berkshire, RG14 5EY England

Type and Description of Equipment

Valve Actuators

Model Numbers

L120-10,20,40, 85

Note: Tested with Limitorque products only and with standards applicable at the time of testing.

I, the undersigned, hereby declare that the equipment specified above conforms to the above-listed Standards and Directives.



John Thilking
Senior Engineer-Certifications, ATEX/IEC-Ex Authorized Person
Flowserve-Limitorque
5114 Woodall Rd
Lynchburg, VA 24502 USA

Date; December 4, 2012



Flowserve Corporation

United States

Flowserve Limatorque
5114 Woodall Road
P.O. Box 11318
Lynchburg, VA 24506-1318
Phone: 434-528-4400
Fax: 434-845-9736

England

Flowserve Limatorque
Euro House
Abex Road
Newbury
Berkshire, RG14 5EY
United Kingdom
Phone: 44-1-635-46999
Fax: 44-1-635-36034

Singapore

Limatorque Asia, Pte., Ltd.
12, Tuas Avenue 20
Singapore 638824
Phone: 65-6868-4628
Fax: 65-6862-4940

China

Limatorque Beijing, Pte., Ltd.
RM A1/A2
22/F, East Area, Hanwei Plaza
No. 7 Guanghua Road, Chaoyang
District
Beijing 100004, Peoples Republic
of
China
Phone: 86-10-5921-0606
Fax: 86-10-6561-2702

India

Flowserve Limatorque
Plot No. #4, 1 A, Road No. 8,
EPIP
Whitefield, Bangalore – 560066
Karnataka
India
Phone: 91-80-40146200
Fax: 91-80-28410286

Italy

Flowserve Limatorque
Fluid Power Systems
Via Rio Vallone 17
20883 Mezzago MB
Italy
Phone: 39-039-620601
Fax: 39-039-62060 213

FCD LMENIM1205-04-A4 Printed in USA. November 2015

To find your local Flowserve Limatorque representative
visit www.limatorque.com or call 1 434 528 4400

Flowserve Corporation has established industry leadership in the design and manufacture of its products. When properly selected, this Flowserve product is designed to perform its intended function safely during its useful life. However, the purchaser or user of Flowserve products should be aware that Flowserve products might be used in numerous applications under a wide variety of industrial service conditions. Although Flowserve can (and often does) provide general guidelines, it cannot provide specific data and warnings for all possible applications. The purchaser/user must therefore assume the ultimate responsibility for the proper sizing and selection, installation, operation, and maintenance of Flowserve products. The purchaser/user should read and understand the Installation Operation Maintenance (IOM) instructions included with the product, and train its employees and contractors in the safe use of Flowserve products in connection with the specific application.

While the information and specifications contained in this literature are believed to be accurate, they are supplied for informative purposes only and should not be considered certified or as a guarantee of satisfactory results by reliance thereon. Nothing contained herein is to be construed as a warranty or guarantee, express or implied, regarding any matter with respect to this product. Because Flowserve is continually improving and upgrading its product design, the specifications, dimensions and information contained herein are subject to change without notice. Should any question arise concerning these provisions, the purchaser/user should contact Flowserve Corporation at any one of its worldwide operations or offices.

© 2015 Flowserve Corporation, Irving, Texas, USA. Flowserve is a registered trademark of Flowserve Corporation.